

H.M.S. 'INVINCIBLE'

## MARINE GAS TURBINE EXPERIENCE IN THE FALKLANDS WAR

BY

COMMANDER P. W. W. RIDLEY, B.SC.(ENG)., C.ENG., M.I.MECH.E., R.N.  
(Sea Systems Controllerate)

*This article was written late in 1982 and therefore does not incorporate the latest information now available from subsequent engine examinations. It is published as a direct report of gas turbine experience under war conditions. It was the subject of a paper presented by the author at the Conference on 'Naval Engineering—Present and Future' held at the University of Bath in September 1983 to mark the centenary of the Royal Corps of Naval Constructors and is printed by courtesy of the Institution of Mechanical Engineers.*

### Introduction

In August 1982 the author wrote a paper<sup>1</sup> on the Falklands experience for the American Society of Mechanical Engineers, read at the 28th Gas Turbine Conference in March 1983, and much of the present paper is based on that earlier one. During the three intervening months, however, reports and data from returning ships have been analysed in greater depth, and some refinement of the first impressions included in the ASME paper has been possible. Nevertheless, its overall conclusion has been upheld beyond any doubt—that in the South Atlantic in 1982, in company with the men and ships of the Royal Navy, Rolls-Royce Marine gas turbines won their spurs.

By the end of October a total of 51 R.N. warships had been involved in the Falklands operation. The Task Force that first sailed at the beginning of April was smaller, of course, and of the 32 warships that actually fought during the campaign, 19 were driven solely by aero-derived marine gas

turbines. TABLE I shows statistics for reported defects and engine hours for three periods—for the year up to the start of Corporate (as the operation to re-occupy the Falkland Islands was called); the period between April and June 1982 during which the campaign itself was fought; and finally for the entire 6 month period after the Task Group sailed.

TABLE I—*Reported Defects and Engine Hours—All R.N. COGOG and COGAG Ships (not just those in the South Atlantic)*

Columns	Year Ending March 1982			April to June 1982			April to Sept 1982		
	1	2	3	4	5	6	7	8	9
Engine Type	Hours Accumulated	Reported Defects	Defects per 1000 Hours	Hours Accumulated	Reported Defects	Defects per 1000 Hours	Hours accumulated	Reported Defects	Defects per 1000 Hours
Olympus TM3B (21 MW)	21 579	53	2.46	20 128	14	0.69	36 155	30	0.82
Tyne RM1A (3.3 MW)	42 028	50	1.19	21 597	9	0.42	26 128	23	0.88
Tyne RM1C (4 MW)	12 982	22	1.69	10 034	8	0.79	22 386	23	1.03
TOTAL	76 589	125	1.63	51 179	31	0.60	84 669	76	0.89

Note: Statistics are for *all* reported defects; the majority were repaired by ship's staff in a matter of hours

The 51,759 hours accumulated on aero-derived gas turbines between April and June represent an increase of approximately two and a half times the number of hours that might have been expected in a similar period in peacetime. Comparison of columns 3, 6 and 9 show the extent that the number of defects actually reported reduced for the period of the war itself. Of course, under these circumstances it was natural for Marine Engineering Officers to indulge in greater self-help by attempting to solve problems more quickly by themselves and thus make it unnecessary to report a defective engine. At the same time it would have been essential that the Task Group Commander should know precisely the operational availability of each of his ships at all times. Whatever the truth of the picture shown by the statistics, the fact remains that, despite the increase in hours and the heightened usage in terms of power and power changes, throughout the period the availability of ship propulsion was excellent, and no ship was withdrawn at any stage as the result of a defective main propulsion system.

Some information has had to be withheld for reasons of security, but where circumstances permit this paper concentrates on the particular (and entirely new) experience of operating gas turbines in a climatically and militarily hostile environment, 8000 miles from base.

### **Climatic Effects**

Surprisingly there were few problems due to adverse weather, even under the Antarctic winter conditions of the 3-month period from July to September.

#### *Icing*

Icing of air intakes was experienced only infrequently and, on the rare occasions that it did occur, the ice was soft and easily removed by brushing.

All R.N. gas turbine ships have ducting systems that allow intake filters to be bypassed. In the present generation of ships the bypass doors are

spring-loaded and open automatically on high intake depression. As far as can be determined none of these opened in anger at any stage, although it is suspected that some doors may have come off their seatings during violent ship movements in rough weather at high powers or after nearby explosions.

### *Salt Water Ingestion*

The limit for the salt content of intake air to R.N. gas turbines is 0.01 ppm by weight, and in rough weather the continuing integrity of the filtration system is vital if this is to be achieved. In recent months there has been a great deal of discussion over whether the advantages of automatic operation of bypass doors are worth the risk of inadvertent leakage of salt-laden air into the engine, and it has been concluded that the next generation of R.N. ships should have manually-operated doors. Remote operation of the doors may well prove necessary if the area adjacent to the doors is found to be inaccessible in rough weather; this will be decided after model tests or perhaps arctic trials in the first of the new class. Steps are also being taken to lock positively the automatic doors in existing ships.

At first it was thought that salt was reaching the engines via the intake air, particularly in frigates and destroyers with their intakes facing outboard and relatively close to the water line<sup>1</sup>. Certainly conditions were arduous with a heavy concentration of salt water in the atmosphere as spray and aerosol were whipped up by the high winds. Often intakes were directly splashed by waves as ships rolled heavily, and after a time filters became encrusted with salt, a problem exacerbated by the difficulty of getting on to the upper deck for routine maintenance. (In H.M.S. *Invincible*, with her intakes 4 decks above the waterline, filters never had to be cleaned.) Furthermore many ships spent long periods stopped or at very low speeds, often when on the 21 megawatt Olympus engines. Under these circumstances the filters were being asked to work with unusually low air velocities, when they are at their least efficient.

However it is now thought that salt contamination of air reaching the engine was not as widespread as had first been believed. Inspection of intake ducts in ships returned from the South Atlantic has not revealed any extensive streaking with rust or other signs of seawater breakthrough. Further downstream, compressors on engines inspected during subsequent refurbishment have been found to be in good condition, though it is possible that this is merely the result of the regular and efficient washing routines described below.

### **Fuel**

One area where it had been expected that cold weather would have had a marked effect was with the fuel, where it was imagined that waxing would be a particular problem. In practice the temperature was neither low enough nor the cloud point of the diesel oil (F-76) supplied high enough for waxing to manifest itself. However the need for high fuel quality was brought home in a number of other ways.

Excessive micro-biological growth was not a problem, there being a high rate of turnover of fuel, but dirt and sludge were frequently experienced as tanks were run unusually low and rough weather disturbed any sediment present.

During the period of the war a new and unexpected problem occurred with diesel oil, which on occasions was found to contain ultra-fine organic particulate matter deposited from the fuel itself, and of a similar density. It is believed that this degradation had occurred during storage, either ashore or afloat, but the timescale in which this happens has yet to be established.

This dirt passed through all but the finest of filters and it neither settled nor could be centrifuged out in an acceptable time. The appearance of the fuel was cloudy, as it might have been with micro-biological contamination. At first it was thought that the problem might have arisen from using marine gas oils from a commercial rather than an R.N. source, which might have contained more cracked products. However recent work at the Oils Laboratory at the Royal Aircraft Establishment at Cobham has shown that the fine dirt can exist to some extent in fuel from virtually any source.

The Defence Standard for F-76<sup>2</sup> describes a 'Water Reaction Test' in which a measured quantity of fuel is shaken with deionized or distilled water and the extent of separation after 10 minutes recorded. In the past such a test has been found to screen out the worst cases of particulate contamination, but in these latest circumstances it was not always successful.

When analysis of this problem was first attempted, the large number of uncoordinated reports from sea resulted in a number of red herrings being energetically pursued. The operational situation at the time obviously precluded proper investigation of the phenomenon and it is only now that evidence can be fully sifted. The fine dirt appears to have had the following effects (reference should be made to FIG. 1 which shows a typical supply system in the later ships):

- (a) In some ships, gas turbine High Pressure Fuel Shut Off Cocks (HPSOCs) became temporarily jammed, their moving parts having become 'gummed up' by a thin veneer of the fuel degradation products described above. (Ships engineering staffs soon developed a successful technique for the removal of HPSOCs for stripping and cleaning by bathing the offending components in trichlorethylene. In practice there was always sufficient warning of trouble for interference with operations to be avoided.)
- (b) In other ships, elements in the coalescer-filter water separators frequently became blocked and had to be changed.
- (c) No ship suffered both the above effects.

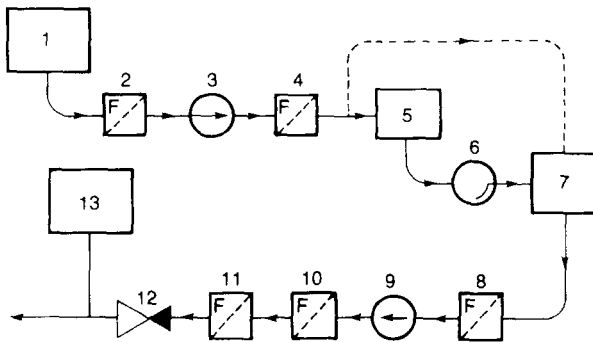

FIG. 1—TYPICAL FUEL SUPPLY SYSTEM IN A MODERN FRIGATE

- Key:
1. Storage tank
  2. 200 mesh strainer
  3. Transfer pump
  4. 300 mesh transfer filter
  5. Settling tank
  6. Centrifuge
  7. Service tank
  8. 200 mesh strainer
  9. Service pump
  10. 5 micron pre-filter
  11. Filter water separator (coalescer)
  12. Pressure reducing valve
  13. Emergency header tank

It is now evident that where coalescers were becoming blocked with particulate matter, they were protecting the HPSOCs and other on-engine fuel system components. This effect occurred almost exclusively in later ships with the more up-to-date coalescers, of a nominal filtration size of one micron. It is true that in most cases coalescers in the earlier ships had been updated by fitting new, finer coalescer elements, but it has since been found that it is easy unknowingly to fit these incorrectly so that fuel can leak past the elements, to the extent that in one or two ships the entire coalescing system has now been found to have been completely bypassed.

In the earlier paper<sup>1</sup> it was reported that contamination of gas

oil by residual fuel was also thought to have occurred. Certainly supporting the Fleet at a distance of 8000 miles was a massive operation, and 32 ships, including a number of oil tankers, had to be taken up from trade. Despite this, contamination of Dieso with Furnace Fuel Oil (originally believed to have been inevitable) is now thought to have been avoided, almost without exception.

For operational reasons, as mentioned above, long periods were spent with engines running at idle or at very low powers, and strip reports of the first engines replaced in ships returning to the United Kingdom indicate in some cases an accumulation of carbon deposits on burners and in combustion chambers. Over the period of the war the amount of carbon built up was insufficient to give any debilitating effects whilst actually running; indeed it is true to say that fuel-related problems were concerned principally with the fuel supply and control systems and only rarely with on-engine fuel pumps or burners. Nevertheless it is evident that there are lessons still to be learnt about the qualities of both present and future fuels and the ability of gas turbines to cope with them.

### Internal Corrosion

A number of ships returned from the South Atlantic with gas generators due for replacement and refit. Examination of these engines had indicated that in some areas corrosion has been worse than expected, particularly in



FIG. 2—H.P. TURBINE BLADE OF NIMONIC 115 (CLEANED)  
from H.M.S. 'Alacrity'

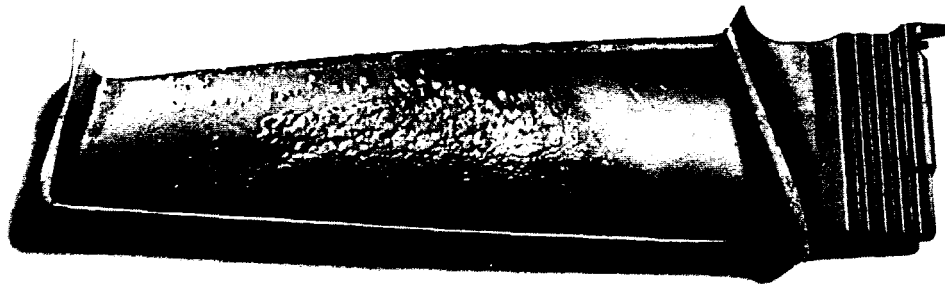

FIG. 3—H.P. TURBINE BLADE OF NIMONIC 115 (UNCLEANED)  
from H.M.S. 'Glasgow'

the hot end. FIGS. 2 and 3 show wrought Nimonic 115 HP turbine blades from two separate Olympus gas turbines taken from two ships of different classes, with differently positioned intakes. Corrosion due to low temperature sulphidation has spread further up the blades than has previously been experienced, particularly on Olympus engines<sup>3</sup>. This and other evidence has added a great deal of weight to the proposal to change to cast INCO 738

HP turbine blades in Olympus. (It should perhaps be made clear that no wrought blade has come anywhere near failure as the result of corrosion, but merely that the blade rejection rate when refitting engines from the first ships to return has been high.)



FIG. 4—H.P. TURBINE BLADE OF CAST INCO 738  
from engine trial at R.A.E., Pyestock

In contrast, FIG. 4 shows a pack aluminized INCO 738 H.P. turbine blade from an Olympus engine after it had run for over 4500 hours at all powers in the Marine Wing of the Royal Aircraft Establishment at Pyestock. Long periods with heavy salt water injection were included. The H.P. turbines of the Tyne RM1C and also the next R.N. engine, the Rolls-Royce SM1A<sup>4</sup>, already employ cast INCO 738 blades as standard.

The factors likely to have led to increased blade corrosion have already been mentioned:

- (a) Contamination of fuel with salt water due to leakage bypassing coalescers.
- (b) The effects of rough weather.
- (c) Possible leakage of air intake filter bypass doors.
- (d) Prolonged running at low powers, when filtration can be inefficient due to low air velocities.

It is now believed that the first of these is likely to have had the most direct influence. As might be expected, none of the engines in the newer frigates and destroyers has yet become due for replacement and, with one exception, the H.P. turbines examined have come from ships with older, less efficient fuel purification systems without in-line centrifuging and with coalescers which may well have been partially bypassed or leaking. H.M.S. *Alacrity* (FIG. 2) is such a ship. The exception is H.M.S. *Glasgow* (FIG. 3) which suffered some damage, as exemplified by FIGS. 5 and 6, and in which there must have been a greater chance of leaking air filter bypass doors due to shock.

## Life

### *Gas Generator Lives*

One area in which Marine Engineer Officers had to be given responsibility greater than before concerned the granting or withholding of an extension to the life of a gas generator beyond the generally approved limit. In comparison with the U.S. Navy, the Royal Navy has so far accumulated a relatively small number of gas turbine hours. The policy has been to approach final life targets cautiously, with only a gradual step by step increase in the number of hours that could be run before engines had to be removed for

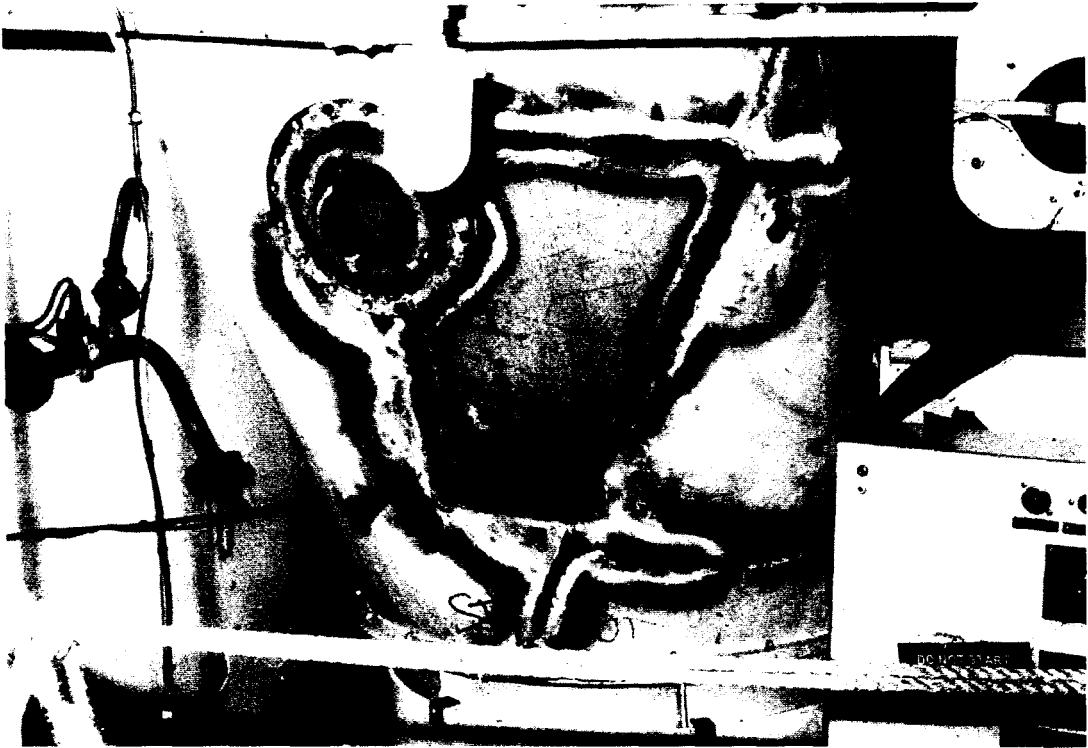

FIG. 5—H.M.S. 'GLASGOW': WELDED REPAIR OF TYNE INTAKE

overhaul. Decisions to extend lives further have been based mainly on examination of engines *in situ* by a shore-based team of experts, and on detailed examinations of life-expired engines during refurbishment ashore. Individual gas generators have been selected as lead engines, acting as vehicles for life sampling. The rest have then followed suit before the next advance has been considered. (This policy was discussed by Piper<sup>5</sup> and Wright<sup>6</sup>, and expanded by Kingsland<sup>4</sup>.) It is known that many people consider this approach too timid, but in the Falklands there is no doubt that it was fully vindicated. There were no over-generous claims of reliable life to complicate the estimates for support requirements, and confidence in the predictions of the minimum lives of the engines at sea was of great advantage in both operational and logistic planning.

Nevertheless it will be evident that, in the circumstances, drastic revisions had to be made to the way in which extensions had previously been granted. With an operational zone 8000 miles from home, ships with engines with less than 2000 hours life remaining would have had to turn around almost as soon as they arrived, so the cautious piecemeal life extension programme was torn up and decisions taken that would normally have required at least two or three years further accumulated running experience — a fair indication of the confidence of the Fleet in the fundamental reliability of its gas turbines. Engine lives (Declared Overhaul Lives) were increased at a stroke — by as much as 50 per cent. in the case of the relatively new Tyne RM1C. With the effect of engine failure being potentially so catastrophic however, it was decided that it would be prudent to grant these further extensions in steps of 500 hours with combustion chamber and hot end inspections by endoscope at each stage. Whenever possible the latter were carried out, as previously, by a team of experts from Fleet Headquarters, but more often than not it was left to the MEO at sea.

The new system worked well. Action damage aside, during the period of the war only two engine failures occurred that warranted changing a complete GTCU, and one of these has subsequently been found to have been based

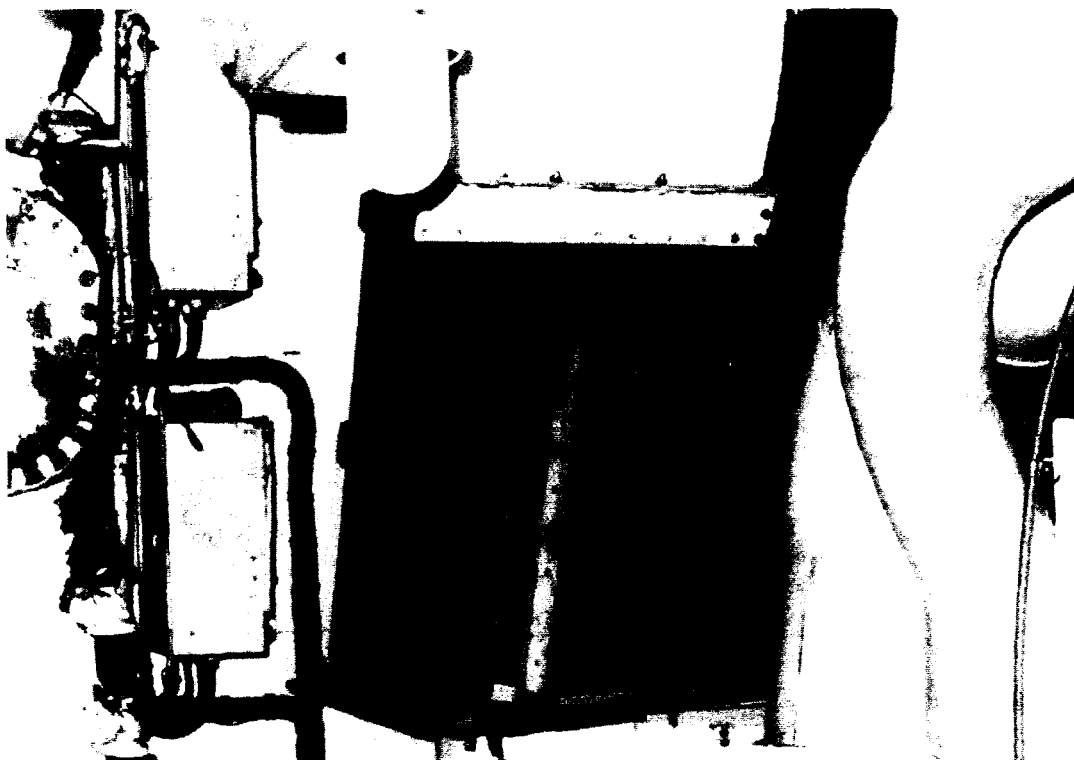

FIG. 6—H.M.S. 'GLASGOW': WOODEN SECTION OF TYNE INTAKE

on a spurious magnetic chip detector reading, analysis of which was delayed by the poor communications with the laboratories in the U.K.

### *Component Lives*

Whilst a prolonging of operations would inevitably have brought overall engine life into greater prominence, as it happened it was the shorter lives of the principal sub-components that were found to be more critical. Before Operation Corporate it had not been the practice for engineering staff in the smaller ships to change their own Olympus combustion chambers at sea; for the Tynes a routine did not exist and one had to be specially produced. In the event, whilst only a few combustion chamber changes by ships staff were necessary, all of them on Olympus engines, those that were carried out took an unexpectedly long time, even when allowance was made for the inexperience of the crews. If hostilities had continued throughout the winter months, more changes would inevitably have been required and the length of time engines would have had to be out of action might well have had operational disadvantages. As a result, urgent investigations are being conducted into extending the lives of combustion chambers and improving the accessibility within the module for their replacement. The target life is that of the engine itself, as it is already in the case of the Tyne RM1A and all but the earliest version of the Tyne RM1C.

## **Maintenance**

### *Routine Servicing*

Under peacetime conditions gas turbines are washed with water as a regular routine once every 24 running hours, when shutting an engine down, and before starting again after inhibiting. Other daily routines include inspections for leaks, tests of fire warning alarm systems, and readings taken from magnetic chip detectors in lubricating oil systems. As the Task Force voyaged south, MEOs were told that they should stick to the basic servicing pattern



as closely as operational conditions allowed. It is apparent from their reports that not only were they successful in this but also, because of their healthy desire to take any early opportunity that presented itself to wash engines in case another did not come up that day, it was not unusual for the frequency of washes to be increased rather than reduced.

### *Planned Maintenance*

TABLE II describes briefly the maintenance routines specified for Tyne RM1C gas turbines. Similar instructions apply to both Tyne RM1A and Olympus. Apart from occasionally increasing the periodicity of a 250-hour routine to 500 hours, ship's staff on the whole managed to fit essential planned maintenance into the operational programme at or near the hours specified, taking engines out of service in turn whenever circumstances permitted. Inevitably, however, some routines had to be omitted and it is evident that it would have been useful for MEOs to have been given a fuller background for the various inspections, so that when time was short they could have been selective with greater confidence. Reports from sea include a recurrent theme — Operation Corporate has re-emphasized the need for ships to be as independent as possible of shore-based support during a crisis in the field, a truism that is as relevant now as it was 40 years ago. As was discussed by Piper<sup>5</sup>, there has been a growing tendency in peacetime to remove detailed technical decisions from ships engineers, a typical example being the philosophy of 'Repair by Replacement' or 'Upkeep by Exchange' discussed below. The Falklands showed once again that, during periods of intensive operations remote from home base, it is the man on the spot and his ability to improvise that really count.

TABLE II—*Periodicity of Maintenance Routines (Tyne RM1C)*

250 hours	1. Inspect and clean scavenge oil filters and anti-icing inlet casing
500 hours	1. Gas Temperature Control System: check continuity of thermocouples and simulate operation of trip relay. 2. Check and functionally test Power Turbine overspeed trip. 3. Inspect and clean P3 delivery line and Air Pressure Control unit filters
1000 hours	1. Clean and inspect fuel and oil filters
2000 hours	1. Visually inspect combustion chambers in situ with endoscope. Remove, clean and replace burners.

### *Breakdown Maintenance*

Ever since the change to marine gas turbine propulsion, the policy for breakdown maintenance has been for 'Upkeep by Exchange'.

Whilst expensive, this was thought to be the most efficient and least demanding on ship's staff. Of course it assumed that ships would have a full stores outfit to start with and that there would be swift replenishment of ship's stocks as they were used up, either by supply from the spare parts organizations back home in U.K. or by pooling the resources for all the gas turbine ships in the area. Under wartime conditions it was found that the swift supply of spares could not always be guaranteed and as a result the ability to repair components on board became increasingly desirable.

This was for a number of reasons:

- (a) The long distance from home.
- (b) The scattering of the force.
- (c) Difficulties in returning defective components to U.K. for repair.

- (d) Variations between the different marks of Tyne engines fitted across the Fleet. (These will slowly disappear over the next few years as the conversion programme to RM1C engines is completed<sup>4</sup>.)
- (e) Not all ships had the opportunity to store fully before sailing from home waters. Many were sent south directly from a deployment for some months away from base, without being able to recover a full stores outfit.

The most critical items were found to be fuel pumps, high pressure shut-off cocks and other components within the on-engine fuel supply and control systems. It was soon realized that emergency routines were necessary to allow local repair and calibration of these equipments, supported by spares of a category low enough to include individual parts, not merely the complete unit. Where such instructions were not immediately available, once again Ships' Staffs were not slow to rediscover the art of improvisation.

In the months since the campaign a partial retreat from this radical revision in repair policy has been necessary for those components that would normally require to be set up on rigs (pressurizing valves, fuel pumps, and governor control units). Naturally ships' MEOs have been keen to retain their new-found freedom; nevertheless it has been considered prudent to define carefully the meaning of the word 'emergency' when applied to the situations where MEOs might be free to risk local repair of sensitive components. 'Emergency' in this case implies that, as far as a replacement is concerned, all avenues have been explored, including supply from home, neighbouring warships or supply vessels, and also that the operational situation makes it vital that the gas turbine is available again before a new item can be obtained.

These caveats apart, repair of most gas turbine sub-assemblies at sea is now recognized as a fundamental requirement and formal instructions and repair kits are being issued.

#### *Engine Changes at Sea*

When, in the initial stages, a long campaign stretching through the Antarctic winter was being planned, it was recognized that it might become necessary to replace engines whilst on station. Before Operation Corporate, the intention had been for engine changes to be carried out, if not in a home port, at least in harbour with full dockyard facilities readily available. In COGOG ships, Olympus and Tyne gas generators are removed and inserted via their intakes. Clearances are tight and proper land-based cranes had always been thought to be essential. However the operational situation soon caused these opinions to be revised and routines were devised to allow an engine to be changed by an itinerant team of specialists deployed in the operational zone, using a combination of a crane in one of the larger ships and jury sheer-legs rigged in the receiving ship.

During the war the plans for the frigates never had to be tested in practice, although they have been since. It was left to the aircraft carrier H.M.S. *Invincible*, with over 5 months continuously on station, to be the first to break new ground. Unlike the smaller ships, H.M.S. *Invincible* provides her own engine 'Change Team', carrying 2 spare GTCUs permanently on board slung in the engine room in pods<sup>7</sup>. What had never been foreseen, however, was that the evolution would be conducted at sea whilst actually under way, it always having been believed that it would be possible only at anchor in a secure harbour. The exit route for a GTCU in the INVINCIBLE Class is not via its intakes but (once the cascade bend has been removed) out of the front of the module, on to a trolley, across the engine room on rails, and up to the hangar on a permanently installed lift. Even so there is a critical period whilst the engine is being transferred from the module to the trolley,

when slinging and securing arrangements must cushion ship movement and machinery and personnel are particularly vulnerable to a violent roll.

Undaunted, during the months following the end of hostilities, the engineering staff of H.M.S. *Invincible* changed 2 life-expired Olympus engines at sea with complete success.

## **Propulsion Availability and Redundancy**

### *Overall Availability*

All ships report that the basic redundancy inherent in a 4 gas turbine fit was of great operational advantage, both when planning routine maintenance and dealing with breakdowns or action damage. The last was demonstrated on a number of occasions during the Falklands campaign and never more poignantly than in H.M.S. *Sheffield*, both of whose Tyne engines were fully operational and one actually running even as she was abandoned, 6 hours after being struck by an Exocet missile.

### *Vulnerability—Gas versus Steam*

A broad comparison can be made between H.M.S. *Glasgow* and H.M.S. *Argonaut*, both of which were damaged by bombs during air attacks. The after engine room in *Glasgow* was partially flooded after a bomb had passed right through it, whilst *Argonaut* was hit close to her boiler room, causing widespread shock damage to machinery and pipework. In the former, both Tynes were put out of action when their intake transition pieces were badly damaged. One was repaired by welding on board (FIG. 5) and the other by fitting a wooden section manufactured in the Frigate Support Vessel (FIG. 6). Even before these repairs had been completed, either engine could have been re-started in an emergency by taking suction from the machinery space, accepting the risk from debris from the shattered trunking or the possibility of the formation of a vortex in the engine inlet. In the event this was unnecessary since throughout the period both Olympus gas turbines (in the separate forward engine room) remained fully available and the ship could continue to manoeuvre as normal. Once fires had been brought under control and the holes in the ship's side fully patched, H.M.S. *Glasgow* was back with the rest of the Fleet and ready for further operations.

H.M.S. *Argonaut*, on the other hand, was without any propulsive power for several hours. Initially she lost steam completely as the main stop valves on both boilers slammed shut through the shock of the explosion, and subsequently her damaged pipework took some time to repair. During this period she was, of course, particularly vulnerable to further attack.

### *H.M.S. 'Invincible'*

H.M.S. *Invincible* is fitted with four 21 megawatt Olympus gas turbines in a COGAG configuration<sup>7</sup>. The broad facts of her marathon five-and-a-half-month voyage between leaving Portsmouth at 1015 a.m. on 5 April and returning at midday on 17 September 1982 have been widely publicized. What is not so well known is the fact that, apart from the final night at anchor at Spithead, she was at sea for all but 16 hours of her time away, the latter being split into 4 or 5 short periods during which the ship still remained available at 10 minutes notice for sea. During the 3-month period of hostilities an average of 20 seconds defect maintenance was required for every gas turbine hour run. This was mostly flame trap cleaning and an investigation is in hand to see if traps are strictly necessary. Naturally full power was not available whilst this and routine planned maintenance and the two engine changes mentioned above were being carried out. Even so, more than four-fifths maximum speed can be obtained on one engine per

shaft and it is true to say that *Invincible* remained operational for every second of her 166 days away, a phenomenal achievement saying much for the reliability of the Olympus and the viability of the single type 4-engine COGAG fit.

Thus the inherent redundancy of a 4-gas-turbine fit proved itself invaluable under wartime conditions. Furthermore there can be little doubt that a 4-engine COGAG arrangement with engines of a single type gives even greater flexibility than COGOG. At least four-fifths full speed remains available on only one gas turbine per shaft (whichever engine is out of action) and there are natural logistic advantages from having only a single engine type to support. There are also increased opportunities for emergency cannibalization of a defective engine to keep others in good running order.

It was concluded in an earlier article<sup>7</sup> that, of the many configurations available, a COGAG fit of 4 identical gas turbines provides a well-balanced solution to the main propulsion conundrum, given the right sized building bricks. H.M.S. *Invincible*'s experience in the South Atlantic in 1982 certainly reinforces this view.

### **The Navy's Next Marine Gas Turbine**

Kingsland<sup>4</sup> describes the Rolls-Royce Marine SM1A at present undergoing a life extension programme after completion of full development in 1982. It is reassuring that many of the requirements for a gas turbine in war raised in this paper are found to have been already built into the SM1A engine:

- (a) Cast INCO 738 HP turbine blades are fitted.
- (b) The fuel control system is basically electronic and thus less vulnerable to poor quality fuel.
- (c) Accessibility within the module is greatly improved.
- (d) The opportunities for repair of components on board or in nearby support vessels are a whole order better than in earlier generations of R.N. gas turbines.

Opportunity has also been taken to introduce other changes arising from Falklands experience.

### **Conclusions**

It is all too easy to forget that there is never a moment when a warship is not liable to be called upon to fight, and no amount of peacetime success can disguise ineptitude in battle. The overall availability of the gas turbine ships of the British Fleet and the reliability of their engines is reflected in the success of Operation Corporate itself. But many lessons have been and still are to be learnt from the campaign, and those considered particularly relevant to the future of marine gas turbines can be summarized as follows:

- (a) Present gas turbine fuel systems are susceptible to poor quality or degraded fuel and, in a period of unexpectedly heavy operational activity, consistently high standards cannot always be guaranteed. Many of the problems experienced in the Falklands are thought to mirror those predicted for future fuels a decade hence.
- (b) Ships' engineers must have sufficient technical information to allow them to be both selective when planning preventive maintenance and inventive when dealing with defects and action damage.
- (c) A blanket philosophy of Upkeep by Exchange has some disadvantages, particularly in wartime. It is always necessary to strike a balance, but it is believed that in selected areas the scale of spares provided should be down-graded to a level that allows greater opportunity for the

repair on board of individual components. At the same time drawings and technical handbooks should be modified to include more detail.

- (d) Maintenance and logistic support is greatly simplified in a ship with only one type of engine to support, particularly in a four-engine COGAG arrangement.
- (e) The lives of components are critical and where possible should match that of their parent engine. Where this cannot be achieved, facilities should allow Ship's Staff to replace components as swiftly as possible.
- (f) Engine availability depends upon ruggedness, reliability, and maintainability. It was these basic qualities in the present generation of Marine Gas Turbines that combined to give such magnificent service during the Falklands campaign. Care should be taken that they are not neglected in the search for even greater operational convenience and fuel economy in the future.

### Acknowledgements

The author acknowledges with thanks the assistance of colleagues in the Fleet, the Staff of the Commander-in-Chief Fleet, the Ministry of Defence, and Rolls-Royce Ltd.

The views expressed are the author's and are not necessarily those of the Ministry of Defence.

### References

1. Ridley, P.W.W.: Royal Naval marine gas turbines in the South Atlantic in 1982; *A.S.M.E. Gas Turbine Conference, Phoenix, 1983*, Paper no. 83-GT-19.
2. Defence Standard 91-4/issue 4: 'Fuel, naval, distillate . . . NATO Code No: F-76'; 1980.
3. Carter, P.: The correlation of HP turbine blade corrosion attack in dissimilar marine gas turbines; *Fourth Conference on Gas Turbine Materials in a Marine Environment, Annapolis, 1979*.
4. Kingsland, J.M.: Marine gas turbines in the Royal Navy 1978-1979; *A.S.M.E. Gas Turbine Conference, New Orleans, 1980*, Paper no. 80-GT-103.
5. Piper, M.H.: The Royal Navy's experience of Rolls-Royce 'Olympus' and 'Tyne' main propulsion gas turbines; *Institution of Mechanical Engineers Conference on Gas Turbines — status and prospects, 1976*, Paper no. C5/76, pp. 57-63.
6. Wright, G.P.: Logistic support of aero derivative marine gas turbines in the Royal Navy; *A.S.M.E. Gas Turbine Conference, New Orleans, 1976*, Paper no. 76-GT-44.
7. Ridley, P.W.W.: H.M.S. 'Invincible' the main propulsion system; *Journal of Naval Engineering*, vol. 27, no. 1, June 1982, pp. 38-49.