

# THE TYPE 23 FRIGATE

BY

M. B. HAWKE, C.ENG., F.R.I.N.A., R.C.N.C.  
 COMMANDER N. J. MILLS-HICKS, C.ENG., M.I.E.E., M.I.MECH.E., R.N.  
 COMMANDER W. B. HARRIS, B.SC.(ENG.), C.ENG., M.I.MAR.E., R.N.  
 J. R. SCOTT, B.SC., C.ENG., M.I.E.E., R.C.N.C.  
 L. SHEPHERD, B.SC., M.SC., C.ENG., M.R.I.N.A., R.C.N.C.  
 (*Sea Systems Controllerate*)

COMMANDER J. P. BULLARD, B.SC., M.SC., C.ENG., F.I.MAR.E.,  
 M.I.MECH.E., M.I.NUC.E., D.M.S., R.N.  
 (*Directorate of Operational Requirements (Sea)*)

*This article is based on the presentation given by the authors at the Royal Naval Engineer Officers' Conference on 4 May 1984.*

## Operational Requirements

### *Introduction*

To lead off the presentation on the Type 23 frigate, first some words on the operational requirement. The scale of ASW operations has continuously expanded over the last 40 years. The Soviet submariner can now fire missiles at us from long range, and the areas occupied by ASW forces and the convoys they protect are gigantic.

Despite the large sums in roubles and dollars which have been spent on research, sonar remains the most effective underwater detection method. The main distinguishing feature of the Type 23 is its towed array (FIG. 1) which provides the long range passive detection of submarines.

The Type 23 will need a weapon system which can speedily search for and attack enemy submarines. This will be provided by the large helicopter EH101, the Sea King replacement, carrying sonobuoys and the Sting-ray light-weight torpedo.

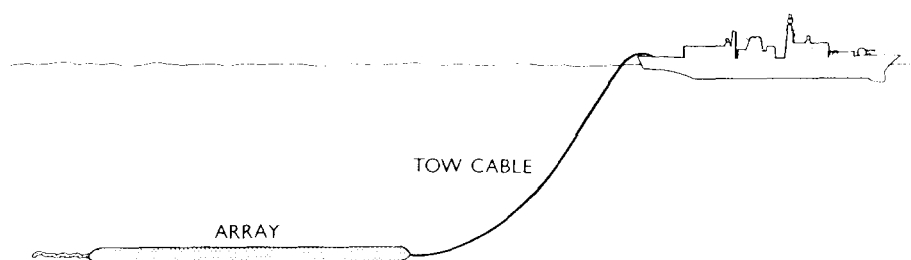

FIG. 1—TOWED ARRAY: NOT TO SCALE

### *Evolution of the Requirement*

We have moved a long way in the design of the Type 23 frigate since February 1980 when the Controller reported that the Admiralty Board sub-committee had endorsed the concept of a towed array light frigate. It is interesting to note the outline requirements as they were then:

- (a) Cost—half the price of a Type 22.
- (b) Equipment fit:
  - (i) Towed array sonar.
  - (ii) Hull-mounted sonar.
  - (iii) Gun with high rate of fire.
  - (iv) Facilities to land, refuel, and re-arm a large helicopter.
- (c) Propulsion system—suitable for sprint and drift with high endurance.

An artist's impression of this early version of the Type 23 is shown in FIG. 2.

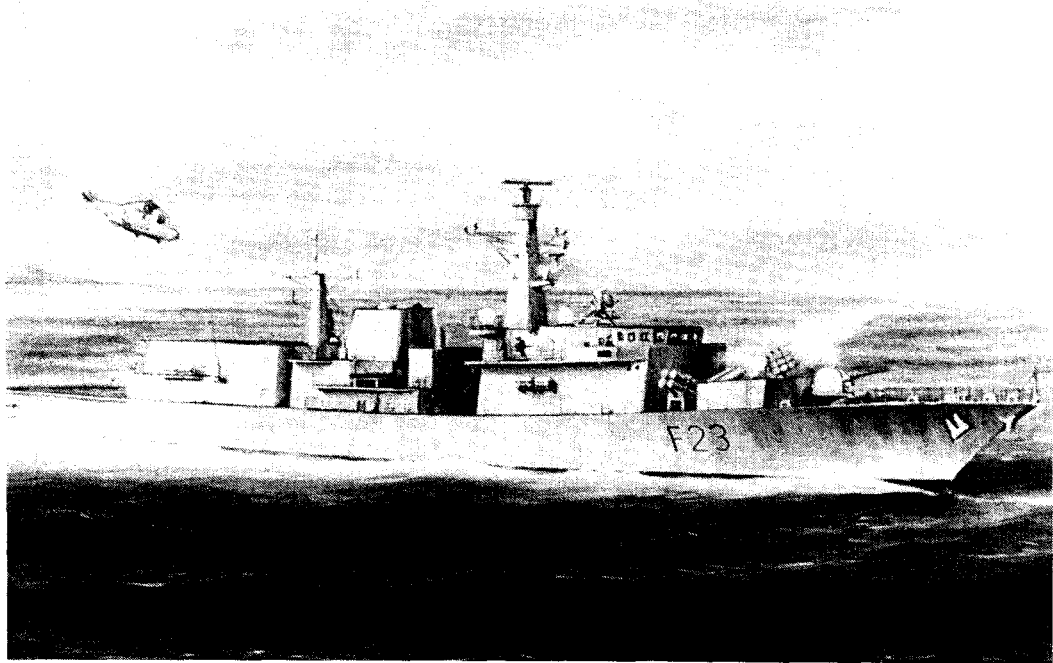

FIG. 2—ARTIST'S IMPRESSION OF TYPE 23 FRIGATE

The Outline Staff Target (OST) was endorsed in spring 1981 and called for 'A least expensive light frigate that is highly capable in ASW operations, deploying towed array'. Notable for their absence from this target were a point defence missile system, surface-to-surface Guided Weapon System (SSGW), and a helicopter hangar. Savings were also expected from a reduced complement, minimum command and control facilities, and a reduced top speed of 25 knots.

The Naval Staff Target (NST) was endorsed in November 1981. There were two major constraints on the design at this stage:

- (a) Unit cost of £67M (at 1980 price levels).
- (b) Accommodation for 165 Officers and Ratings.

An uneasy feeling was however developing in the Naval Staff about the relatively low capability being asked for, and subsequent studies considered options for additions to the weapons fit within an overall cost of £75M.

The result was a more capable ship. The hull length increased, Sea Wolf

and an SSGW System were included as well as a hangar with limited second-line maintenance facilities. The Naval Staff Requirement (NSR) which incorporated these changes was submitted to the Central Committees for endorsement and then to the Secretary of State for Defence for approval early in 1982. During this process a number of further additions were made:

- (a) 3 metres added to the hull length to accommodate the Sea King helicopter.
- (b) A second Sea Wolf tracker.
- (c) A second Spey (SM1A) gas turbine to increase the top speed.

The financial constraint however set a clear limit on the number of enhancements which could be included and it was necessary to resist the constant pressure to further improve the capability.

The Argentine invasion of the Falklands, however, triggered further modifications which resulted in the final design, more or less as shown in the artist's impression printed in an earlier article<sup>1</sup>. By late 1982 the performance of our ships in the South Atlantic had been assessed and many of the lessons learned were applied to the design, in particular:

- (a) Replacement of the 76 mm gun with the Mk.8 4.5 inch for naval gunfire support.
- (b) More emphasis on smoke and fire containment.
- (c) Improved splinter protection.
- (d) Considerably reduced compartment linings.
- (e) Mess decks resited high in the ship to speed movement of personnel to action stations.
- (f) Improved HPSW system.

In the meantime also:

- (a) The Sea Wolf system was changed to vertical launch.
- (b) The SSGW was decided as Harpoon, which had just been approved.

Following the incorporation of all these changes into the design, Admiralty Board Approval for the Type 23 was obtained in Autumn 1982.

### **Cost and Programmes**

The Design Contractors, Yarrow Shipbuilders Ltd., are now designing the Type 23 frigate, except in those areas where specialist knowledge is to be found only in MOD, and also in the weapon system areas. Yarrows in turn are sub-contracting parts of the design, for instance the gearbox, to the equipment suppliers, in this case GEC Industrial and Marine Gears.

Substantial reductions in cost (compared with the Type 22 frigate) have been achieved by:

- (a) The Naval Staff reduced requirement, e.g. manning levels reduced by 100.
- (b) The design contractor has been required to tender competitively for almost all the major equipments in the ship.
- (c) Batch ordering of long lead equipments has also allowed some price reductions, particularly where a long term order was an attractive prospect to the supplier. This also leads to identity of ships which in turn reduces shipyard production problems.
- (d) Finally, the design contractor has been encouraged to offer commercial equipments wherever these meet the requirement and allow a cost saving. In the present climate 'gold plating' must be avoided but only those equipments deemed 'fit for purpose' will be allowed to substitute for existing proven equipment.

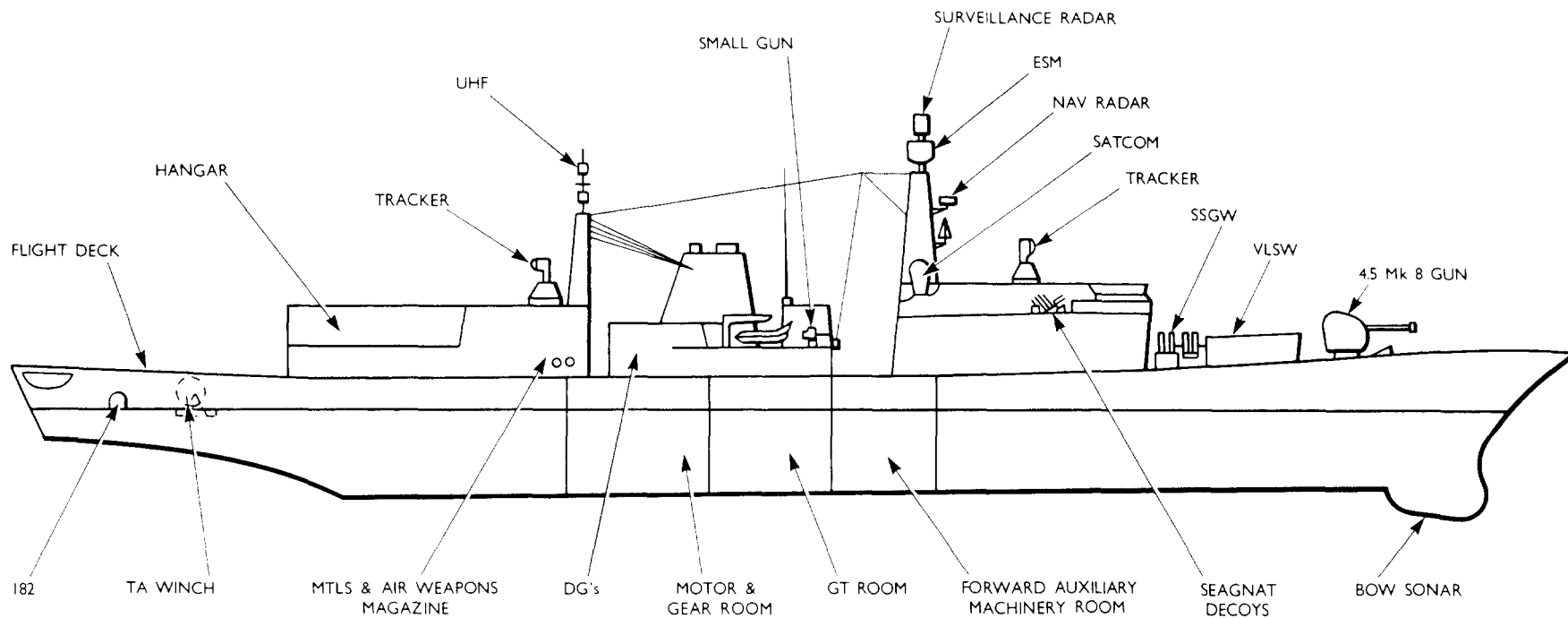

FIG. 3—TYPE 23: PRINCIPAL FEATURES

The basis for ordering the Type 23 assumes 8 identical ships, each costing an average of £98 M at 1981/82 prices. The reader will observe that the cost has grown somewhat as the ship has developed. Inherent in the price assumption is that the First of Class will cost more than the average—about £102M. Thus, although this is a cost-constrained ship, it is not a cheap ship.

### **The Design of the Platform**

The major factors affecting the Type 23 design were:

- (a) The requirement for a quiet platform to ensure that the radiated noise did not interfere with the Towed Array (TA). This requires a propulsor which does not cavitate at the maximum towing speed, and was achieved with a conventional propeller, as opposed to a pump jet, using two large diameter slow-revving fixed pitch propellers.
- (b) The ship is to operate a helicopter capable of locating and prosecuting targets at the extreme detection ranges of the Towed Array and the helicopter is much larger than those previously operated from R.N. frigates. Furthermore, helicopter operations are required in high sea states without the need to change course to a more favourable heading. The hull form was developed using the GODDESS computer programs (at Bath) to minimize ship motions. In addition an aircraft and weapons handling system is being developed to move the aircraft and weapons safely to and from the hangar with minimum manpower.
- (c) The maintenance facilities required to keep the aircraft serviceable. Many levels of facilities were considered and the final selection was a fixed hangar with limited second-line maintenance.

The principal features of the Type 23 are shown in FIG. 3. 123 metres was considered to be the minimum length for a satisfactory upper deck layout. At this length the Type 23 should just fit into the Frigate Complex at Devonport. The beam was selected to provide adequate stability with no fuel restrictions.

There is accommodation for the complement of 147 plus a margin of 38, making a total of 185.

The flight deck is sized for Sea King and EH101. An amidships flight deck was considered but obstructions there at both ends of the flight deck would have required it to be about 50 per cent. longer. Consideration was also given to siting the TA winch on the quarter deck but this would have obstructed the after end of the flight deck, again requiring a longer flight deck. The hangar can accommodate either EH101 or Sea King. The air weapons magazine is sited forward of the hangar on 1 Deck to avoid the cost of a weapons lift. The arrangement has also allowed for the torpedo tubes to be incorporated into the magazine and a semi-automatic air weapons handling system is being developed for this magazine. The gap between the air weapons magazine and the upper deck machinery space (containing diesel generators etc.) will provide a firebreak as well as athwartships access. The upper deck machinery space was chosen to reduce the extent of noise reduction measures required and hence the cost. Early arrangements without a hangar had all 4 diesel generators sited on 1 Deck. The gap forward of the downtakes provides the necessary clear area aft of the excited foremast, a removal route for the forward diesel generators, and a RAS dumping area.

Consideration was given to siting the SSGW in this gap but there was concern about RADHAZ and the danger of the ship breaking its back if a hit in this area caused detonation of the SSGW. Consequently, SSGW was moved to the site now shown forward of the bridge. The bridge superstructure block houses the officers' accommodation. The SSGW was mounted athwartships to provide 360° cover. The Seawolf block was developed to accommo-

date either vertical launch Seawolf or a conventional launcher with minimum change. The gun is a standard 4.5 inch Mk.8 gun.

The superstructure sides have been sloped to reduce the Radar Cross Section (RCS) of the ship. The selection of upper deck equipment will take RCS into account.

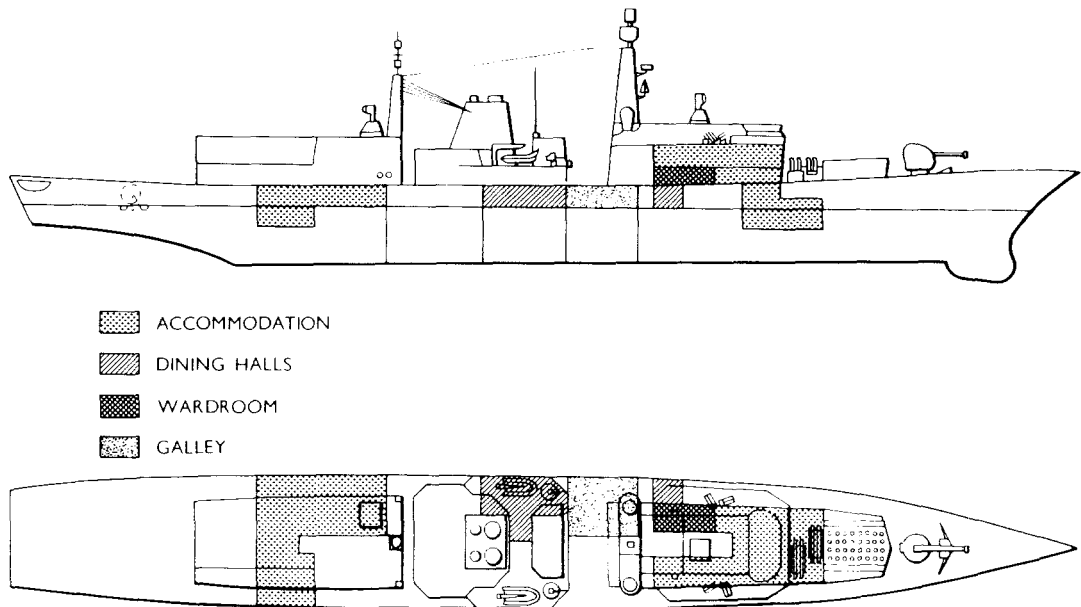

FIG. 4—TYPE 23: ACCOMMODATION AREAS

FIG. 4 shows the location of accommodation areas. Care has been taken to avoid the ends of the ship where motions are more severe, noisy areas in the vicinity of machinery spaces, and vibration areas above the propellers. As much accommodation as possible has been sited on 2 Deck to minimize flow of traffic from 3 Deck to 2 Deck in high action states. Consideration was given to providing mixed junior rates and senior rates accommodation both forward and aft, but this was found impracticable. Junior ratings are located in 4 messes aft. Senior ratings live forward in 2-, 4- and 6-berth cabins.

Cost considerations led to the choice of a single galley amidships supplying dining halls forward and aft and the wardroom above.

Compartment linings will be restricted to those areas where medical and hygiene requirements dictate, and the accommodation areas will be somewhat more austere than in the Type 22.

Design lessons resulting from the Falklands War have been listed already. Two of the areas of major change from previous design practice are:

- (a) Ventilation. FIG. 5 illustrates how the ship's air conditioning system is grouped into 5 separate sections, each with its own Air Filtration Unit, to minimize the spread of smoke, blast, and fire. Ventilation trunking is not permitted to cross these smoke zone boundaries. The ship will operate with these zone boundaries closed in high action states. Good vertical access is provided within each zone. In addition, all main transverse bulkheads will be made watertight up to 1 Deck, a practice not followed in recent designs.
- (b) HPSW System. This system has the traditional ring main with the following improvements:
  - (i) A low level cross-connection has been provided.

- (ii) There are 5 electric HPSW pumps and the centre 3 pumps have Y risers to allow these pumps to feed either side of the ring main.
- (iii) Diesel-driven pumps are provided forward and aft and are permanently connected to the ring main.
- (iv) Emergency power for the electric pumps is available from the salvage generator via low level cable runs.
- (v) Local starting of pumps is provided.
- (vi) Remotely controlled valves are fitted to allow rapid reconfiguration from the SCC. Valves will also be operable from 1 Deck by rod gearing.

Under normal conditions only two HPSW pumps will be running, to minimize the transmission of noise into the water. Further pumps may be started sequentially as required.

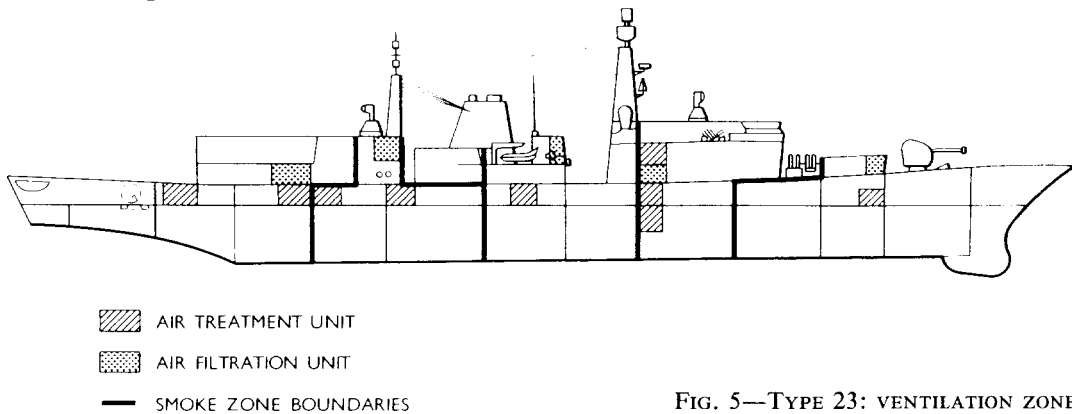

FIG. 5—TYPE 23: VENTILATION ZONES

### Propulsion Machinery

The propulsion machinery of the Type 23 has been the subject of previous articles<sup>1, 2</sup>. Additional information is presented below on the main electrical propulsion and power supplies and on the Ship Control Centre (SCC) where further developments have taken place.

In addition the one-fifth scale machinery space models are now partially complete (see FIG. 6).

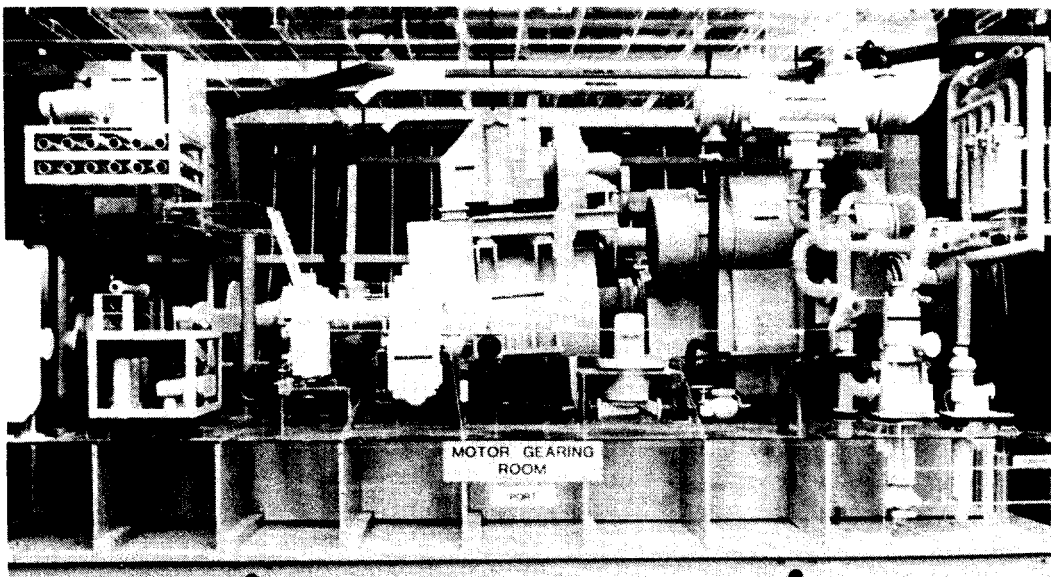

FIG. 6—ONE-FIFTH SCALE MODEL OF TYPE 23 MOTOR GEARING ROOM

### Main Electrical Power Supplies

The CODLAG machinery fit has sometimes been described as a novel arrangement, but the R.N. has a good deal of experience of electrical propulsion for low noise performance in submarines, trials ships (e.g. R.M.A.S. *Newton*), and the 'H' Class survey vessels.

There were many engineering options available for the propulsion and main electrical supply systems, and the final choice followed about 9 months of feasibility studies. The logic of the selection was broadly as shown in FIG. 7, that is:

- (a) An integrated propulsion and ships service supply system. This minimizes the number of prime movers, gives good flexibility and power utilization, and has power always available for crash stops.
- (b) Direct drive rather than geared motors in order to avoid gearbox noise.
- (c) d.c. motors rather than a.c., chosen for quietness and ease of speed control.

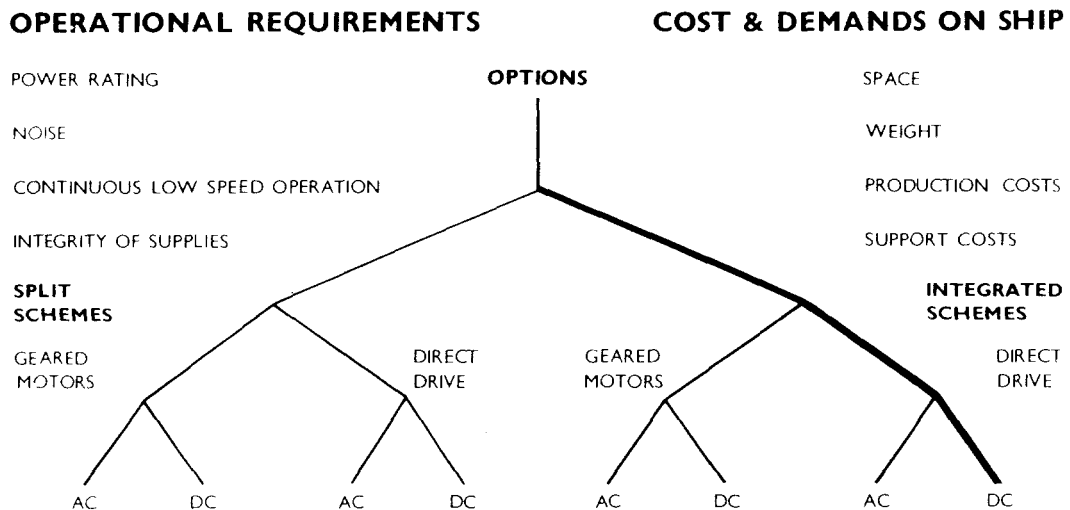

FIG. 7—ELECTRIC PROPULSION AND MAIN SUPPLY SYSTEM: LOGIC OF SELECTION

The final configuration decided upon for the electrical propulsion and main supply system is shown in FIG. 8:

- Four 1.3 MW generators at 600 volt a.c. 61 Hz (61 Hz to accommodate slip in the motor-generator set) with two switchboards and a single main interconnector.
- Two 945 KW motor-generator sets supplying high quality 440 volt 60 Hz weapon and ship services.
- Two thyristor converters and propulsion motors rated at 1.5 MW.

Control of the shaft speed of the d.c. propulsion motor is achieved using thyristor converters which rectify the a.c. from the ships integrated supply system, and are also able to vary the d.c. voltage applied to the motors to give a modern equivalent of the Ward-Leonard speed control method.

The chopping of the power supply waveform by the thyristors gives rise to power supply distortion outside the warship guaranteed limits of DEF STAN 61-5<sup>3</sup>, and can also produce electromagnetic interference effects. For these reasons the two motor-generator sets are installed to give the required quality of power supply waveform, and also as a means of isolating conducted interference voltages.



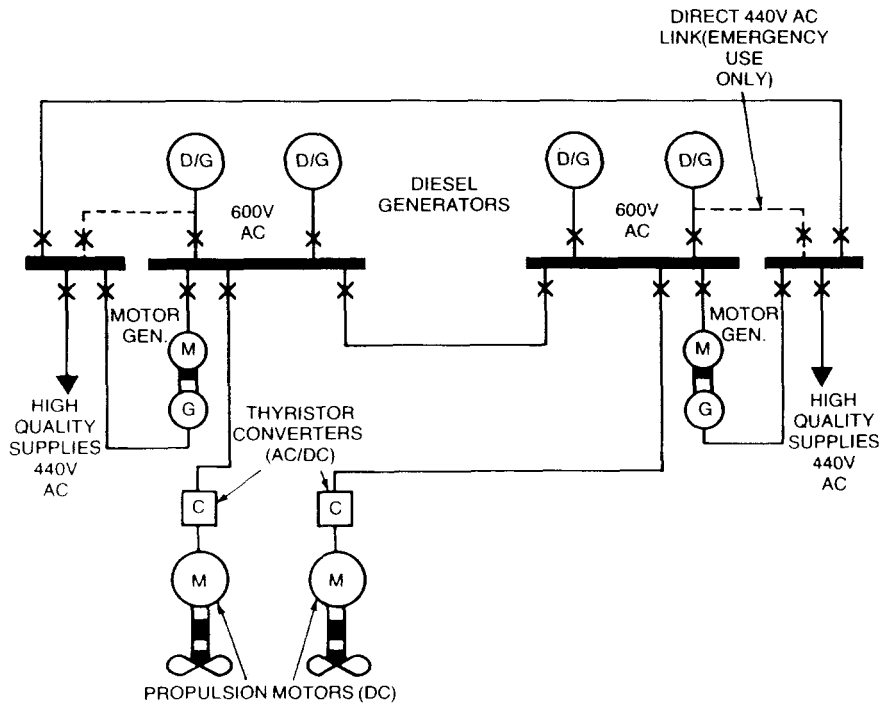

FIG. 8—ELECTRIC PROPULSION AND MAIN SUPPLY SYSTEM

The total ships service loads predicted for the Type 23 are somewhat higher than would normally be expected for a ship of this size; this is because the hotel load is all-electric and there is no auxiliary steam system. The total connected ship's service load, excluding the propulsion motors, is greater than in the Type 22, Batch I. In order to meet the design cost constraints, strict budgets have been applied to both chilled water system and the electrical power system. At the outset of design both systems effectively had a 10 per cent. design margin with zero life margin, compared with 25 per cent. and 20 per cent. for previous classes.

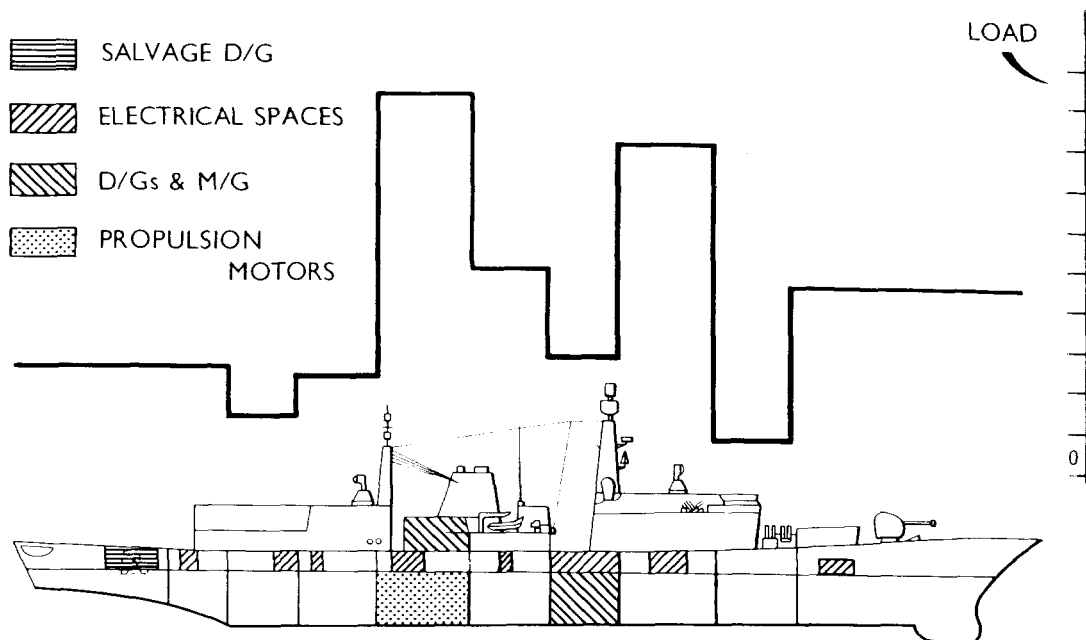

FIG. 9—DISTRIBUTION OF CONNECTED ELECTRICAL LOAD ALONG THE SHIP

The 600 V electrical system is designed for continuous parallel operation with start-up of diesels on demand, auto-synchronization of sets and automatic load-shedding in order to achieve flexibility of operation and to minimize running hours. The siting of the diesel generators, switchboards, Electrical Distribution Centres and the emergency generator is shown in FIG. 9. To get some idea of the most suitable sites for Electrical Distribution Centres and thus minimize the amounts of power cabling, the distribution of connected load along the length of the ship is plotted in the same diagram. As can be seen, most load is concentrated around the centre of the ship, even excluding the electrical propulsion motors. In order to improve flexibility of operation each EDC is supplied from both the forward and aft switchboards.

Because the propulsion system and the electrical main supply system are integrated and highly interdependent, the control system must be designed

TABLE I—Type 23 Electrical Equipment Procurement

Equipment/Task	Equipment supplied to Yarrows Shipbuilders by
600 V system specification	GEC (Electrical Projects)
Generator sets	Brush Electrical Machines via Paxman Diesels
Switchboards & controls	Vosper Thornycroft (U.K.), Controls Division
Motor-generator sets	Laurence Scott & Electromotors via GEC (Electrical Projects)
Propulsion motors	GEC (Large Machines) via GEC (Electrical Projects)
Propulsion motor converters	GEC (Industrial Controls) via GEC (Electrical Projects)
Machinery control system	Vosper Thornycroft (U.K.), Controls Division

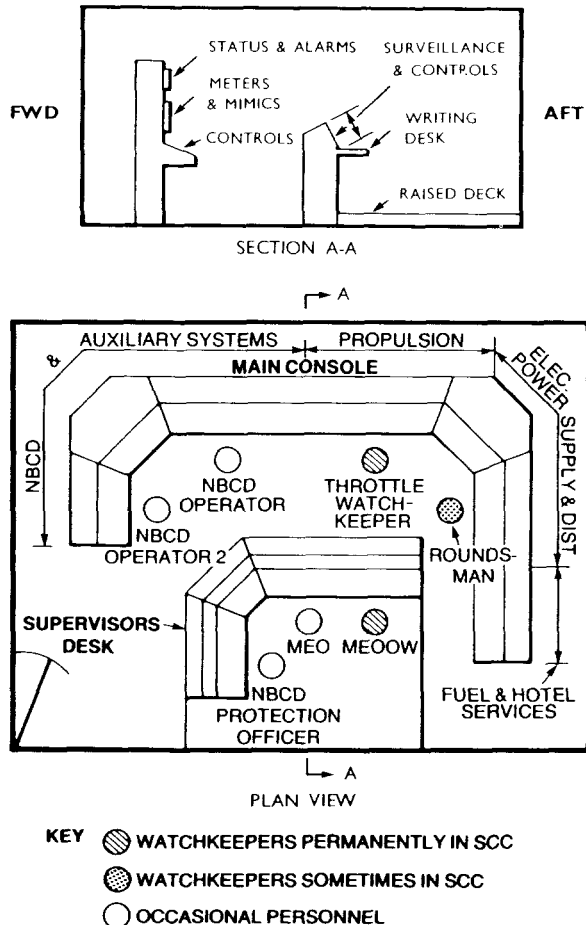

FIG. 10—LAYOUT OF SHIP CONTROL CENTRE

to give high integrity protection, so that large propulsion power demands do not cause a complete electrical black-out, and so that load switching on the power distribution system during manoeuvring does not cause loss of propulsion power. The integrated control and surveillance system will comprise:

- (a) Primary control and surveillance of propulsion plant, main supply system, and auxiliary machinery.
- (b) Secondary surveillance to provide back-up diagnostic information.

The selected system will be digital and microprocessor-based with multiplexed data links between the local control units and the primary control positions in the SCC. The equipment will be based upon the Vosper Thornycroft D86 controls system that was developed initially for marine use and has been used in a patrol craft built by Lerssens in Sweden.

The equipment procurement has been the subject of competitive tenders and TABLE I shows which manufacturers are supplying the major items of electrical equipment. Because of their expertise in the electrical propulsion area, GEC (Electrical Projects) are co-ordinating the supply of the major items associated with the propulsion system.

The cabling for the Type 23 will be from the new range of low fire hazard cables. These have been developed primarily to be 'halogen-free and non-toxic'. Also cables with a copper cross-section of less than 2.5 sq. mm. (by length 90 per cent. of the ship's cables) use thin-wall insulation so that a reduction of about 40 per cent. in the cross-sectional area of cable routes can be achieved.

### *Ship Control Centre*

The Type 23 will have a Marine Engineering complement of 1 officer and 27 ratings, made up of 5 CPOs, 5 POs, 6 LMEMS and 11 MEMs. The complement has been addressed at greater length by Commander Stone<sup>4</sup>. When cruising in DC state 3 it is intended to operate with a three-man watch augmented as necessary by a 'tanky'. FIG. 10 shows the layout of the SCC; the compartment is designed for two man operation, the third watchkeeper being a roundsman. The EOOW will be seated at the supervisor's desk and the propulsion panel operator at the propulsion control panel section of the main console. In Electric Motor (EM) drive it is envisaged that the EOOW will be a suitably qualified PO. In gas turbine and CODLAG drive, the EOOW is likely to be a first class artificer. The propulsion panel operator will be a LMEM.

The propulsion panel is shown in FIG. 11. This illustrates the form of mimic to be used, viz. the gas turbine instrumentation and controls are at

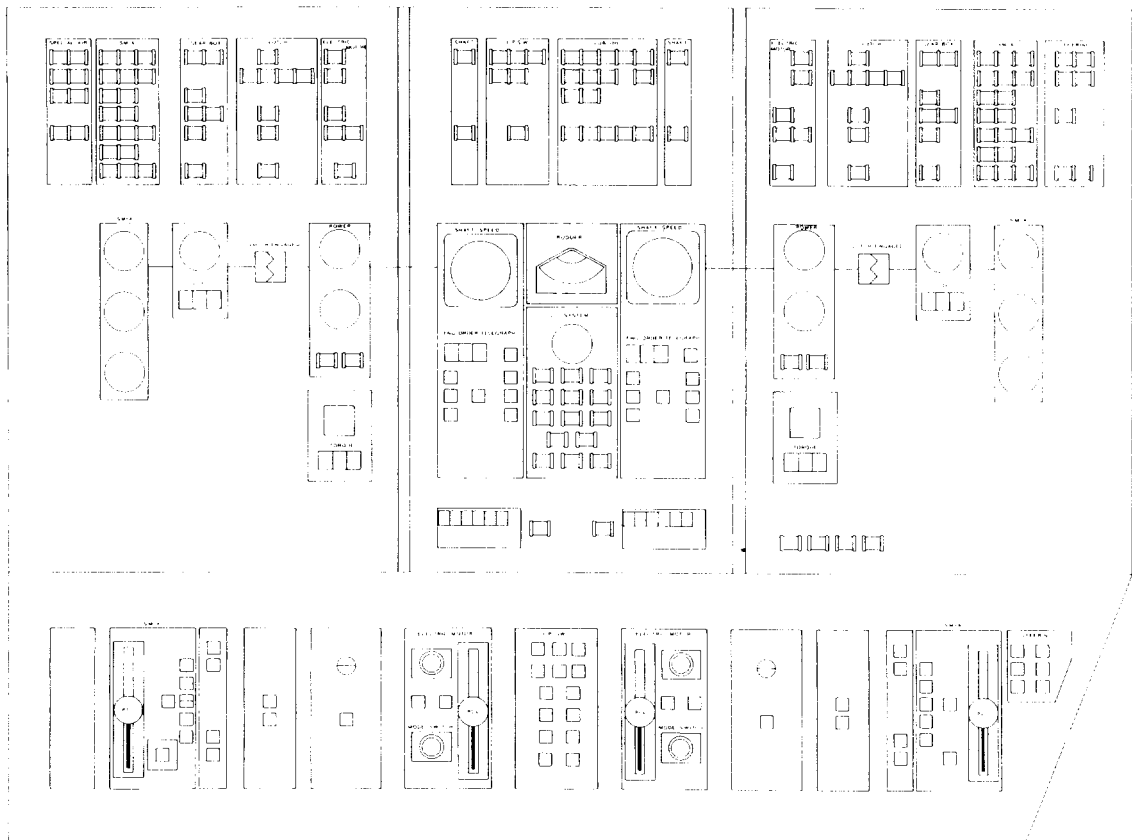

FIG. 11—PROPULSION PANEL IN THE SCC  
ADFL: Air-Driven Forced Lubrication  
LO: Lubricating Oil  
LPSW: LP Sea Water

the extremities of the panel and, moving towards the centre, there are clutch, motor, and shaft instrumentation and controls. The control system provides single lever power control for gas turbine, CODLAG, and EM drive as shown. The operator controls the power applied to the main motors within the limits imposed by the ship's service load and the power available from the number of running generators. Mode changing between CODLAG and EM drive is controlled automatically dependent on the mode selected at the mode selection switch, power control lever position, shaft speed, and power turbine speed.

The SCC has been designed systematically by first of all developing a functional definition of the work required to be carried out in the SCC and then by addressing the operator requirements to meet the identified tasks. In general the design has been optimized to meet the needs of the EOW and MEO. It can be seen that the propulsion panel layout breaks with previous practice in COGOG ships in that the status indications, warnings, and alarms are separated from parameter instrumentation. They are situated at the top of the panels directly above related parameter instrumentation and controls. This allows the EOW a clear view of all status, warnings, and alarms by a top scan around the console. The main console panels show all the information necessary to operate the main propulsion plant from the SCC. This is termed 'primary information'. Additionally, there is a large amount of information available to the EOW on the 'Secondary Surveillance' System. This is a digital data-processing system that will provide engine order, alarms and warnings, and data-logging facilities. Channel information, including historical trends, can be accessed using VDUs and associated keyboards. One VDU and keyboard will be situated on the supervisor's desk and one will be on the primary electrical control panel of the main console.

The facilities provided in the SCC will enable the ship to be operated in a safe and efficient manner and they represent a significant advance over provisions in current ships.

#### *References*

1. Blackman, R. S.: Type 23 frigate—the engineering development; *Journal of Naval Engineering*, vol. 28, no. 1, Dec. 1983, pp. 5–15.
  2. Scott, A. J.: The Type 23 frigate electrical design; *Journal of Naval Engineering*, vol. 28, no. 3, Dec. 1984, pp. 474–477.
  3. Defence Standard 61–5: 'Electrical power supply systems below 600 volts. Pt. 4 Power supplies in surface ships and submarines'.
  4. Stone, P. McL. B.: Type 23 support; *Journal of Naval Engineering*, vol. 28, no. 3, Dec. 1984, pp. 516–520.
-