

Long- and short-term peak shaving of ESS to reduce fuel and maintenance costs of hybrid ships

Krishna Kumar Nagalingam^{*}, Ketil Land^a, Bjørn Egil Evensen^a and Mersudin Horic^a

^aEnergy Product and Engineering, Kongsberg Maritime AS, Kirkegårdsveien 45, Kongsberg, 3616, Viken, Norway. Tel.: 32285000

Corresponding Author. Email: krishna.kumar.nagalingam@km.kongsberg.com

Synopsis

The use of fossil fuels and pollution in the maritime industry have become large concerns in recent years. There are several vessels that are operated with multiple engines at a low to medium level of utilization to meet the redundancy requirements and to handle the fluctuating loads from heavy consumers and the environment. This increases fuel consumption, emissions, and maintenance costs. A reduction in the number of online engines will reduce the operating costs of the power plant without negatively affecting its reliability. The ESS are a reliable alternative energy source that ensures instantaneous power in the event of a power failure. By using ESS, fewer engines can run at optimal or high load levels, avoiding load shedding, or phasing back of a large drive at the onset of a heavy consumer. In traditional peakshaving, the ESS will take all when the load peaks in the whole operating range of genset to avoid changing frequency. Our paper defines peakshaving into two different category namely, long- and short-term. The long-term peak shaving occurs when the battery assists in preventing standby starts of a genset during periods of changing high load. The short-term peakshaving is the period in which battery assist gensets during a heavy consumer start and assist in avoiding load spikes on gensets running at high loads which might cause load shedding. In this paper, we analyse how the short- and long-term peakshaving function of ESS reduces fuel consumption and maintenance costs. Using simulations of typical marine operational loads, this paper discusses the benefits of long- and short-term peakshaving functions of ESS that results in improved engine health, reliability, and fuel consumption.

Keywords: Peak Shaving; ESS; State of Charge; Long-and Short-term peak shaving

1. Introduction

IMO has adopted mandatory measures to reduce emissions of greenhouse gases from international shipping under IMO's pollution treaty (MARPOL) supporting sustainable operations at sea. The Energy Efficiency Design Index (EEDI) was made mandatory for new ships and the Ship Efficiency Management Plan (SEEMP) for all ships at MEPC 62 (July 2011) with the adoption of amendment to MARPOL Annex VI (IMO, 2011).

Author's Biography

Krishna Kumar Nagalingam Krishna is a Product Advisor at Energy and Products Engineering in Kongsberg Maritime. He has Doctorate degree and has worked on several major projects including hybrid and alternative fuels.

The EEDI for new ships is the most important technical measure and it aims at promoting the use of more energy efficient equipment and engines. The EEDI requires a minimum energy efficiency level per capacity mile for different ship type and size segments (IMO, 2016). It is defined by the amount of CO₂ emission per capacity mile. In addition, the Energy Efficiency Ship Index (EEXI), adapted from EEDI, is focused on existing and operational vessels, where the amount of CO₂ emissions per cargo ton and mile (IMO, 2009) is calculated. From 2023 (IMO 2021), the monitoring tools Carbon Intensity Indicator (CII) and Energy Efficiency Operational Index (EEOI) are applicable for vessels.

In order, to meet these regulations, several solutions are being investigated and demonstrated including alternative fuels, optimization of power system, hybridization, improvements in hull design and operational philosophy (Nielsen, 2019). Hybridization has been widely accepted as promising technology towards energy efficient operations that can reduce the fuel and maintenance costs. The potential benefits of ESS include: to boost the available supply of power at times of maximum demand or in case of genset failures (Spinning Reserve), to avoid loading down the gensets excessively which causes high fuel consumption (Peak Shaving), to achieve a more even loading of the gensets (Load Leveling); to allow gensets to run at the most economical load levels and reduce the number of gensets required onboard; to supply on-demand power to equipment as needed (such as heavy consumers like crane, cargo pumps, thrusters etc..) and to provide propulsion power at very low speed transit operation as well as in high-sea emergency operations (DNV, 2018).

As mentioned above, the ESS serve a variety of functions however there are two main functions that contribute towards the fuel consumption and emissions of the ship namely, Load leveling and Peak Shaving. In load leveling, the ESS will at all times try to load the gensets at optimal loading. If the system load is lower than what the gensets can produce, the ESS will use the surplus energy and charge the batteries. It will continue to do until the ESS reaching their maximum energy level. If the system load increases, the genset will provide power according to the optimal load setpoint. The battery will provide power exceeding the load setpoint of genset (Lu Y, 2019).

Peak Shaving is used in applications where the ESS shall limit the rate of change of genset power. This is achieved by allowing ESS to control the genset load. In the conventional peak shaving, ESS will deliver power when the system load exceeds the operating range of the gensets. However, this does not allow the system to run with fewer engines especially at dynamic load conditions.

This paper aims to establish a new definition for peak shaving namely, long- and short-term. It also provides simulation results using a typical marine operational loads of an offshore support vessel. The results from conventional ESS peak shaving mode and proposed long- and short-term peak shaving mode are compared and reviewed in terms of achieved fuel oil consumption and emission reductions.

The paper is divided into 5 sections. The studied hybrid power system and the load profile of the system are discussed and analyzed in section 2. In section 3, the simulation setup for conventional peak shaving and proposed peak shaving approaches are detailed. Section 4 presents the results and discussions from the simulation. Finally, the work is concluded in section 5.

2. Hybrid Power System Configuration

In this paper, an offshore support vessel was selected for simulation. This vessel needs station-keeping capability, during their operations namely lifting, ROV, pipelay, cable

lay etc., In addition, such vessels have transit operations between the port and field. These vessels are fitted with diesel-electric power generation and distribution (Adnanes, 2004). A 690V battery hybrid power system with a radial-main bus in AC system is proposed for this work as shown in Figure 1.

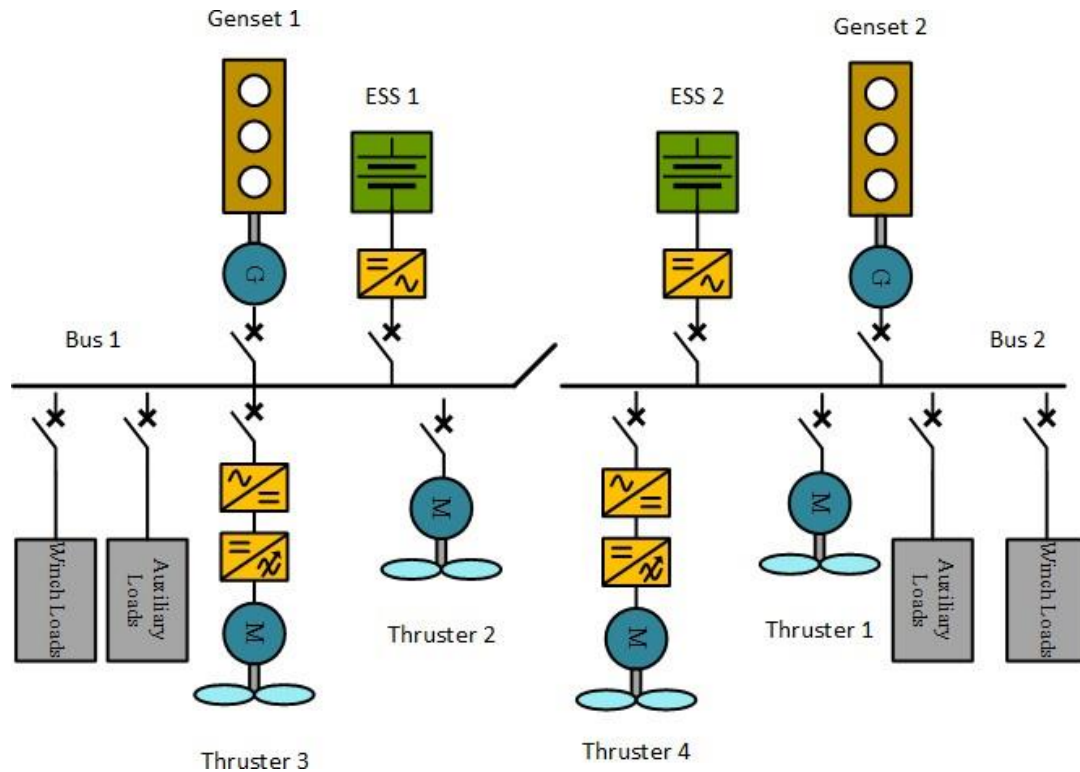

Figure 1: Power system overview of the studied vessel

The power system includes two main buses by the bus-tie breaker, with each bus is supplied by one main gensets, with nominal size of 3500kW. In addition, a Li-ion ESS is included into each main bus sections with a capacity of 800kWh. The bus sections supply power to two thrusters, the auxiliary machinery and the mission loads. The selected mission load is from winch including active heave compensation load during tensioning operations. Table 3 provides the ratings of all the components in the power system.

The load profile is mainly due to the thrusters in transit operation and from the winches during the handling and tensioning operations. The selected operational load profile is shown in Figure 2. represents the transit operation from port to field at the beginning and then winch operation in station-keeping mode. Thus, the conclusion drawn from this work could be generalized for this specific vessel type.

From the objective of the paper, an analysis on peak shaving function of ESS is simulated to determine the performance of the power system with actual load profile and including the distribution electrical losses. For estimation of consumed fuel oil consumption, the specific fuel oil consumption at different load steps for the selected engine is used as shown in Table 1.

The emissions are calculated based on Internationally approved conversion factor from IMO MEPC1/Circular. 684: 2009, ISO 8217 Grades DMX, IPCC 2006 guidelines

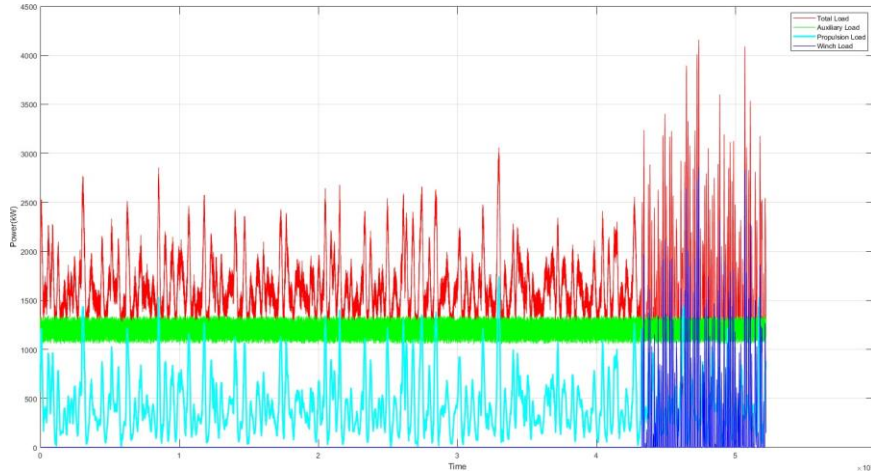

Figure 2: Load Profile of a vessel in study

Table 1: SFOC Table for selected Engine

Load (%)	SFOC (g/kWh)
25	231
50	187.95
75	189
85	190.05
100	193.2

(ISO, 2017). The Table 2 provides the emission conversion factor used in this work.

Table 2: Emission Factors

Emission	Emission Factor	Guideline Reference
CH4	0.3 (g CH4/Kg Fuel)	IPCC 2006
N2O	0.08 (g N2O/ Kg Fuel)	IPCC 2006
CO2	3206 (g CO2/ Kg Fuel)	ISO 8217 Grades DMX
NOx	72 (g NOx/ Kg Fuel)	IPCC
SOx	8 (g SOx/ Kg Fuel)	MEPC

Table 3: Rating and number units of components used in the power system

Components	Nominal size	Number of units
Genset	3500 kW	2
ESS	Q: 800kWh Charge Limit: 1600kW Discharge Limit: 2400kW	2
Winch	3000 kW	2
Tunnel Thruster	800 kW	2
Azimuth Thruster	1500 kW	2
Auxiliary Loads	1500kW	2

The load reference for the gensets and ESS are computed by a power management system (PMS) based on the system load. The Figure 3 illustrates on how the PMS decides the operation of the gensets and ESS in terms of starting/stopping gensets, adjusting the power reference. The amount of fuel consumed, and equivalent emissions are calculated based on the delivered power by the gensets according to the tables above.

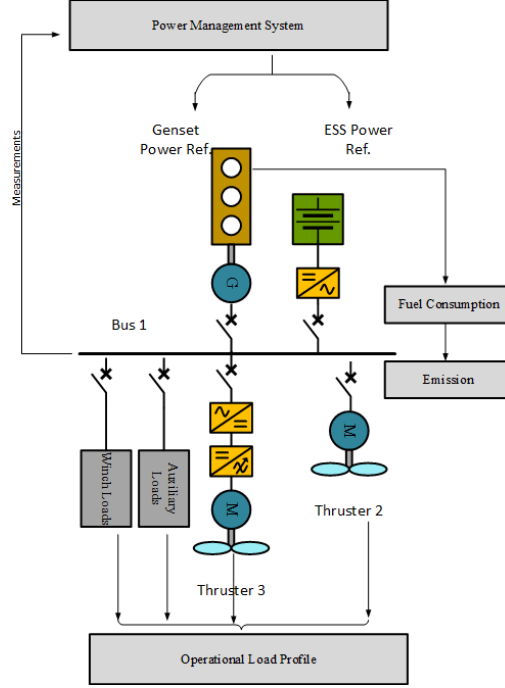

Figure 3: Overview on load distribution and Fuel Consumption calculation

The load profile in Figure 2 is for 87 minutes of operation with a sampling rate 10- samples per seconds.

3. Simulations and Model

The simulation is performed in MATLAB, where simplified models of the physical components in the selected power system are configured. The efficiency and loss profile each component is used to determine the gross load based on the load profile for the consumers and based on the power reference for the producers.

The SFOC data is selected for engine model 6L32D IMO Tier2 from Wartsila engine- configurator (Wartsila, 2021). The fuel consumption is computed for the entire simulation period using determined SFOC numbers based on the power delivered by the gensets. The fuel density is considered as 870 kg/m^3 . The genset efficiency is set to 98% when the load is above 70% of (maximum continuous rating) MCR and is set to 95% when the load is between 50 to 70% of MCR and 93% when the load is below 50% of MCR.

For ESS, a charge limit of 2C and discharge limit of 3C was applied. The initial State of Charge (SoC) for simulation is 80% and the SoC reference is 70%. The power loss during the charging and discharging process are accounted by configuring the drive efficiency as 95%. The SoC of the ESS is computed using below formula,

$$SoC(t) = SoC(t-1) + \eta_c C_p / Q - \eta_d D_p / Q \quad (1)$$

where, η_c is the charging efficiency, η_d is the discharging efficiency, C_p is the charging power, D_p is the discharging power and Q is the nominal energy of the ESS.

The simulation is carried out for almost 87 minutes of the operation for the complete

system as shown in Figure 1. Two different simulation cases are performed, conventional peak shaving and proposed long- and short-term peak shaving. The power system is configured as single bus section in both simulations.

In conventional peak shaving, the standby genset start limit is set to 50% of one genset MCR for than 30 seconds or if the ESS SoC is below 60% to charge the ESS. However, in the proposed peak shaving approach, the genset start limit is set to 70% of one genset MCR for than 30 seconds or if the ESS SoC is below the 60% to charge the ESS.

The latter approach allows the power system to run with one genset during the long- term peak power requirement from running heavy consumers and avoids load shedding of consumers during a short-term peak power.

In the model a simple PI controller is used for controlling the SoC of ESS in maintaining it around the SoC reference. In Figure 10, the ESS SoC profile with charging and discharging.

4. Results and Discussions

In this sections, the results from the simulation are analyzed and discussed. The load distribution between genset and ESS are shown in Figure 4. It can be observed, that in conventional peak shaving there are **2826** instances where second genset started. With this condition, the operator will always tend to run the second genset to avoid frequent start and stop. This will result in more fuel consumption, emission and increased total running hours.

The load variation in transit operation is small compared to winch operation. In transit operation, the thruster load contributes to small peaks which results in increasing the load on the genset for more than the defined start limit period. In winch operation, the load variation is extreme resulting in large peaks and continuous peak shaving by ESS to limit the load fluctuations on the gensets.

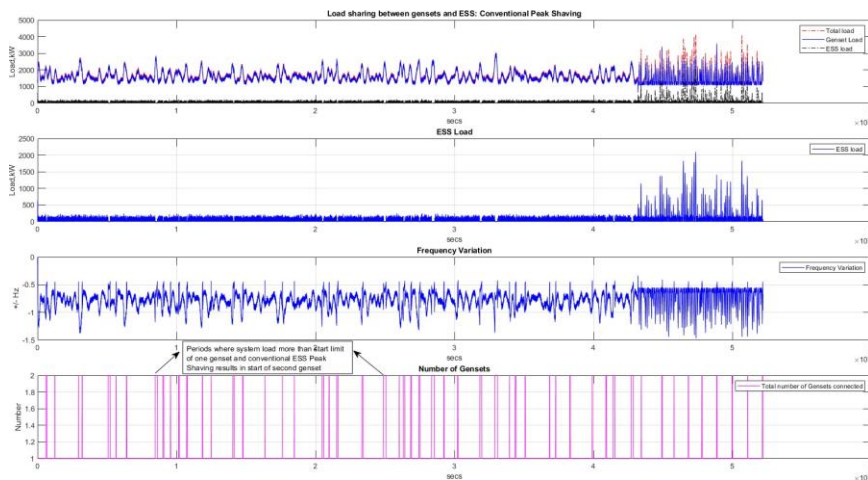

Figure 4: Load Profile with ESS in conventional peak shaving resulting in frequent start and stop of second genset

In Figure 6, the load profile for genset with ESS in long- and short-term peaks shaving is shown. With ESS contributing for both short-term (5 to 10 seconds peaks) and long- term (40 to 70 seconds peaks), the need for running second genset is minimal. It is only a total of two instances where the second genset gets a start request.

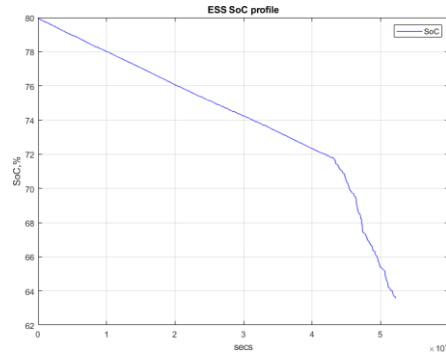

Figure 5: ESS SoC profile for conventional peak shaving

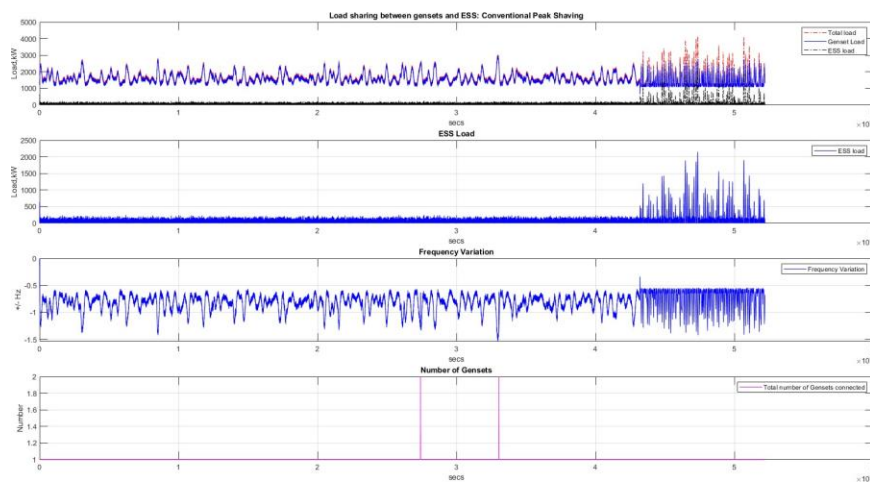

Figure 6: Load Profile with ESS in long- and short-term peak shaving resulting in less start and stop of second genset

In the winch operation, the long-term peak shaving helps to run the genset at stable load with ESS delivering the peak loads for longer periods. The ESS is operated little aggressively in this case compared to conventional peak shaving. However, the depth of discharge of ESS are within the acceptable limits of battery managementsystem.

Figure 8 and Figure 9, shows a selected section of the load profile illustrating the long-term and short-term peakshaving function of ESS.

The Table 4, provides the summary of total accumulated fuel consumption and equivalent CO₂ emissions for both cases. It is seen that the proposed peak shaving method results in a reduction of **1.6791 m³ (8.44%)** of fuel consumption and **4.6835 tonnes** of CO₂.

Similarly, the total fuel consumption and corresponding CO₂ emissions using the long- and short-term peak shaving is presented in Figure 10.

Table 4: Fuel Consumption and CO₂ Emission

Case	Fuel Consumption (m3)	CO2 Emission (tonnes)
Conventional ESS Peak Shaving	19.895	55.4915
Long-and Short-term Peak Shaving	18.2159	50.8080

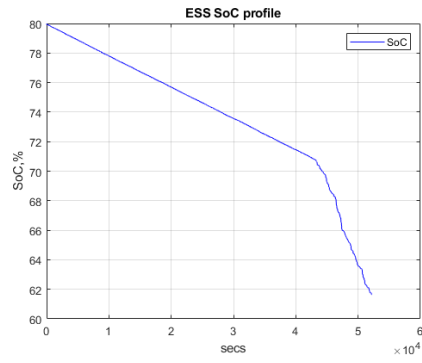

Figure 7: ESS SoC profile for long-and short- term peak shaving

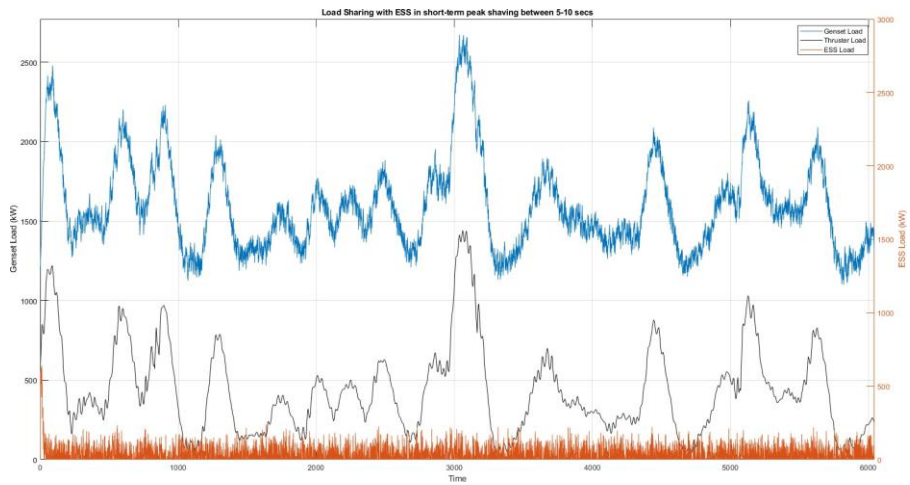

Figure 8: ESS load profile with genset in short-term peak shaving

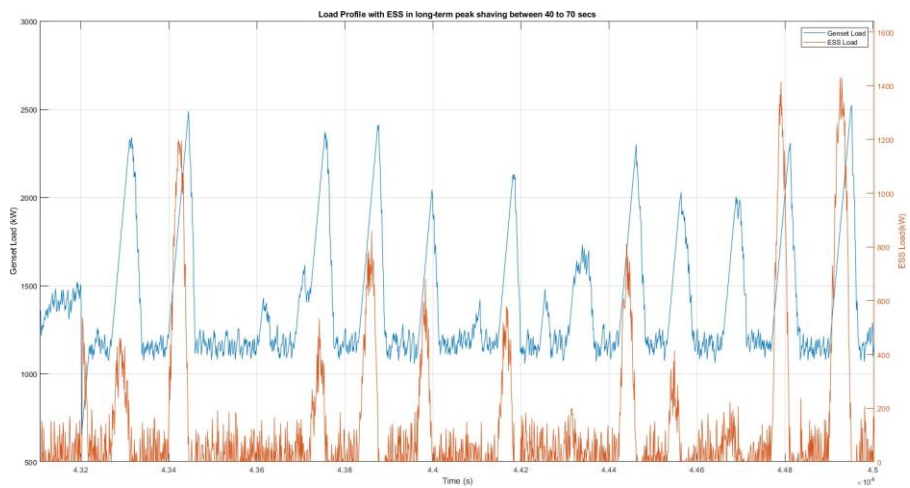

Figure 9: ESS load profile with genset in long-term peak shaving

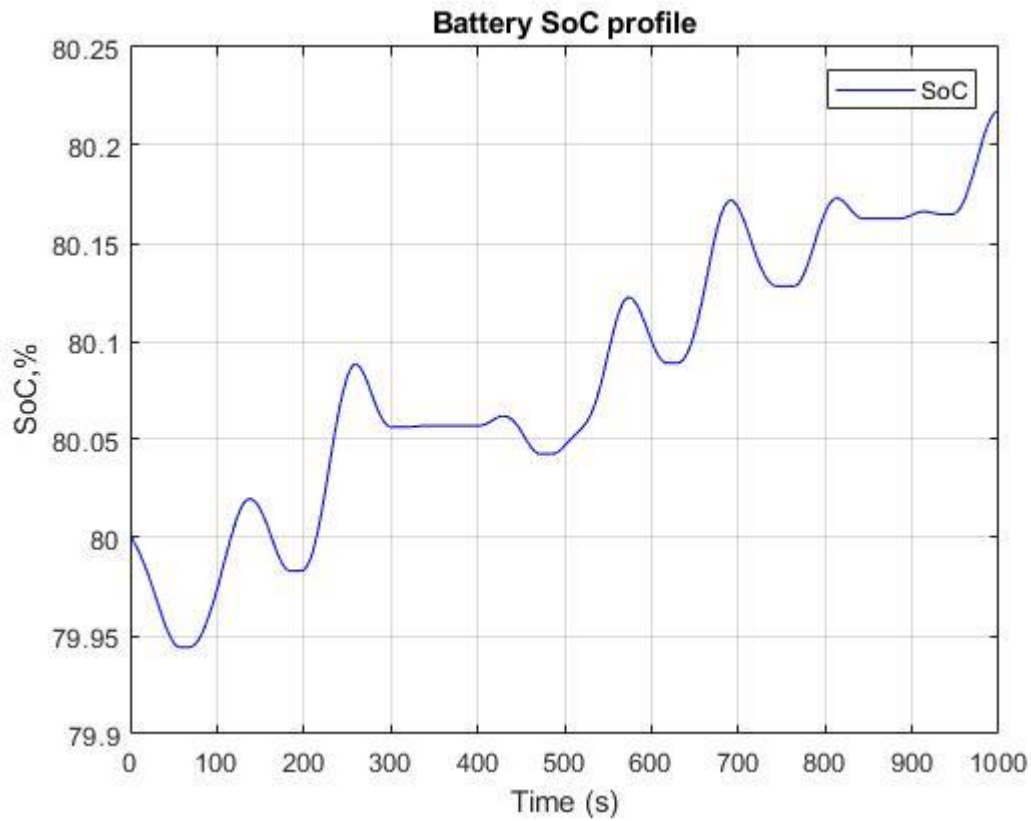

Figure 10 : Zoomed in ESS SoC profile with charge and discharge cycles

Based on (Wartsila, 2021), the estimated maintenance cost per hour for the selected genset is around 50 NOK/h or 5 USD/h. With the proposed approach, it is possible to reduce the running hours of genset by **0.0781** hours corresponding to **5.1%** reduction in cost.

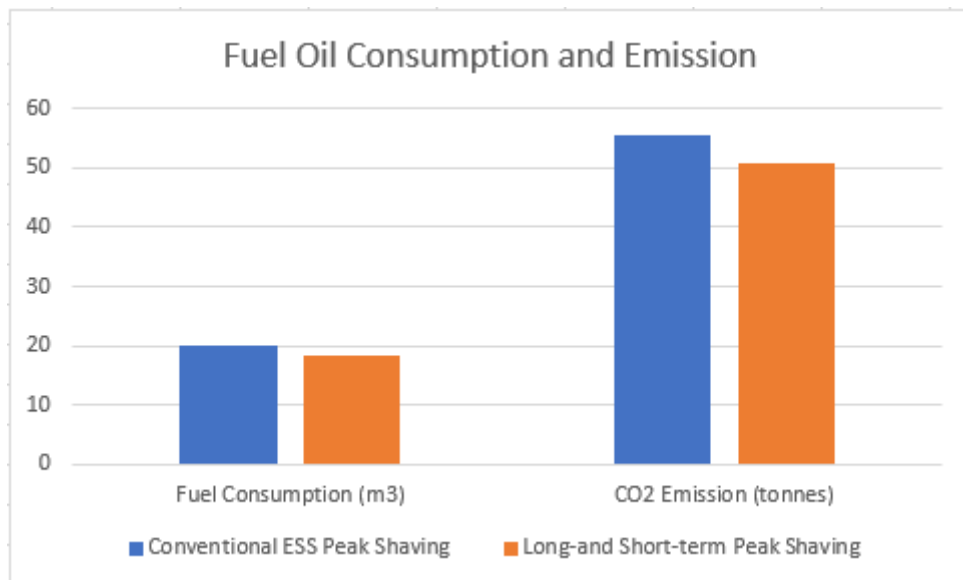

Figure 11: Total accumulated fuel consumption and CO₂ Emissions

Table 5. Total running and equivalent maintenance cost

Case	Total running hours	Equivalent Maintenance cost (USD)
Conventional ESS Peak Shaving	1.5284	7.64
Long-and Short-term Peak Shaving	1.4503	7.25

5. Conclusion

In this work, the load profile of a typical offshore support vessel is used to simulate the operation of a hybrid power system in both conventional and long- and short-term peak shaving. The load profile includes both transit and winch operation, considering thruster load, auxiliary load and winch load. The consumed fuel oil and equivalent CO₂ emissions are computed from the simulated results. From the results, it is observed that proposed peak shaving approach helps to achieve 8.44% reduction of fuel consumption and corresponding emissions and 5.10% reduction in maintenance cost for the operation of 1.45 hours. It is possible, by modifying the control methodology in PMS enabling running of ESS to support short peaks and long peaks enabling to run the genset at better utilization and eliminating the need for running the second genset. Moreover, the proposed framework can be useful in genset scheduling. The future work shall include analyze on ESS health during the mission operation.

Abbreviations

CII	Carbon Intensity Indicator
EEDI	Energy Efficiency Design Index
EEXI	Energy Efficiency Ship Index
ESS	Energy Storage System
IMO	International Maritime Organization
MCR	Maximum continuous rating
PMS	Power Management System
PI	Proportional Integral
SEEMP	Ship Efficiency Management Plan
SFOC	Specific Fuel Oil Consumption
SoC	State of Charge

References

IMO. IMO Resolution MEPC.203(62) Annex 19. 2011 July. Available from: [https://wwwcdn.imo.org/localresources/en/OurWork/Environment/Documents/Technical%20and%20Operational%20Measures/Resolution%20MEPC.203\(62\).pdf](https://wwwcdn.imo.org/localresources/en/OurWork/Environment/Documents/Technical%20and%20Operational%20Measures/Resolution%20MEPC.203(62).pdf).

IMO. Energy Efficient Ship Operation: Module 2 Ship Energy Efficiency Regulations and Related Guidelines. 2016 January. Available from: <https://wwwcdn.imo.org/localresources/en/OurWork/Environment/Documents/Air%20pollution/M2%20EE%20regulations%20and%20guidelines%20final.pdf>.

IMO. Guidelines for voluntary use of the ship energy efficiency operational indicator (EEOI) . 2009 August. Available from: <https://gmn.imo.org/wp-content/uploads/2017/05/Circ-684-EEOI-Guidelines.pdf>.

IMO. Further Shipping GHG emission reduction measures adopted. 2021 June. Available from: <https://www.imo.org/en/MediaCentre/PressBriefings/pages/MEPC76.aspx>.

Nielsen JB. Modeling and Simulation for Design Evaluation of Marine Machinery Systems. 2019 June.

DNV. Hybridization Pays. 2018 June. Available from: <https://www.dnv.com/expert-story/maritime-impact/Hybridization-pays.html>.

Lu Y. Optimal Scheduling and Loadsharing of a Hybrid Power Plant with Gensets and Battery Banks. 2019 June.

Adnanes AKA, Oslo M, Wolak B, et al. Design and Control System Status and Inventions in Electrical Power and Thruster Systems for Drillships and Semi-Submersible Rigs. Dynamic Positioning Conference. 2004;:1–15.

ISO. ISO 8217:2017 Petroleum Products- Fuels (class F)- Specifications of marine fuels . 2017 03. Available from: <https://www.iso.org/standard/64247.html>.

Solutions WM. Wartsila Engine Online Configurator. 2021. Available from: <https://www.wartsila.com/marine/engine-configurator>.