

Ammonia as an alternative fuel on mega-yacht: an analysis of case studies using different fuel cell technologies

R Russo*, PhD Student, MSc Chemical Eng, T Coppola, L Micoli

Industrial Engineering Department, University of Naples "Federico II", IT

* Corresponding Author. Email: roberta.russo5@unina.it

Synopsis

To meet the aim of emission reduction and decarbonization, the study of alternatives to traditional fuels and thermal machines is increasing, in favour of new technologies, such as Fuel Cells (FCs) and batteries, and the use of innovative fuels, such as methanol, hydrogen and ammonia. In this study, the possibility of using ammonia as a hydrogen carrier for FCs has been investigated. In particular, both direct ammonia-fueled FCs (SOFC, AFC) and indirectly fueled FCs (PEMFC) have been considered. The case study of a 64 m length mega-yacht has been considered and the effects of the installation on board of these new technologies on the general arrangements have been evaluated. Different power configurations are proposed to allow both a hybrid and fully electric propulsion to reach zero-emission conditions. A fuel control strategy is also proposed to support the wide load variation.

Keywords: Zero-emission ship; Fuel Cell application; Ammonia; Marine systems; Hybrid system propulsion.

1. Introduction

The reduction of the carbon footprint of maritime shipping is currently a debated topic and a primary goal (Cutting GHG emissions from shipping - 10 years of mandatory rules 2022). In the last decades, the International Maritime Organization (IMO) has targeted greenhouse gas (GHGs) emissions on ships introducing several regulations aiming for a 50% reduction in GHGs by 2050 up to a complete elimination in this century (McCarthy 2010, Mocerino *et al.* 2018). Several climate-friendly alternatives are being considered to reach that goal, these include both power energy technologies, such as Fuel Cells (FCs) and batteries, and innovative fuels, like hydrogen and methanol (Altosole *et al.* 2014, Bouman *et al.* 2017, Anders 2019, Ming Main Author *et al.* 2020). Ammonia has recently attracted wide interest as fuel for shipping (Hansson *et al.* 2020, Kim *et al.* 2020). Nowadays, ammonia is primarily used to produce fertilizers and other chemicals rather than for energetic purposes. Nevertheless, in the future, there is potential for climate-friendlier production processes. Green ammonia can be synthesized by using green hydrogen coming from renewable or non-carbon sources, like wind or solar energy, and the so-called blue ammonia can be produced by reducing the emission footprint of the production using carbon capture technologies (MacFarlane *et al.* 2020, Cesaro *et al.* 2021, Ghavam *et al.* 2021). Ammonia certainly has the energy potential as alternative marine fuel: it's abundant and common, and it has an energy density of around 3 kWh/l (liquid, 25 °C), which is lower than the energy density of Marine Gas Oil (MGO) (\approx 9.9 kWh/l) but it does not have to be stored in high-pressure tanks or cryogenic dewars (unlike hydrogen and Liquefied Natural Gas (LNG)) (Elishav *et al.* 2021). The most relevant advantage of using ammonia in the marine sectors is that it does not release CO₂ and other harmful compounds, such as Sulphur Oxides (SO_x) and Particulate Matter (PM), allowing it to comply with stringent environmental regulations (Hansson *et al.* 2020, Kim *et al.* 2020, Gallucci 2021).

Ship-owners and industry analysts state that ammonia will play a pivotal role in decarbonizing ships, according to a DNV's report (2019), ammonia could make up 25 % of the maritime fuel mix by 2050, with nearly all newly built ships running on ammonia from 2044 onward (DNV-GL 2020). However, the application of ammonia in the marine transportation sector is still in the early stages: no vessels of any size today are equipped to use this fuel. Even if they were, the supply chain of green ammonia is almost virtually non-existent (MacFarlane *et al.* 2020). As green ammonia slowly scales up, the shipping industry will have to solve some other issues related to toxicity, corrosiveness, slow ignition and Nitrogen Oxides (NO_x) emissions (Kobayashi *et al.* 2019, Elishav *et al.* 2021). Moreover, since ammonia's energy density is about half that of diesel, if it is used as a direct fuel in ICE, ships will need to accommodate larger storage tanks or reduce the operating range of vessels. Nevertheless, burning ammonia in ICE produces NO_x which contributes to smog, acid rains and can harm people (Kobayashi *et al.* 2019). Combustion also yields small amounts of nitrous oxide (N₂O) is a GHG

Author's Biography

Roberta Russo is a P.h.D student at the Industrial Engineering Department, University of Naples "Federico II" in Naples, IT. She is a Chemical Engineer with a background in renewable energies, fuel cells, emissions abatement systems.

significantly more dangerous than CO₂. Therefore, shipbuilders have to consider special equipment to install on board to avoid such outcomes, e.g. a selective catalytic reduction system (SCR) (Ruggiero 2020). An option to prevent air pollution with ammonia is to use the FCs technology instead of ICEs (Cheddie 2012, Afif *et al.* 2016, Van Biert *et al.* 2016, Siddiqui and Dincer 2018, Micoli *et al.* 2021). An FC is an electrochemical device that converts the chemical energy of a fuel directly into electrical energy with an efficiency higher than ICEs. Since no combustion process occurs in an FC, the release of harmful gases or particles in the air is avoided (Moseley 2001, Coralli *et al.* 2018). According to these statements, the present work investigates the possibility of installing ammonia FCs on board an existing mega-yacht aiming to supply the hotel loads and support the propulsion in different operating conditions. It is supposed that this new power generating system will work as an auxiliary unit which should allow to reach zero-emission conditions and navigation in Emission Control Areas (ECA). A comparison has been made between three different FC technologies: Proton Exchange Membrane Fuel Cell (PEMFC), Solid Oxide Fuel Cell (SOFC) and Alkaline Fuel Cell (AFC). The work investigates from a conceptual design point of view the introduction of new technology on board the ship. It aims to point out the major constraints in terms of footprint, weights and achievable autonomy considering the original design of the ship. To the knowledge of the authors, almost no studies in the literature have been found carrying out such a kind of analysis. The mega-yacht is an interesting application for these technologies because it could favour a market in which passengers are allowed to enjoy a virtually silent and clean yachting experience. The construction of yachts had an impressive growth in the last decades reaching an industrial production scale, therefore they cannot be considered “private ships” anymore and have to be developed accordingly to commercial passenger ships rules (e.g. MARPOL). This means that yachts have to abide by environmental rules as well (Ruggiero 2020).

2. Methods

2.1. Fuel Cell Systems

FC technologies considered in the present work are PEMFC, SOFC, AFC. Ammonia can be fed to the SOFC and AFC directly, while to PEMFC is used as a hydrogen carrier (Cheddie 2012, Siddiqui and Dincer 2018). In the latter case, ammonia is dissociated easily into nitrogen (N₂) and hydrogen (H₂) through an endothermic reaction, then the produced hydrogen is concentrated before feeding an FC. For all cases under consideration, the flow rate of fuel to be treated has been estimated using relation (1), assuming that the electrical efficiency (η) is constant:

$$m = \frac{P}{\eta LHV} \quad (1)$$

Where P is the power generated, LHV is the lower heating value of hydrogen (120 MJ/kg) or ammonia (18.48 MJ/kg).

Proton Exchange Membrane Fuel Cells (PEMFCs) use a polymer membrane with high proton conductivity as an electrolyte and operate at temperatures between 70 and 100 °C; they are mainly developed for automotive and small-scale power generation (1-250 kW) applications. The product FCgen®-HPS provided by Ballard (Canada) has been assumed as a reference (Ballard website 2022), which operates at about 80 °C. This PEM module provides 140 kW power with an electrical efficiency of 55%. A basic working scheme is shown in Figure 1 and other main characteristics are reported in Table 1 (Breeze and Breeze 2019). The characteristic reactions at the anode, cathode and overall reaction are:

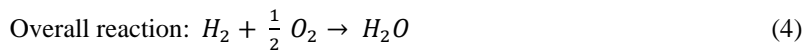
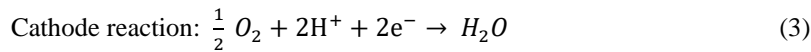
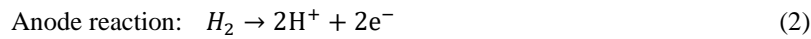

The pure hydrogen required for fuelling the PEM is supposed to be produced through an ammonia decomposition and purification system, which constitutes the ammonia processing system (AP). The ammonia is taken from the tanks, preheated in a heat exchanger (for better energy efficiency), vaporised and then separated in the main reactor. In this study, we referred to the specifics and performance of the reactor supplied by the SinceGas company (China), which can process an NH₃ flow rate up to 250 Nm³/h. Within the reactor, ammonia can be dissociated into H₂ and N₂ via the endothermic reaction:



This reaction requires both a catalyst and a heat source, which is supposed to be produced electrically on board. Then, a Pressure Swing Adsorption (PSA) system, which generally uses special molecular sieves, is required for the separation of H_2 from N_2 . Specifically, the PSA returns a quantity of pure hydrogen of about 15 kg/h. The overall efficiency is about 88%, considering the 98% efficiency of the decomposition reactor and the 90% of the PSA system (SinceGas website 2022). APS requires about 150 kW of electric power from the main switchboard, consequently, the electrical balance has been adjusted accordingly.

Solide Oxide Fuel Cells (SOFCs) operate at high temperatures (in the range of 700-1000 °C) to ensure high conductivity to the electrolyte, which consists of ceramic materials (zirconium oxide doped with yttrium oxide) (McPhail *et al.* 2017). SOFCs can be divided into two categories depending on the chemical specifics of the electrolyte. In the present study, it is considered a basic electrolyte, which conducts O^{2-} ions. They are particularly promising for stationary power generation and cogeneration in power ratings from a few kW to several tens of MW. The product ‘‘SOFC BOL module’’ provided by Bloom Energy company (USA) has been selected as a reference. This module has an output power of 350 kW and an electrical efficiency of 55%; other specifics are reported in Table 1 and a basic working scheme is shown in Figure 1. The overall and the electrodes’ reactions are (Breeze and Breeze 2019):

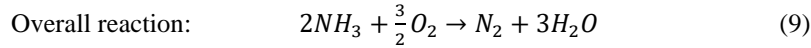
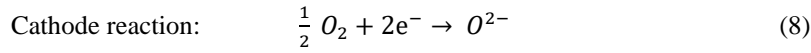
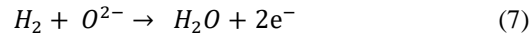
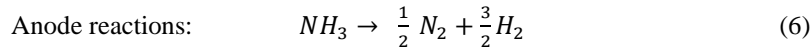

Alkaline Fuel Cells (AFCs) use an electrolyte consisting of a water solution of potassium hydroxide (≈ 30 % w/w) and operate at temperatures of about 120 °C (Coralli *et al.* 2018, Breeze and Breeze 2019), the working scheme is shown in Figure 1. They have reached a good degree of technological maturity, especially for military and space applications due to their high electrical efficiency and reliability; despite this, the low energy density and the request for pure feed gases have severely limited their diffusion. The 350 kW HydroX-Cell(L) product from the AFC energy company (UK) is taken into account in this study. It has an electrical efficiency of 60% and other specifics are reported in Table 1. The overall and the electrodes’ reactions are (Coralli *et al.* 2018, Breeze and Breeze 2019):

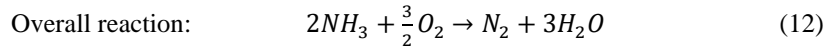
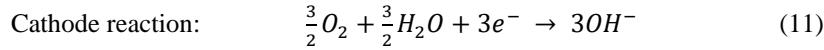
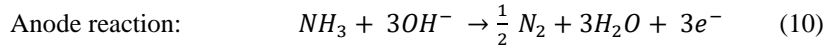

Table 1: Main specifics of the selected FC and AP power system

Specific	AP	PEM	SOFC	AFC
Inlet	NH_3	H_2	NH_3	NH_3
Operating temperature [°C]	100-300	70-80	700	120
Power [kW]	600	140	350	350
Efficiency [%]	88	55	55	60
Weight [kg]	47	55	18433	17500
Volume [m ³]	14	0.1	33	67

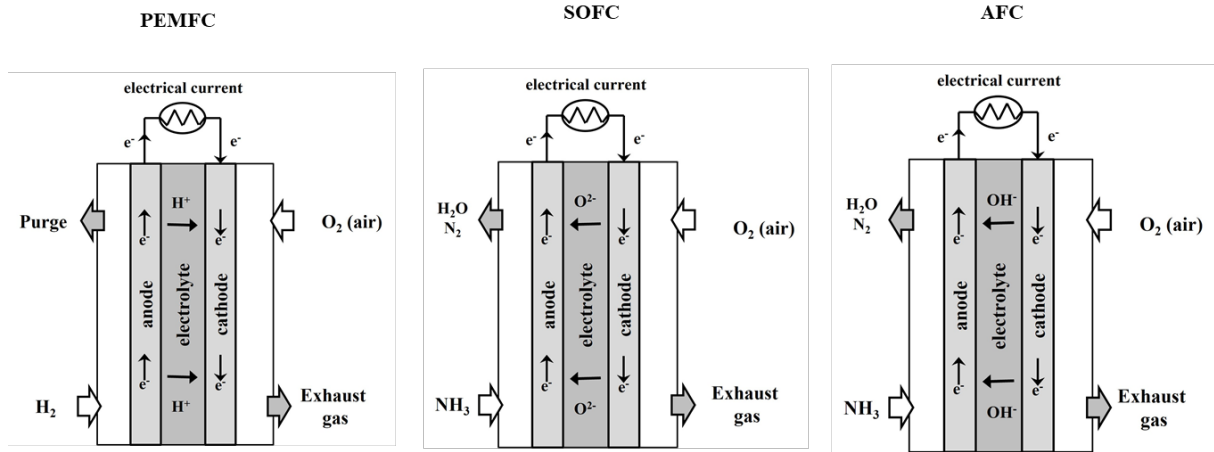

Figure 1: PEMFC, SOFC and AFC working schemes

2.2. Control strategy

Ammonia-fuelled FCs installed on board a mega-yacht requires a well-defined control system allowing an adequate response to the widely load variations and ensuring high performance of the system. Different systems (i.e. model-based control, feedback control, nonlinear control, etc.) can be used to improve control accuracy and dynamic performance depending on the load variations (Bao *et al.* 2006, Das *et al.* 2017, Ziogou *et al.* 2018, Bizon 2019). In general, the performance of any fuel economy strategy is dictated by the real-time operation of the power generator system under load perturbations and constraints related to FC system dynamics (Sapra *et al.* 2020).

As a response to a change in the fueling inputs, the power generated by the FC system appears with some delay due to the time constants that model the dynamic part of the overall system [(Ahmadi *et al.* 2018), the limited slopes used by the fueling regulators to change the flow rates (Das *et al.* 2017), the response time of the control and optimization loops etc. (Bizon 2019, Guo *et al.* 2019).

So, it is suggested to use a real-time strategy in order not to affect the time delay already given by the dynamic operation of the FC system under required regimes (Bizon *et al.* 2018). Therefore, a fuel supply control system could be a promising strategy for the FC systems proposed, according to literature results (Bizon *et al.* 2018, Bizon 2019).

A fuel supply control system mainly consists of valves, circulation pumps, controllers and pressure sensors of the fuel flow. In PEMFC systems, controllers regulate the flow and pressure of hydrogen by handling the opening of recirculating valves and pumps (Figure 2). The main objective of controlling hydrogen fuel systems is to regulate both the flow and the pressure of hydrogen, through the system valves, to meet the operational requirements of PEMFC systems, in which, the control performance (dynamic and static) affects output power and operational performance. In the case of AFC and SOFC, the control systems are similar to that of a PEM since ammonia is fed at the gaseous phase like hydrogen (Haseltalab *et al.* 2020).

According to Abbaspour *et al.* a robust adaptive control approach of a neural network can be proposed to stabilize the hydrogen pressure in PEMFC systems and improve the response speed (Abbaspour *et al.* 2016). In addition, control procedures of hydrogen fuel systems in dead-end or flow-through mode can be optimized to improve the way the anode works on stack efficiency and lifetime. To improve the control performance of the hydrogen supply, various controls are proposed, including robust control, LQG control and predictive control of the model depending on the non-linear characteristics and the different operating conditions of the PEMFC systems (Bao *et al.* 2006, Rabbani and Rokni 2013, Abbaspour *et al.* 2016).

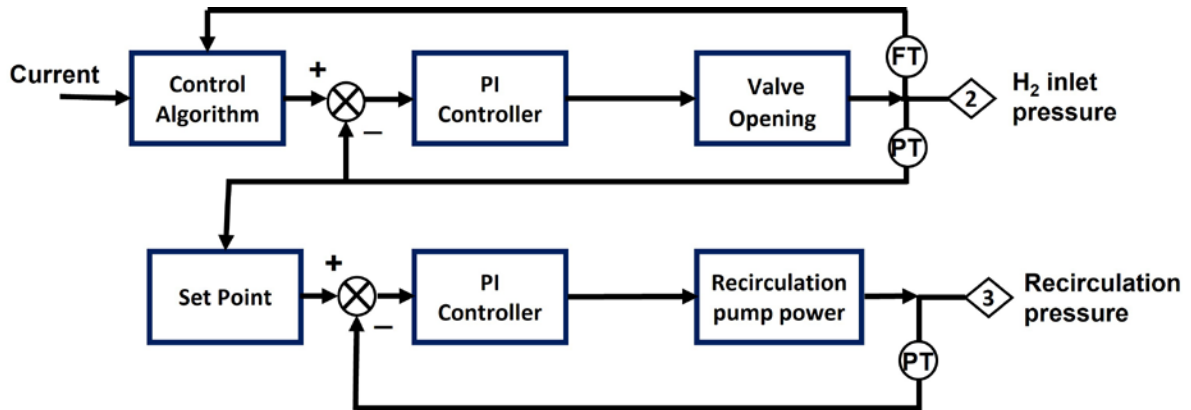

Figure 2 - Hydrogen supply control systems scheme (Rabbani and Rokni 2013).

3. Case study

It has been considered a case study ship to investigate the impact on the general arrangements introducing ammonia-powered fuel cell systems on board maintaining the original power generating systems. The target ship is a mega-yacht with a length of about 64 m, which has an Atlantic autonomy of 4000 nm at 14 kn and reaches a maximum speed of 18 kn. Shipowners generally establish the main requirements of the ship, i.e. the number of passengers and crew, size of cabins, public spaces, and speed. These and other general characteristics of the mega-yacht are reported in Table 2.

Table 2: General specifications of the mega-yacht

Main dimension LxBxH [m]	64.4x11.3x6.2
Displacement [t]	921
Full load immersion [m]	3.6
Decks [num]	4
Passengers [num]	12
Crew members [num]	10
Cruise speed [kn]	14
Maximum speed [kn]	18
Autonomy [day]	14
Propulsion Diesel engine (×2) [kW]	1320
Shaft Generator engine (×2) [kW]	260
Gen-set [kW]	575

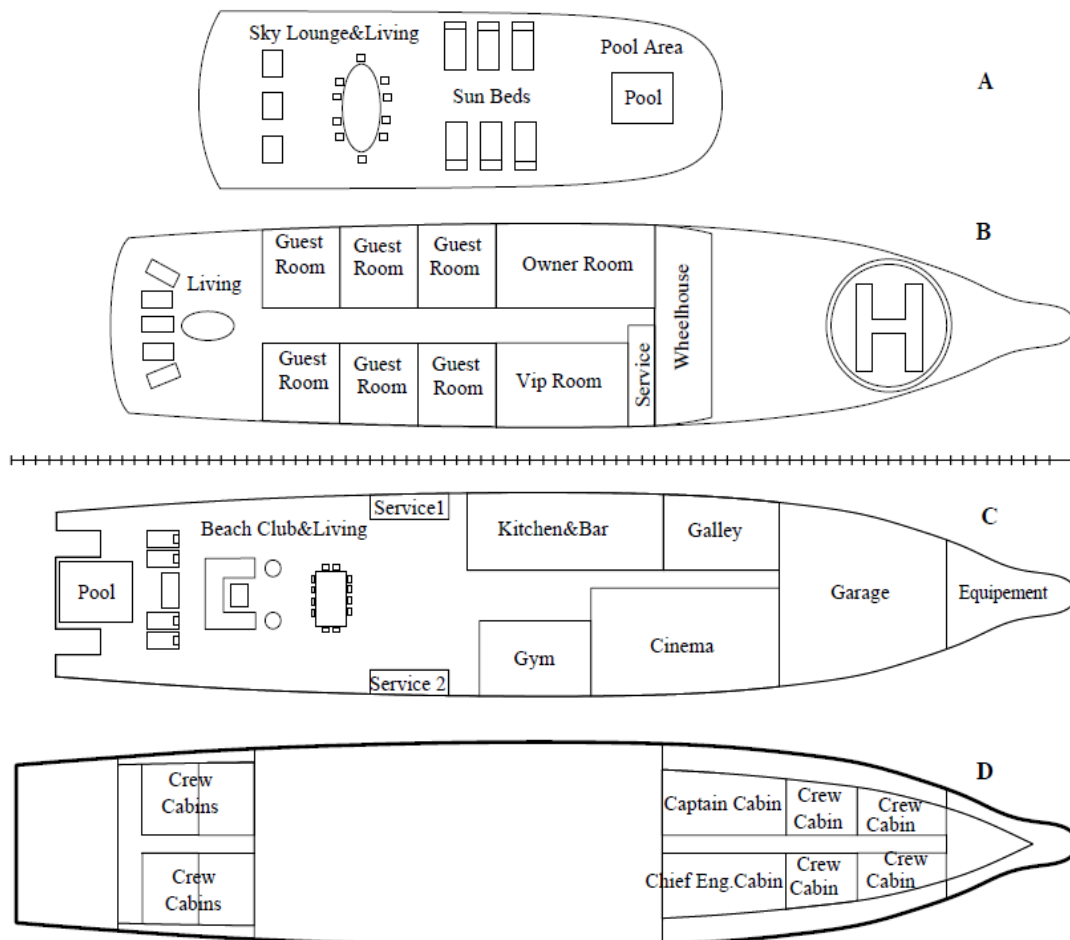

Figure 3: The layout of the mega-yacht: A: Sun Deck (12.9 m above BL); B: Upper Deck (9.2 m above BL); C: Main Deck (6.2 m above BL); D: Lower Deck (3.3 m above BL)

The ship's structure is laid out over four decks, as shown in Figure 3. The engine room is placed between the Base Line (BL) and the Main Deck (from the 17th to the 50th frames), while the fuel is stored between bulkhead 4th and the collision bulkhead. The initial configuration of the mega yacht includes two main Diesel engines (1320 kW Rolls Royce, model 4-stroke MTU 12V 4000 M33F) capable of supplying a maximum power of about 3021 kW to reach 18 kn. Additionally, it is considered the installation of two liquid-cooled permanent magnet synchronous motor shaft generators directly connected to the gearboxes (Type C SISHIP EcoProp from Siemens) to recover the engines' waste energy and to provide additional power to the propeller when the main engine is underperforming. This configuration allows both the "Power Take In" (PTI) and "Power Take-Off" (PTO) modes for energy transmission (The Superyacht Directory | Superyacht Database 2022). A Diesel Gen-set (MTU 12V 2000 M41A by Rolls Royce) provides the non-propulsion power demand, with a power output of 575 kW at 1500 rpm.

4. Results

The onboard installation of FCs has a different arrangement for the three technologies under consideration, depending on the volume and weight of the FC system. PEMFCs are installed in a different area than the AP, though the footprint is limited, it can be arranged in a separate enclosed space within the engine room. The AP is arranged between the 3rd and 4th bulkheads. These rooms are classified as Hazardous Area Zone 1; therefore, a dedicated ventilation system and airlocks are provided.

SOFc and AFC have a very similar onboard layout: the FC space is larger than the case of PEMFC, which is due to the higher footprint. These are arranged between the 3rd and 4th bulkheads and enclosed by airlocks. The described arrangements are shown in Figure 4.

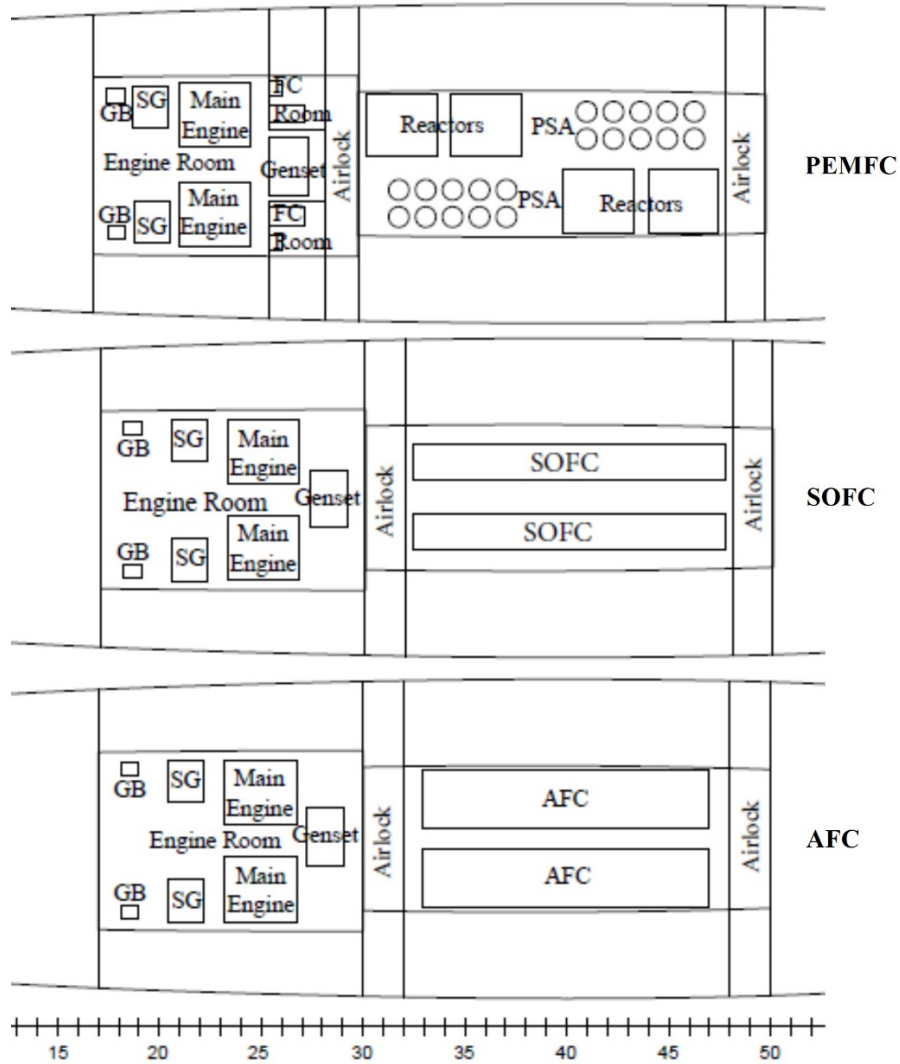

Figure 4: PEMFC, SOFC and AFC systems arrangement (GB: Gear Box, SG: Shaft Generator, FC: Fuel Cell, PSA: Pressure Swing Adsorption)

Ammonia is supposed to be stored onboard in the liquid state at 98 kPa and 240 K. According to the international rules (IMO 2016), ammonia cannot be contained in structural tanks but in type C double-walled tanks. Cemin Eurotank (Italy) tanks are chosen as a reference for the study, these have an external diameter of 980 mm, an internal diameter of 950 mm and are specifically sized accordingly to the available space. It results that 48 m³ of ammonia can be stored in nine tanks with the main specifics reported in Table 3 and arranged on board as shown in Figure 5.

Table 3: Main specifics of NH₃ storage tanks

Tanks	Volume	Length	Weight (empty)
[num]	[m ³]	[m]	[t]
6	5.0	6.8	1.2
3	6.0	8.5	1.5

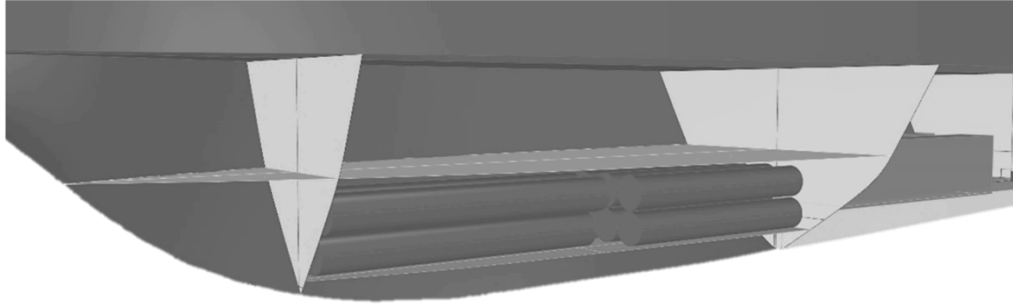

Figure 5: Ammonia storage tanks arrangement

The available volume for the storage tanks limited the amount of ammonia stored onboard, this affects considerably the autonomy of the ship depending on the FC and operating mode. In the case that the FC system supplies only the hotel loads (kitchen, lighting, air conditioning, rooms and deck), the autonomy is 6 days for PEMFC, 13 days for SOFC and 14 days for AFC. It must be noted that the lowest value for the PEMFC is due to the additional power required by AP.

The zero-emission condition can be achieved by FCs powering both the propulsion and the hotel load during the navigation and mooring in ports. In this case, the autonomy is approximatively the same for SOFC and AFC, while for the PEMFC is only 3 days. If it is assumed that the zero-emission condition is limited to 250 nm at 8 kn, allowing entry and exit in ECA areas and anchoring in ports, the autonomy is 4 days for PEMFC, 11 days for SOFC and 12 days for AFC. The calculated autonomies are summarized in Table 4.

Table 4: Autonomy for different conditions and FCs

Condition	Autonomy [days]		
	PEMFC	SOFC	AFC
Hotel loads	6	13	14
Zero Emission	3	6	6
Zero Emission @ 8 kn, 250 nm	4	11	12

5. Conclusions

This work investigates the application of different ammonia-fuelled FC technologies (PEMFC, SOFC and AFC) for electric power generation and to reach the zero-emission condition. A 64 m length mega-yacht is assumed as a case study. To identify the optimal solution, a comparison was carried out in terms of both the effects on the general arrangement and autonomy of the ship.

It resulted that, PEMFC is the most commercialized FC technology with the highest power density, but it requires a bulky and heavy AP system to produce pure H₂. SOFC and AFC can be directly fuelled by ammonia, on the other hand, they required a significant space onboard for the installation due to a low power density.

The zero-emission condition can be reached with all the FC configurations, but the limited ammonia volume stored affected the ship's autonomy. The autonomy is in the range of 3-4 days in the case of PEMFC and 6-12 days in the case of SOFC and AFC. Allocating more spaces onboard to the ammonia storage tanks can increase the autonomy, but it requires fundamental modification of the original arrangement of the ship.

Introducing ammonia-fuel cell technologies on board as an auxiliary power unit, to assist both the propulsion and the hotel loads, imply significant variation to the original distribution of spaces, weights and power management and distribution; therefore, these issues must be investigated in successive works. However, the installation of these technologies on board ships seems to be technically feasible, showing potential in terms of emissions reduction.

References

- Abbaspour, A., Khalilnejad, A., and Chen, Z., 2016. Robust adaptive neural network control for PEM fuel cell. *International Journal of Hydrogen Energy*, 41 (44), 20385–20395.
- Afif, A., Radenahmad, N., Cheok, Q., Shams, S., Kim, J.H., and Azad, A.K., 2016. Ammonia-fed fuel cells: a comprehensive review. *Renewable and Sustainable Energy Reviews*, 60, 822–835.

- Ahmadi, S., Bathaee, S.M.T., and Hosseinpour, A.H., 2018. Improving fuel economy and performance of a fuel-cell hybrid electric vehicle (fuel-cell, battery, and ultra-capacitor) using optimized energy management strategy. *Energy Conversion and Management*, 160, 74–84.
- Altosole, M., Buglioni, G., and Figari, M., 2014. Alternative Propulsion Technologies for Fishing Vessels: a Case Study. *undefined*, 8 (2), 296–301.
- Anders, J., 2019. Comparison of Alternative Marine Fuels SEA\LNG Ltd.
- Ballard website, 2022. FCgen HPS Spec Sheet [online]. Available from: https://www.ballard.com/about-ballard/publication_library/product-specification-sheets/fcgen-hps-spec-sheet [Accessed 24 Feb 2022].
- Bao, C., Ouyang, M., and Yi, B., 2006. Modeling and control of air stream and hydrogen flow with recirculation in a PEM fuel cell system—II. Linear and adaptive nonlinear control. *International Journal of Hydrogen Energy*, 31 (13), 1897–1913.
- Bizon, N., 2019. Sensitivity analysis of the fuel economy strategy based on load-following control of the fuel cell hybrid power system. *Energy Conversion and Management*, 199, 111946.
- Bizon, N., Iana, G., Kurt, E., Thounthong, P., Oproescu, M., Culcer, M., and Iliescu, M., 2018. Air Flow Real-time Optimization Strategy for Fuel Cell Hybrid Power Sources with Fuel Flow Based on Load-following. *Fuel Cells*, 18 (6), 809–823.
- Bouman, E.A., Lindstad, E., Riialand, A.I., and Strømman, A.H., 2017. State-of-the-art technologies, measures, and potential for reducing GHG emissions from shipping – A review. *Transportation Research Part D: Transport and Environment*.
- Breeze, P. and Breeze, P., 2019. Chapter 7 – Fuel Cells. *Power Generation Technologies*.
- Cesaro, Z., Thatcher, J., and Bañares-Alcántara, R., 2021. Techno-Economic Aspects of the Use of Ammonia as Energy Vector. *Techno-Economic Challenges of Green Ammonia as an Energy Vector*, 209–219.
- Cheddie, D., 2012. Ammonia as a Hydrogen Source for Fuel Cells: A Review. *Hydrogen Energy - Challenges and Perspectives*.
- Coralli, A., Sarruf, B.J.M., De Miranda, P.E. V., Osmieri, L., Specchia, S., and Minh, N.Q., 2018. Fuel cells. In: *Science and Engineering of Hydrogen-Based Energy Technologies: Hydrogen Production and Practical Applications in Energy Generation*.
- Cutting GHG emissions from shipping - 10 years of mandatory rules [online], 2022. Available from: <https://www.imo.org/en/MediaCentre/PressBriefings/pages/DecadeOfGHGAction.aspx> [Accessed 1 Feb 2022].
- Das, V., Padmanaban, S., Venkitesamy, K., Selvamuthukumar, R., Blaabjerg, F., and Siano, P., 2017. Recent advances and challenges of fuel cell based power system architectures and control – A review. *Renewable and Sustainable Energy Reviews*, 73, 10–18.
- DNV-GL, 2020. Ammonia as a marine fuel DNV [online]. Available from: <https://www.dnv.com/Publications/ammonia-as-a-marine-fuel-191385> [Accessed 1 Feb 2022].
- Elishav, O., Mosevitzky Lis, B., Valera-Medina, A., and Grader, G.S., 2021. Storage and Distribution of Ammonia. *Techno-Economic Challenges of Green Ammonia as an Energy Vector*, 85–103.
- Gallucci, M., 2021. The ammonia solution: Ammonia engines and fuel cells in cargo ships could slash their carbon emissions. *IEEE Spectrum*, 58 (3), 44–50.
- Ghavam, S., Vahdati, M., Wilson, I.A.G., and Styring, P., 2021. Sustainable Ammonia Production Processes. *Frontiers in Energy Research*, 9.
- Guo, C., Lu, J., Tian, Z., Guo, W., and Darvishan, A., 2019. Optimization of critical parameters of PEM fuel cell using TLBO-DE based on Elman neural network. *Energy Conversion and Management*, 183, 149–158.
- Hansson, J., Brynolf, S., Fridell, E., and Lehtveer, M., 2020. The potential role of ammonia as marine fuel-based on energy systems modeling and multi-criteria decision analysis. *Sustainability (Switzerland)*, 12 (8).
- Haseltalab A., 2020. Energy management for hybrid power generation using solid oxide fuel cell, in: conference proceedings of iSCSS.
- IMO, 2016. the International Code of Safety for Ships Using Gases or Other Low-Flashpoint Fuels (Igf Code). *Imo*.
- Kim, K., Roh, G., Kim, W., and Chun, K., 2020. A Preliminary Study on an Alternative Ship Propulsion System Fueled by Ammonia: Environmental and Economic Assessments. *Journal of Marine Science and Engineering 2020, Vol. 8, Page 183*, 8 (3), 183.
- Kobayashi, H., Hayakawa, A., Somarathne, K.D.K.A., and Okafor, E.C., 2019. Science and technology of ammonia combustion. *Proceedings of the Combustion Institute*, 37 (1), 109–133.
- MacFarlane, D.R., Cherepanov, P. v., Choi, J., Suryanto, B.H.R., Hodgetts, R.Y., Bakker, J.M., Ferrero Vallana, F.M., and Simonov, A.N., 2020. A Roadmap to the Ammonia Economy. *Joule*, 4 (6), 1186–1205.
- McCarthy, J.E., 2010. Air pollution and greenhouse gas emissions from ships. In: *Air Pollution and Ship Emissions*.

- McPhail, S.J., Conti, B., and Kiviaho, J., 2017. *The Yellow Pages of SOFC Technology - International Status of SOFC deployment 2017*. Enea (Italian National Agency for New Technologies, Energy and Sustainable Economic Development).
- Micoli, L., Coppola, T., and Turco, M., 2021. A Case Study of a Solid Oxide Fuel Cell Plant on Board a Cruise Ship. *Journal of Marine Science and Application*, 20 (3), 524–533.
- Ming Main Author, L., Ming, L., Chen, L., and Siu Lee Jasmine Sze Jia Yin Koh Eng Kiong Yang Mengyao Gou Xueni, L., 2020. Methanol as a Marine Fuel-Availability and Sea Trial Considerations Alternative Fuels for International Shipping A Study on the Future Energy Options of Singapore Harbour Craft Electrification of Singapore Harbour Craft-Shore and Vessel Power System Considerations Executive Summary.
- Mocerino, L., Quaranta, F., and Rizzuto, E., 2018. Climate changes and maritime transportation: A state of the art. *Technology and Science for the Ships of the Future - Proceedings of NAV 2018: 19th International Conference on Ship and Maritime Research*, 1005–1013.
- Moseley, P.T., 2001. Fuel Cell Systems Explained. *Journal of Power Sources*.
- Rabbani, A. and Rokni, M., 2013. Effect of nitrogen crossover on purging strategy in PEM fuel cell systems. *Applied Energy*, 111, 1061–1070.
- Ruggiero, V., 2020. ScienceDirect Peer-review under responsibility of the scientific committee of the International Conference on Industry 4.0 and Smart Manufacturing.-NC-ND license (<http://creativecommons.org/licenses/by-nc-nd/4.0/>) Peer-review under responsibility of the s.
- Sapra H., 2020. Potential of combined drive of fuel cell and internal combustion engine (COFAICE) for naval ships, in: conference proceedings of iSCSS.
- Siddiqui, O. and Dincer, I., 2018. A review and comparative assessment of direct ammonia fuel cells. *Thermal Science and Engineering Progress*, 5, 568–578.
- SinceGas, 2022. <https://www.sincegas.com/products.php>
- The Superyacht Directory | Superyacht Database [online], 2022. Available from: <https://www.boatinternational.com/yachts/the-superyacht-directory> [Accessed 24 Feb 2022].
- van Biert, L., 2016. A review of fuel cell systems for maritime application, in: *Journal of Power Sources* 327.
- Ziogou, C., Voutetakis, S., Georgiadis, M.C., and Papadopoulou, S., 2018. Model predictive control (MPC) strategies for PEM fuel cell systems – A comparative experimental demonstration. *Chemical Engineering Research and Design*, 131, 656–670.