

TRANSMISSION DESIGN FOR NAVAL WARSHIPS

BY

G. B. BEALE, M.ENG., C.ENG., M.I.MECH.E., R.N.E.S., and
LIEUTENANT-COMMANDER B. J. MCD. GOWANS, R.N., C.ENG., M.I.Mech.E.,
A.M.I.Mar.E.

The following article is an abridged version of the paper presented by the Authors on January 27th, 1970, at the Institute of Marine Engineers in London.

INTRODUCTION

It is the policy for all future major surface warships in the Royal Navy to use gas turbine propulsion. This policy has been decided upon in order to achieve greater availability, a better weapon payload, simplicity in operation and a reduction in manpower afloat.

The gas turbines are marinized versions of well proved aero engines. These engines are not reversible.

The transmission, gearing, shafting and ancillaries, has to convert the engine characteristics to those of the propeller in the best possible manner, provide the reversing capability, fit the ship layout, meet the requirement of the ship command and be reliable and maintainable.

This paper, from the section within the Ship Department of the Ministry of Defence responsible for propulsion transmission systems, describes how the various components of the system are chosen, and considers the problems associated with the transmissions of warships driven by gas turbines.

TRANSMISSION REQUIREMENTS

In order to carry out his task, the designer must bear a number of considerations in mind. Some of these are listed below, not in any order of importance since this may vary depending on the particular design.

Operator Requirements—speeds (maximum, slow, cruising), acceleration, stopping distance.

Military requirements—noise, habitability, shock.

Characteristics—of prime movers, hull, propulsors.

Costs—development, initial and through costing.

Time-scales—for development, testing and production.

Reliability—effect of breakdowns, time between refit.

Maintenance—requirements and accessibility.

Manning—the manpower to operate and maintain.

Training—specialist operator and refitting knowledge.

Logistics—requirements for spares, etc.

Standardization—similarity throughout the Fleet.

In order to establish the system parameters a simulation is carried out of the machinery driving the hull in all the operating modes and various failure states. From this study the design requirements for each component in the system may be stated and used as a basis of equipment selection.

SYSTEM SELECTION

With unidirectional gas turbines the major decision to be made is on the best way of achieving astern power, with a controllable-pitch propeller or a reversing gearbox. These are compared under a number of headings below. Alternatives, such as electrical systems, are not discussed since, at this time, they have not been developed sufficiently for use in warships.

Operational

Controllable-pitch propellers in naval ships change from ahead to astern pitch by rotating the blades through zero pitch. This means that there can be no overlapping of the blades and hence blade pressures are higher than for the equivalent fixed-pitch propeller. The hub diameter is larger than that of a f-p propeller and the blade roots need to have thicker sections in order to take the bending moment while blending into a swivelling circular palm. The net result of these limitations is that a c-p propeller has an inferior form compared with a f-p propeller, leading to lower efficiency with the possibility of cavitation.

To manoeuvre with a c-p propeller, engine power and pitch can be matched to meet the operator requirements by suitable controls. Controllable-pitch propellers have a design pitch and operation off this pitch reduces efficiency and further promotes cavitation. It is, therefore, desirable to operate the propeller as a f-p propeller over the whole ship speed range for normal operation and use the variable pitch facility only for reversing. This type of operation is made possible with a free power turbine which at low ship speeds can operate below its unloaded idling speed to match the full pitch characteristics of the propeller. For rapid manoeuvring, however, better response can be achieved by varying propeller pitch with changing engine power. FIG. 1 shows an example of each of these operating modes.

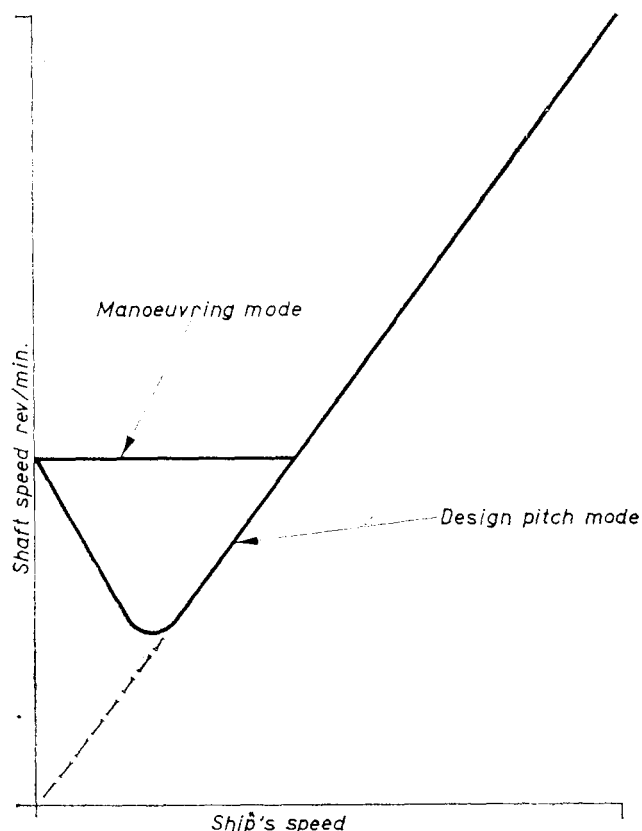

FIG. 1—TYPICAL SPEED/RPM CHARACTERISTIC FOR A C-P PROPELLER INSTALLATION SHOWING ALTERNATIVE OPERATING MODES

The Royal Navy has 25 reversing gearboxes at sea in major warships. These have been satisfactory in service, although they are complicated to operate and require user skill and technique; under very difficult conditions maloperation could occur.

Reversing is achieved by a separate manoeuvring train incorporating fluid couplings. In order to limit the size of the couplings and the oil quantity, the power transmitted through the coupling must be limited.

A new design is being developed which incorporates in-line fluid couplings for manoeuvring and reversing and lock-up clutches in parallel which can be arranged to short out the couplings. The fluid couplings will only be used at lower powers and less heat generated by coupling slip has to be

*Reversing gearbox**Unidirectional gearbox*

FIG. 2—ILLUSTRATION OF SIZE DIFFERENCE FOR A DESTROYER COGOG DESIGN

dissipated. At higher powers the couplings are emptied and the drive is taken through the clutch.

In this design, the fluid coupling oil could have its own circuit and coolers so that sharp oil temperature transients will not affect gear lubrication. Furthermore, there would be no unloaded gears during any operation of the gearbox. Simplification of the design, attention to detail at the design stage and comprehensive interlocks will prevent damage by maloperation.

Manoeuvring

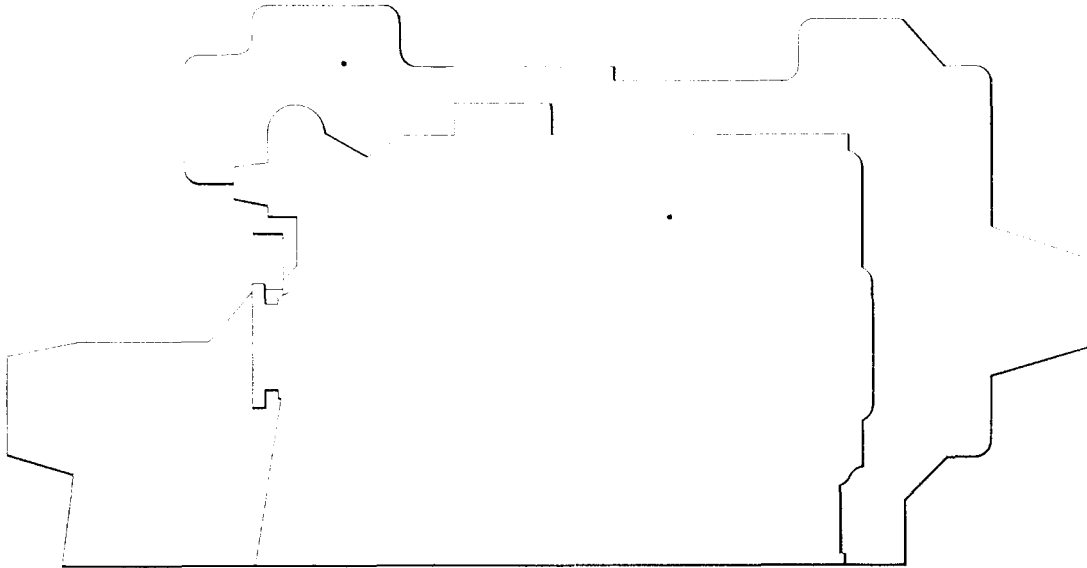
Although computer simulations have been carried out, without two ships, identical except for their reversing mechanisms, it is difficult to compare c-p propellers and reversing gearbox installations on manoeuvrability and stopping distances. Ships with either system are, however, satisfactory.

The capability for stopping a c-p propeller ship depends upon matching of the engine torque build up with the ability of the propeller to transmit the thrust into the water. Much depends on the response of the blades and hydraulic system and the loads that can be accepted in the hub. A problem peculiar to c-p propellers is that when the blades go to zero pitch they form a disc which can effectively blanket a in-line rudder.

With reversing gearboxes, the stopping distance is a function of the torque that can be transmitted through the fluid couplings when the two halves of the coupling are rotating in opposite directions. It is possible to use the natural braking of the ship so that correct choice of the phasing of the application of the couplings has a marked effect on the coupling size.

Size

As a straight criterion, size is not always valid, for the aim is to make the best use of the space available.

Controllable-pitch propeller systems incorporate smaller gearboxes but separate hydraulic pumps, coolers and tanks.

Reversing gearboxes require extra oil for couplings and this too may involve extra pumps, coolers and tanks. These gearboxes are generally larger than

those for c-p propellers as shown in FIG. 2. Occasionally in a multi-engine installation this difference in size is very small, since the positioning of the engines often dictates the gearbox size.

Maintenance

For c-p propeller installations the gearbox is simple and unidirectional. It is never stalled under heavy torque and there is no risk of slow speed scuffing. The hydraulic system has to be sealed where the oil passes into the shaft. If the hub requires maintenance the ship has to be docked.

The reversing gearbox contains more rotating parts and extra complexity from high speed clutches and couplings.

It is not possible to suggest which is the more inherently reliable, but it is to be expected that either, properly designed and produced, will perform satisfactorily.

Cost

Through cost studies have been made for both systems, taking into account capital cost, transmission and propulsive efficiency, refit and breakdown costs. These studies show that, for warships, there is little to choose between either system.

Training, Logistics, Standardization

These constrain the designer from making a purely technical choice. If the Fleet is to consist of a mixture of c-p propeller ships and ships with reversing gearboxes, then there is a penalty in extra training for ships staffs, extra spares holdings and lack of standardization.

The Choice

A large number of points have to be taken into account before committing a class of ship to one or other design of transmission system. Each case must be judged on its merit and by systematically examining each of the requirements, the logical solution appears.

COMPONENT SELECTION

The selection of components depends upon the requirement for each within the system, experience with similar designs in service and the results of research and development. These are in fact all tied very closely. The impetus for research and development stems basically from the projected needs of the future coupled with the experiences with and limitations of machinery in service.

The organization of the Ministry of Defence is such that a specialist section is involved in the problems of the running fleet as well as new design work and research and development. With a large number of ships in service with a variety of prime movers and transmissions, it is possible that any one—guided missile destroyer, *Leander* Class frigate or even coastal minesweeper, may provide information or reveal a problem potentially relevant to new designs. Provided operating conditions in terms of the basic engineering properties, stress, pressure etc., are used, there is no danger in reading across from one ship design to another.

Research and development is carried out for two reasons: to solve problems in the Fleet and to provide the design rules and equipments for the future. For the former much is necessarily rapid and *ad hoc*. For the latter, work is to a more defined plan in order to provide sufficient confidence to design whatever type of transmission is required when it is needed.

The number of options in terms of prime mover combinations and propulsors makes it economically impossible to cover the field in depth. In an attempt to overcome this the research and development is split into two categories. The first of these is common research and development, work which will be of benefit whatever type of machinery is to be used. In the case of specialized items of research and development, which may only have a possible use, spending is carefully restricted until certain decision points have been reached. During this restrictive period much of the thinking and planning of the project is done so that when an affirmative decision is taken the work can be pursued quickly and efficiently. If the decision is not to proceed, then the amount of wasted effort is kept to a minimum. In practice it does not always work so neatly since the decisions are rarely timed to suit the transmission designer.

In many industries where components are small and cheap, a 'suck it and see' approach to development may well be the most economical way of deriving the best product. In marine engineering, testing and development of equipments at full scale is expensive. Economy of testing can be achieved by breaking the work down into three phases: the theoretical analysis, small scale testing (not always essential) and full scale testing. With the analytical tools now available it is possible to gain a good theoretical understanding of most components and systems at a reasonably low cost. The result of this analysis does the initial sorting to reduce the number of physical tests to be conducted, and then defines the parameters for the tests.

Although a comprehensive research, development and trials programme has been drawn up, it is only possible here to highlight some of the more important, and, it is hoped, more interesting projects and the service experience on which they are based.

Propellers

The hydrodynamic design of propellers is conducted by the Admiralty Experiment Works based on tunnel and tank testing. The propellers are cast in a manganese aluminium bronze alloy and finished to a high degree of accuracy.

The achievement of the necessary accuracy is expensive and time consuming as it is at present done by means of hand chipping for the larger propellers or by copy milling for the smaller sizes. A profiling machine of adequate versatility to meet the Navy's needs would be very expensive and could cause a production bottleneck. Instead, a development programme is underway to increase the accuracy of casting so that only light hand polishing will be necessary. Techniques for predicting casting distortions are being developed so that moulds can be biased. The methods of prediction are a fusion of the latest analytical techniques with measured results taken over a large number of years.

Controllable-Pitch Propellers

There are few c-p propeller ships in the Royal Navy due to the preponderance of steam ships with reversible turbines. Controllable-pitch propellers are fitted to some Diesel frigates, survey ships and tugs and H.M.S. *Exmouth*, the first all gas turbine ship. The propeller in H.M.S. *Exmouth* is the first highly loaded one in service and is dealt with separately. In the Diesel ships the c-p propeller has permitted better bmep/speed matching, the pitch being variable from full ahead to astern through zero pitch. Problems have been experienced in the accurate setting of pitch, particularly important being the zero thrust position required for ship stopped condition with the shaft rotating. Accurate calibration with temperature compensation is required to eliminate this error.

The c-p propeller type favoured is that with the hydraulic piston in the hub since this does not require load carrying cranks or rods down the tail shaft.

The hub diameter is generally smaller and there is less mechanical problem than having the piston in the main shaft.

Reduction in hub diameter would lead to increased efficiency and lower blade loading if more of the disc area could be used for blades. The mechanical components of the hub are being critically examined to see where size can be reduced and the feasibility of increasing hydraulic operating pressures without causing sealing problems is being studied.

Shafting

The design rules used by the Royal Navy consider steady state bending and shear stress separately, and take account of reductions of both diameter and fatigue limit by corrosion; these have proved adequate for present designs. More valid design rules are being formulated to take account of all the stresses in the shafting and a study is in hand to produce such a criterion based on full operating stresses. Some work is in progress to establish the actual conditions of loading, taking into account the effect of wake pattern, eccentric thrust, bearing wear, vibration and the manoeuvring transients.

The greater weight of c-p propeller imposes increased bending loads on the main shaft. With warship configuration with long outboard shafts supported by 'A' brackets, the high alternating bending stress can be in an area where the material fatigue limit is reduced by corrosion effects, so that the design must accommodate the combined effects of torsion and bending in an area liable to corrosion.

Experience with oil lubricated stern tube and rubber 'A' bracket bearings has not been satisfactory. Leakage into the oil has caused premature failure of the former and destruction of the latter has occurred if the shaft is not periodically turned when in dock. The present policy is to use sea-water lubricated asbestos reinforced phenolic resin bearings. These give satisfactory service if designed to the correct hydrodynamic criteria, encompassing length/diameter ratio, projected area pressure and rubbing velocity. In cases where the shaft is deflected to a steep angle, the bearing is bored to match.

Face type stern seals are now invariably used. An emergency seal is, however, incorporated to allow maintenance without docking. Research is being conducted to produce better mating materials, such as ceramics, to increase overhaul life of seals in service. A longer term study into the fundamentals of sealing is being conducted in order to meet the sealing requirements of the future. Final testing of seals is carried out in a Ministry of Defence establishment.

Main thrust blocks have been integral with the gearbox in recent designs in order to conserve space. This construction poses problems of access, maintenance and the transfer of thrust through the gearcase structure. Designs are being formulated for separately mounted thrust blocks incorporating facilities for absorbing propeller excited noise and axial vibrations. Such units could be mounted well aft where the ship's lines are finer, so permitting better gearbox mounting such that ship dynamic movements do not affect the meshing of the gear elements.

Inboard shafting has to be supported and watertight integrity at bulkheads must be assured. A simple combination of plummer block and bulkhead gland is being developed but the use of such a component is not always possible, since the position of the shaft components is dictated by the shaft deflected line and the vibration characteristics.

Checks are carried out to determine the acceptability of any shafting design. Using Clapeyron's equation and influence coefficients, the optimum shaft line, to achieve satisfactory bearing loadings, bending moment and bending stress curves are produced. A typical set is shown in FIG. 3. Shaft axial, torsional and transverse natural frequencies are also checked.

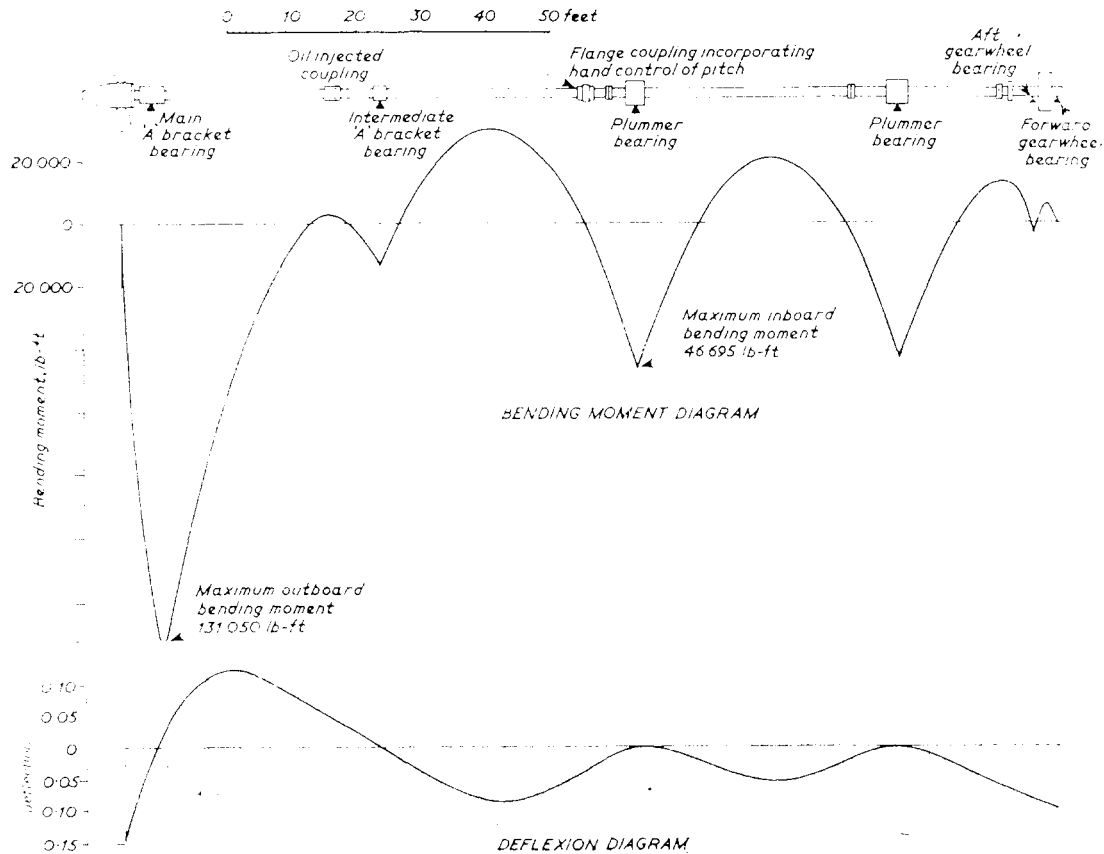

FIG. 3—RECENT SHAFTING DESIGN SHOWING DEFLECTION AND BENDING MOMENT DIAGRAMS

Hydraulics

There has been an increasing use of hydraulics in transmission systems in the last few years. Development work on hydraulic components and systems is carried out on Ministry of Defence sponsored rigs and work is in progress to improve reliability, efficiency and system silencing.

The use of similar components in all the hydraulic systems, developed for the Royal Navy requirements but applicable commercially, simplifies logistics and operator training. They require standards of cleanliness and maintenance which were, until recently, rare in marine engineering. However, the concurrent introduction of other sophisticated equipments and controls has brought about the necessary change of attitude and training.

For c-p propeller hydraulic systems, the aim is to produce a compact power pack using axial piston pumps and flow controlled systems since this has the greatest potential for increased pressure and efficiency. This will permit the engineering of pumps, header tanks, coolers, system valves and piping into a unit small enough to be integral with the main gearing. This will ease the machinery layout, by reducing the amount of piping and drive shafts, simplify local control, fault finding and feedback arrangements, and permit proper repair by replacement by flushed and tested units.

Gearing and Ancillaries

The Ministry of Defence has maintained a full-scale shore transmission test facility of a *County* Class destroyer gearbox driven by two *G6* gas turbines. It has been possible to conduct on this rig a number of independent proving trials to back up the testing done at manufacturers' works and to reproduce the correct environment for developing and uprating in-service components.

Drive shafts and couplings

In the *Leander* Class frigates, the fine tooth flexible couplings between steam turbine and gearing have experienced severe fretting caused by misalignment. The misalignment is a result of differential growths, static deflections of the ship structure under different conditions of payload, and dynamic movement of the hull being transmitted to the gear box and turbine seatings. Palliatives have been strict alignment procedures and also the use of nitrided and sulphinused material combinations and oil retainment collars in the couplings. As a result of satisfactory service of membrane flexible couplings in *Tribal* Class frigates and *County* Class destroyers, a trial is to be carried out in 1970 with this type of coupling in a *Leander*.

In the *Tribal* Class frigate gearing power is transmitted through a long jack shaft from the steam turbine. It has been found that only by accurate alignment and careful balance can the level of vibration, due to the slenderness of the shaft and the disposition of the masses on it, be kept within acceptable limits. This has indicated the need for accurate location and matchmaking of all parts during assembly, for all components and assemblies to be rigorously balanced to a fine tolerance and for accurate alignment of the axes of centres of gravity. It is nevertheless necessary to check that the vibration is below a level indicating a danger of mechanical damage. To do this, accelerometers are attached to bearing caps and an analyser can indicate the plane of correction such that metal can be removed from torque tube flanges to achieve smooth running. A design of coupling flange incorporating balance correction weights is being developed.

In cases where a large engine to gearbox separation is necessary and a conventional torque tube could whirl, a supercritical shaft has been designed and evaluated. In this case the shaft is allowed to run through its first critical at low input speeds, being restrained in damped bearings while it does so.

Clutches

Self-synchronizing clutches are used for the *County* Class destroyer and *Tribal* Class frigate gas manoeuvring drives. These clutches incorporate an automatic disengagement and a lock-in facility to permit various machinery states.

Damage has been caused by inadvertent selection of engagement of the clutch when the input is running faster than the output, resulting in broken pawl and ratchet ring noses. Such damage has occurred with operators inexperienced with this complex gearbox and no interlocks can be incorporated to prevent it. The policy is to simplify the clutch so that the failure regime is not present. Thus, when the automatic disengagement is not required in a unidirectional transmission it will not be fitted. Simplification of the clutch and its controls can also be achieved by removal of the lock, which is only required when there is sufficient reverse torque over a long enough period of time to disengage the clutch against its dashpot.

Fluid Couplings

The fluid couplings for the *County* Class destroyer and *Tribal* Class frigate designs have given satisfactory service and provided precise and simple manoeuvrability. In the Type 82 destroyer the two *G6* gas turbines of the *County* Class are replaced by a single Olympus engine so that twice the power must pass through a single manoeuvring train. The couplings used in previous designs were uprated by a development programme which included decreasing the coupling back pressure to get an increased oil flow through at 100 per cent slip, improving the runner and impeller attachments to permit higher stresses in the limited space, improving production techniques to remove stress raisers, and

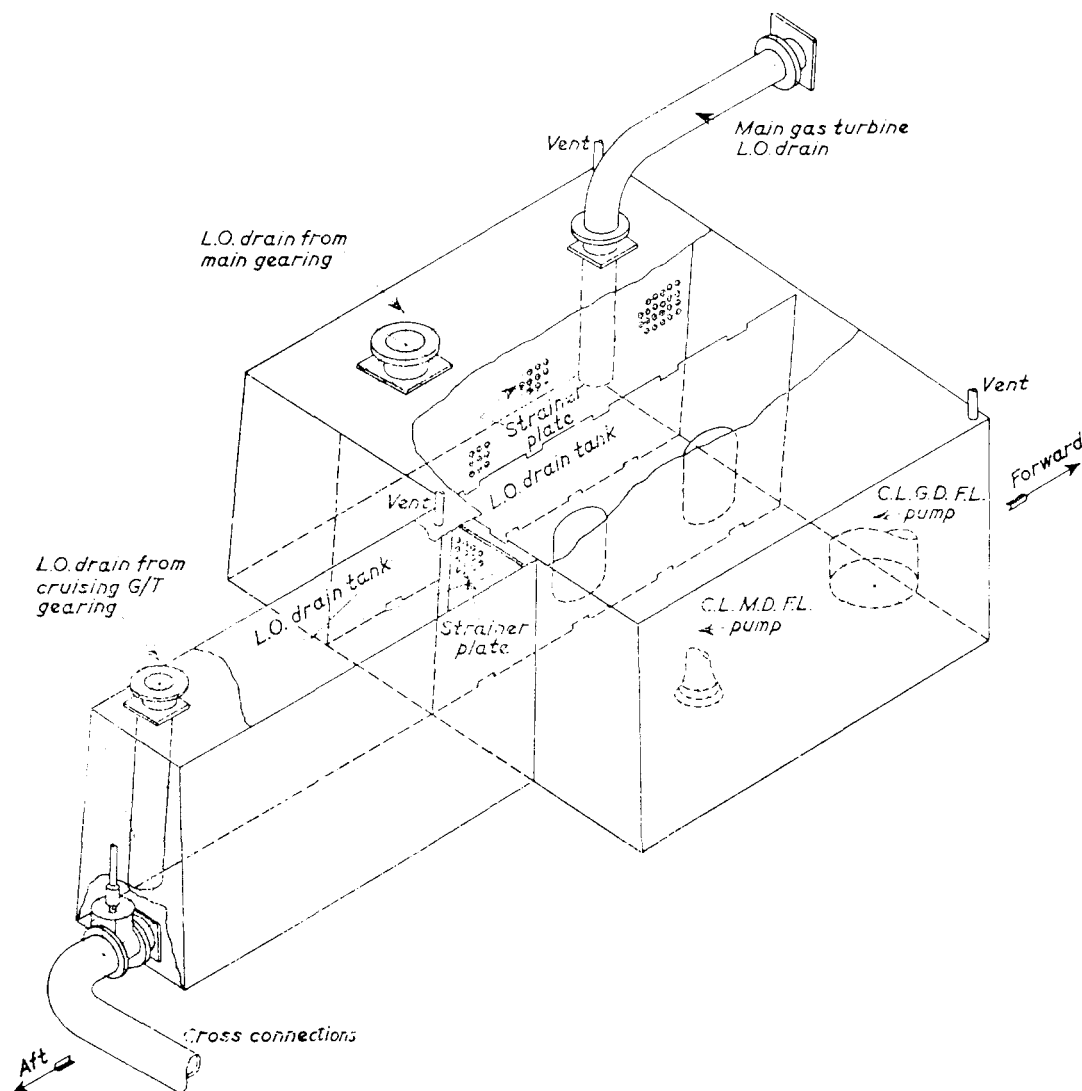

FIG. 4—LUBRICATING OIL TANK DESIGN FOR TYPE 42

checking the natural frequencies and modal shapes of the blades and carrying out modifications accordingly.

Brakes

Brakes are required for assisting clutch engagement on certain reversing transmissions and for arresting the continuously rotating shafting of gas turbine c-p propeller transmissions to prevent wires entangling the screws when berthing, and for other emergencies.

The energy to be dissipated in stopping a shaft system, gearing, propeller and entrained water, and power turbine is such that in order to keep the brake to a suitable size, early single disc designs could only be used with the ship stopped in the water. A design study is in progress to develop an aircraft type multi-disc brake using inorganic pad materials. Having a larger heat sink this will have greater energy dissipation capacity for the same space and should be suitable for use when under way.

Lubricating Oil Systems

The *Whitby* and early *Leander* Class gearboxes were plagued with commissioning problems due to dirt being left in the system during assembly.

Modifications to the gearcase for the later *Leander* Class allowed all internal piping to be straightened and blind ends removed. Proper flushing procedures and thorough inspection has reduced the number of initial and post-refit bearing failures.

Since it is only possible to have small drain tanks in warships, the effect of lubricating oil aeration is noticeable. Steps are now taken in the system design to reduce aeration at source where possible, and to improve drain tank layout to give the best flow conditions to allow the air to be removed by baffles and perforated plates. An example is shown in FIG. 4. This is part of a major study into all aspects of lubricating oil system design which is in progress.

Since the scuffing experienced in the early *Whitby* Class frigates, OEP69 (extreme pressure oil) has been used in all later classes. However, material changes and improved standards of production have made the use of this oil less necessary. As a result of shipboard trials, the Navy Department Fuels and Lubrication Advisory Committee are now assessing alternative oils to OEP69 for use in present and future ships.

Gearing

There have been no recent material problems with gears in the Fleet. Since the introduction of carburized and hardened pinions and through hardened wheels, the *Leander* Class have been free from tooth deterioration. The *County* Class destroyers' and *Tribal* Class frigates' reversing gearboxes, which contain mainly carburized gear elements (with nitrided and induction hardened elements in certain cases) working at K loadings of 500 ahead and 820 when running astern, have also been completely satisfactory. This is adequate proof that these materials are suitable for present designs and the research in progress will permit even higher loadings with the utmost reliability in the future.

It is recognized that, due to the dynamic conditions felt by the gears in a ship at sea, localized loading results so that in effect the gears are subjected to a much higher K value than the nominal design figure. A number of steps have been taken to minimize this:—

- (i) Gearcases for the later *Leander* frigates have been stiffened by the use of a double wall box construction;
- (ii) The correct tip, root and end relief is applied as a result of full scale back-to-back loading trials;
- (iii) Seatings have been improved. The *Leanders* have three area support, one area round the thrust block and smaller areas at the forward end. The Type 82 destroyer has gearboxes supported by a hydraulic constant position mounting system developed by Y-ARD. Investigations are in progress to permit the use of anticlastic bearings, as used in bridges, as three-point supports.

The object of all this is to divorce the gearing from its environment and remove those externally applied loads which upset the meshing, so that the factor of ignorance applied to full-scale load trials results may be reduced.

In addition fundamental research is being carried out by the Navy and Vickers Gearing Research Association (NAVGRA) where the three principal suppliers of naval gearing co-operate to improve naval gear performance and quality. A comprehensive article describing the work of NAVGRA appeared in Vol. 18, No. 2 (June, 1969). (Ref. 11.)

Epicyclic Gearing

The NAVGRA research is applicable to both parallel shafted and epicyclic gearing. Epicyclic gearing shows to advantage particularly in the single engine

per shaft configuration. However, in a multi-engine installation the advantages of its small size cannot always be utilized.

The Brave Class fast patrol boats have two epicyclic stages in series which use the well established Stoeckicht principle. These boats have been in service now for ten years under very severe conditions, and although there have been a number of transmission problems, the epicyclic stages have given no trouble.

The recent innovation of the flexible planet pin has permitted an increase in the number of mesh points and hence a reduction in gearbox size. This has recreated interest in epicyclic gearing within the Royal Navy.

The principle is being tested first on two auxiliary gearboxes in service at sea, a 30 kW (40 hp) electric driven compressor with high starting inertia and a 520 kW (700 hp) total energy gas turbine alternator where the gearbox space is very limited.

A design study is in progress for a frigate main propulsion gearbox which may be back-to-back tested in order to confirm the criteria for this type of design.

The Overall Programme

It has been necessary to deal only briefly with selected components in the transmission in the sections above. It has not been possible in the space allotted to describe the integrated programme necessary for all research and development or to indicate the relative importance of each item, the interdependence or the timescale.

Two recent designs, that of H.M.S. *Exmouth* the all gas turbine conversion and for the Type 42 destroyer, now being built at Barrow-in-Furness, are discussed below to show how the results of the work outlined above are put into practice.

H.M.S. EXMOUTH

In 1965 the Navy Board took the decision to convert H.M.S. *Exmouth* into the first all gas turbine powered major warship in the Royal Navy, where the gas turbines were to be marinized versions of aero engines. The ship was not to be simply a trials ship but was to be able to take her place among the British Fleet in order to give operator experience with the gas turbines, the associated transmission, a large c-p propeller and control system.

This paper is intended to describe how a transmission system is chosen to fit a ship design. However, in many cases some constraint is laid on the designers and H.M.S. *Exmouth* is a case in point. The ship was originally built with steam turbine machinery on a single shaft. In order to meet a short time-scale and keep to a suitable cost the conversion required that the new machinery should not take any greater machinery volume. The gas turbines are unidirectional and as reversing gearboxes are larger than the simpler unidirectional gearbox, a c-p propeller was chosen.

The machinery is a single shaft COGOG (combined gas or gas) arrangement. Two marinized Proteus engines may be used singly or together as cruise and low power engines, and for high power operation an Olympus engine is used.

Manoeuvring may be performed in any of the engines states, the transmission system permits changes from one to another without constraining the ship command.

With a short time-scale it was considered that conversion of a gearbox in service would be more acceptable than the development of a new design. The *Leander* Class gearbox (a variant of the original gearbox fitted to H.M.S. *Exmouth*) was suitable for adaptation.

The input pinion is driven by the Olympus engine through a torque tube and self synchronizing (SSS) clutch. The two Proteus engines drive through integral epicyclic gearboxes via torque tubes and SSS clutches to pinions

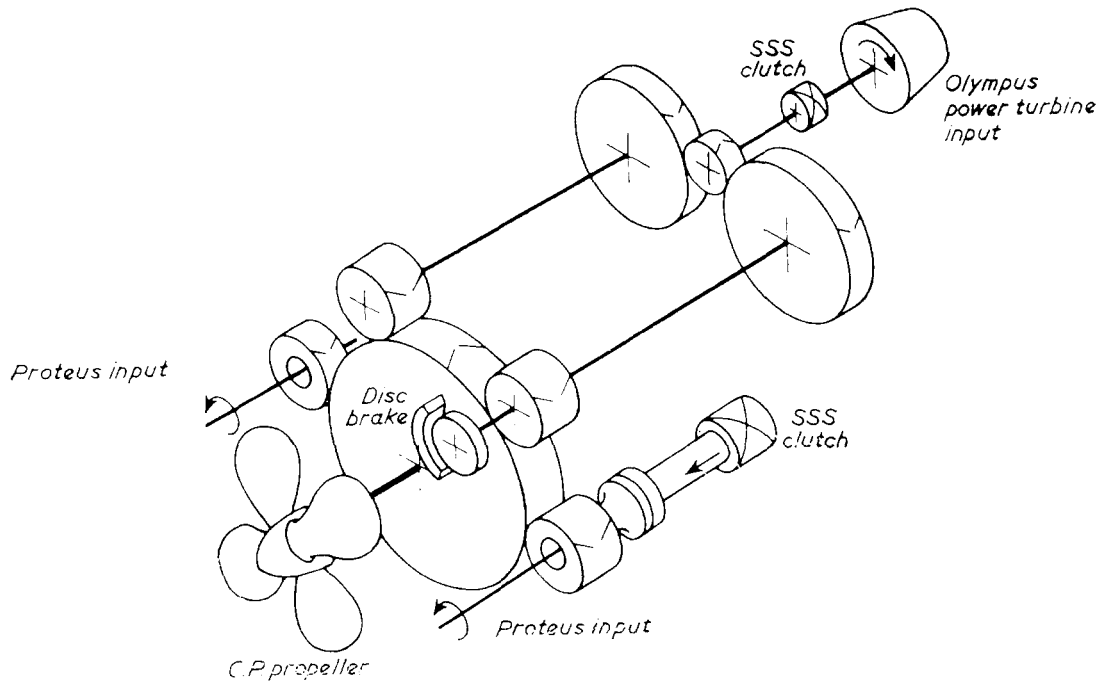

FIG. 5—H.M.S. 'EXMOUTH' PROPULSION GEARBOX—SCHEMATIC LAYOUT OF GEAR TRAIN

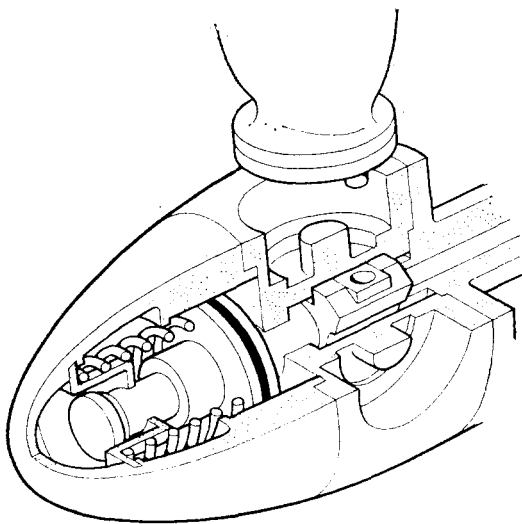

FIG. 6(a)—SINGLE ACTING C-P PROPELLER HUB—H.M.S. 'EXMOUTH'

which mesh with the main wheel, as shown in FIG. 5.

A transmission brake is fitted to a secondary pinion line at the after end of the gearbox. This brake has a single disc of chromium plated copper and two air operated caliper units each with two pairs of organic pads. It stops the transmission and free power turbine rotor in under 15 seconds with engine at idling, propeller at zero thrust pitch and no way on the ship.

Experience has shown that complete action reliance cannot be placed on the supply of electrical power and so lubricating oil pumps driven from the transmission are a requirement. H.M.S. *Exmouth* has a gear driven positive rotary lubricating

oil pump and two electrically driven pumps of the same type. These pumps may be connected either in parallel or in series. When in series the discharge of the motor driven pumps feeds the suction of the shaft driven pump to keep the total flow approximately constant at varying shaft speeds; the motor driven pumps are unloaded at high powers.

The controllable-pitch propeller is the commercial single-acting piston type shown in FIG. 6(a). A double-acting actuator is preferred for naval service but the time available for the conversion of this ship was shorter than that required to develop a new design.

The propeller hydraulic system is powered by two electrically driven screw pumps and one gear driven screw pump. The system is basically a constant pressure type operating at 345kN/m^2 (500 lb f/in^2) with valve control and an

open circuit. The supply and return oil to the hub is fed into the shaft via an oil distribution box at the forward end of the gearbox. This position for the oil entry is chosen since it permits input on the smaller diameter and therefore reduces the sealing problem.

The engine throttle demand is programmed with the propeller pitch. The pitch is increased with engine power up to 1490 kW (2000 bhp) when the propeller reaches design pitch and it remains set for further power increases.

The shafting has to accommodate the larger overhung weight of the c-p propeller and it has to have a sufficient bore to take the hydraulic fluid tubes. The shafting was redesigned to bending and shear stress criteria and the ship converted to take the increased size. The layout, however, has conventional plummer blocks and bulkhead glands, a water lubricated 'A' bracket bearing and a face type stern seal.

After conversion H.M.S. *Exmouth* did a long series of trials from Arctic to Mediterranean conditions. The object was to gain experience with the Olympus engine but it produced some worthwhile feedback from the transmission as well. The most important points are recorded below since they have affected subsequent design work.

Controllable-Pitch Propeller and System

To prevent the possibility of loss of engines due to overspeeding, the control system is arranged so that the throttle demand is slaved to, and always follows, pitch demand on rising power.

With decreasing power, pitch and engine demands were simultaneously reduced. During early trials it was found that the system was not entirely satisfactory. Because of the effects of the hydrodynamic forces on the propeller blades on pitch reduction from maximum, the pitch angle reduced at a faster rate than that demanded by the controls, initially, and consequently the engine speed could rise to a level causing operation of the overspeed trip.

A modification to the control system was effected which cured the trouble. This comprised a low signal selection logical system which ensured that engine power was reduced in advance of pitch.

The c-p propeller hydraulic oil temperature was low, particularly at start up since much lower engine room temperatures are experienced in gas turbine ships than in steam turbine ships. Since the hydraulic pump was initially 'on line' started, this resulted in severe pressure surges which resulted in damaged pump seals. A period of running at low discharge pressure, as a temporary palliative, indicated that the system was working too close to the minimum possible pressure for satisfactory service; it was in fact possible to stall the system and this was partially responsible for the pitch reduction noted above.

As a result of the pressure surges and a sluggish relief valve the hydraulic system pressure peaked at over 690kN/m² (1000 lb f/in²). This caused stretching of some of the bolts in the hub, loosening of the piston nut and some damage to the seals in the distribution box. While this allowed some leakage from the hub and a knock on changing pitch it did not affect the operation of the mechanism.

The accuracy of the feedback mechanism presented problems in H.M.S. *Exmouth*. It appeared that the effect of ambient temperature and oil temperature changes after manoeuvring could alter the pitch by up to 1½ degrees. This was particularly noticeable when berthing and, while temperature compensation would have been possible, the late inclusion of extra complexity would not have been welcomed. The ability to apply the transmission brake enables the captain to prevent his ship creeping and can alleviate the problem. With experience the ships staff can overcome the problem by anticipation and careful adjustment of the controls. However, this cannot be considered the complete

