

ENGINEERING ASSESSMENT OF PWR CORE DESIGN

BY

MR. R. E. JENNINGS, B.SC., M.SC., M.PHIL., R.C.N.C.

AND

MR. K. J. WITTAMORE, B.SC., M.SC., R.C.N.C.
(*Ship Department*)

This article was first published in The Nuclear Engineer, the Journal of the Institution of Nuclear Engineers with whose permission it is reproduced here.

Introduction

There are many aspects of advanced engineering principles that can be, and often are, described by the use of advanced mathematics. Most practical design engineers rarely have the need to use advanced mathematics and are frequently alienated from conceptual design principles by the over-use of this sterile approach. The purpose of this article is to show how interactive computer graphics can be used to give design engineers of any specialization a deep insight into physically complex situations without the need to resort to advanced mathematics.

The Royal Navy has been involved in the development and use of the pressurized water reactor (PWR) over the past twenty-five years. Analysis of reactor core design tends to be performed by scientists who have been thoroughly trained in the techniques of mathematical physics. The authors have chosen this highly-specialized area of engineering design to demonstrate the use of computer graphics in conveying some of the most complex technical ideas. The only skills needed to use the program developed by the authors are:

- (a) the ability to interpret engineering drawings;
- (b) an understanding of a simple computer program guide.

The facilities offered by this type of computer program could be utilized by project engineers who have rapidly to assimilate a wide range of advanced engineering concepts but do not have the time (or, indeed, should they have the need) to absorb the complex details of each subject.

The first PWR was constructed at Shippingport in 1952; although there have been many technical improvements since that time the modern, technically superior reactor has many striking similarities with its early counterpart.

One perennial problem that all reactor designers face is that large quantities of heat have to be removed from relatively small volumes; for the PWR this heat removal rate can be as much as 3 MW per ft³. In order to permit the conduction of this amount of heat from the fuel, the latter is arranged in long thin plates or pins. In the Shippingport reactor about 100 basic modules were constructed in an approximately cylindrical shape within the reactor pressure vessel.

This article demonstrates how simple computer-aided design can be utilized in order to convert basic design concepts into ones that will only need fine quantitative tuning to produce a design ready for engineering production. For the purpose of this work, the structure analysed is the neutron population across one quarter of a module. The quarter module is chosen because it is the smallest symmetrical sub-unit (not including fuel plates) within the reactor. For engineers the desired goal is that the heat be removed from a unit volume of quarter module without causing any uneven local heating effects. Such local heating effects can lead to fuel plate/pin buckling, which could in turn lead to ruptured cladding and coolant starvation above the point of buckling within the channel. Any cladding rupture will inevitably lead to fission products being distributed throughout the primary circuits with possibly dire, and certainly well publicized, consequences for all concerned.

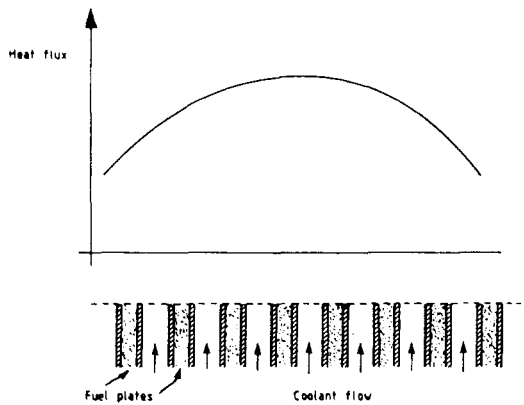

FIG. 1—TYPICAL FUEL PLATE CLUSTER TEMPERATURE PROFILE

This article concentrates on taking the basic Shippingport reactor quarter module and applying some modern physics techniques, such as adding lumped burnable poisons, altering coolant water gaps, and changing fuel concentrations within certain zones in the reactor quarter module. Each of these changes, and their associated effects, are examined qualitatively with the aid of computer graphics in order to give the core designer a fuller appreciation of the sensitivity of certain parameters to changes within the core.

Consider a thermal flux across a unit volume of quarter module as shown in FIG. 1. Let ϕ be measured in terms of MW of heat energy transferring across the face of the fuel plate/pin. Then we would have a simple thermodynamic balance equation of

$$\phi_i = \dot{M}_i C_p \Delta t_i$$

where \dot{M}_i is the mass flow rate up the channel. Because of the basic reactor design and in order to avoid any dynamic instabilities the mass flow rate must be the same in all channels; therefore the equation becomes

$$\phi_i = \dot{M} C_p \Delta t_i$$

If $\phi_i > \bar{\phi}$ then $\Delta t_i > \bar{\Delta t}$, and this means that the design limitations will be set by

the peak flux. Of course the natural consequence of a reactor with a very peaky flux is that its performance in terms of thermal output will be severely limited. In the PWR the temperature also has an important effect on coefficients of reactivity, hence any local cooling (troughs) could have an important consequence on the ability of the reactor to remain stable after load transients. The type of problem discussed in this section is exceedingly difficult to analyse, and thus the purpose of this article is to introduce to engineers involved in all aspects of PWR work the generation and distribution of thermal neutrons, which have a direct bearing on the generation of heat flux. Throughout this article emphasis has been placed on gaining an intuitive understanding of neutron physics by the application of computer graphics.

Shippingport Reactor Construction

As stated earlier, the Shippingport PWR1 was designed and built in the early 1950s and has since become one of the foundation stones of subsequent PWR technology. As such, a great deal of information has already been published about it, and so the description given here will be limited to the facts that are needed to understand the remainder of this article.

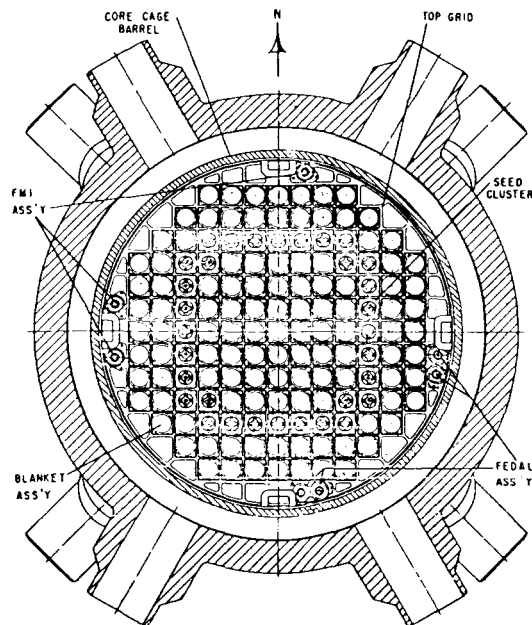

FIG. 2—PRESSURE VESSEL CROSS-SECTION ABOVE CORE

Mechanically, the reactor consists of a pressure vessel and four parallel loops, containing the coolant pumps and heat exchangers. Inside the pressure vessel the fuel modules are located in a core cage assembly at their base and a grid at their top, separated by a core barrel. This in turn is supported at its top end by a ring of helical springs in compression, mounted on a flange in the pressure vessel; vertical thrust from the hydraulic forces on the core and barrel are transmitted to the reactor pressure vessel head through a core hold-down barrel.

Being a breeder reactor, the fuelled area can be split into two regions, known as the 'seed' and the 'blanket' (see FIG. 2). The seed area is a square annulus of 32 modules, containing highly enriched uranium fuel and arranged to give high neutron leakage into the

surrounding blanket areas. These are made up of 113 modules fuelled with sintered, unenriched uranium dioxide (UO_2).

Coolant flow through the individual modules is governed by an orifice at the bottom of each fuel assembly, such that each one receives adequate cooling for the heat generation within that assembly. Coolant enters the pressure vessel through inlet nozzles at the bottom, passes into a plenum chamber at the base of the core cage and then continues vertically upwards through the coolant channels in the fuelled assemblies. At the top of the core the water is constrained to pass up over the core hold-down barrel and then down into the annular space between the core barrel and the pressure vessel wall, before going out through the outlet nozzles.

The basic building block of the blanket modules is the fuel rod, made up of 25 sintered UO_2 pellets stacked inside a zircalloy tube. The ends of the tube are

sealed with a zircalloy plug. 120 of the sealed fuel rods are then made into a fuel bundle, by forming them into a square lattice and welding them to end plates. Seven of the bundles so formed are stacked end to end inside a zircalloy shell to make a blanket module.

Our analysis is performed on the seed modules and so their construction will be described in more detail. The basic component of these modules is the fuel plate, consisting of a fuel alloy sandwiched between two zircalloy cladding plates. The fuel alloy itself is made by melting together highly enriched uranium and zircalloy and then rolling the resultant alloy into a thin plate. This plate material is placed between its two cladding plates and the whole assembly rolled to produce a long, thin fuel plate. After swaging the edges of the fuel plates, 15 of them are stacked together with two end plates and the

swaged edges welded. A quarter module is produced in this manner; four of these quarters are welded together, using zircalloy spacers, to form a complete seed module with a cruciform gap down the centre in which is placed the hafnium control rod. FIG. 3 shows the construction more clearly and includes a detail of the fuel plates, the cooling water gaps between them, and the edge welds used in the build up of the quarter module.

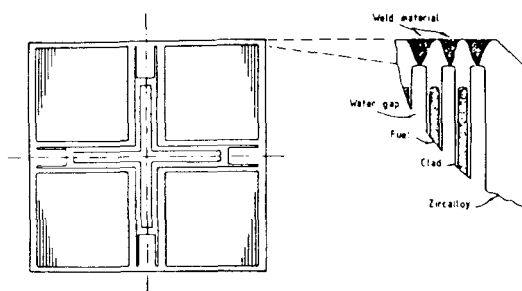

FIG. 3—CONSTRUCTION OF A 'SEED' FUEL MODULE

Elementary Neutron Physics

On the absorption of a neutron, certain heavy nuclei become unstable; in nuclei such as U233, U235, Pu239, and Pu241, the most probable outcome of this instability is that the nuclei will split into two lighter fragments, gamma photons and high-energy neutrons. Fission fragments have a relatively large rest mass in comparison with neutrons and gamma photons. Most of the heat energy obtained from the fission process is gained by arresting the motion of fission fragments. The mean path travelled by these fission fragments is 10^{-4} m, which is more than a decade down on the mean flight path of the neutrons and is also very small compared to all meaningful reactor dimensions. The majority of neutron absorption occurs when the neutrons become thermalized (only true for thermal reactors), hence because of the very short flight path of the fission fragments the thermal neutron flux distribution is a good indication of the sites of heat generation within the fuelled region of the reactor. Hence for this reason most of the work illustrated in this article concentrates on shaping thermal neutron flux profiles.

The most probable energy that a neutron born in the fission process will have is 0.73 MeV, with a mean energy for the spectrum of 1.98 MeV. These neutrons are known as fast neutrons, whilst the neutrons most easily absorbed in order to cause further fissions are known as thermal neutrons and have an energy spectrum which ranges from small fractions of an electronvolt to several electronvolts. In order to thermalize the neutrons they have to be slowed down or moderated. For the PWR the moderator is water, and it is the complex interactions of the neutrons travelling first from the fuelled region through the cladding and then into the moderator which has to be modelled. Neutron paths can be modelled quite accurately using the Boltzmann Transport Equation, and the use of this equation to model neutron behaviour within nuclear reactors has been extensively employed and well documented. A. F. Henry¹ gives an excellent account of the derivation and use of the

neutron transport equation. The computer graphics described in this report were derived by applying a computer program to solve the integral form of the transport equation. The derivation and understanding of this equation has no direct bearing on the subject being described in this article; for readers with a desire to enquire further into the theoretical foundations of the computer graphics, the above quoted work and that of M. J. Roth² are highly relevant.

In order to gain a good understanding of what the computer program can achieve, a simple, although slightly artificial, problem will be considered. The problem is to produce and analyse the neutron flux profiles across a section of three fuel plates of a quarter module of the type described in the preceding section. What are the problems in doing this? The first assumption that has to be made is that we can consider the plates to represent a single dimensional geometry (1-D). This can be done because the breadth and length of the plates are very large compared to their width. Across the width the two end materials are considered to be a smeared fuel/cladding/water homogeneous mixture. In fact a reasonable estimate of the flux profiles has to be derived before the smeared material can be produced; more detail of the smearing process will

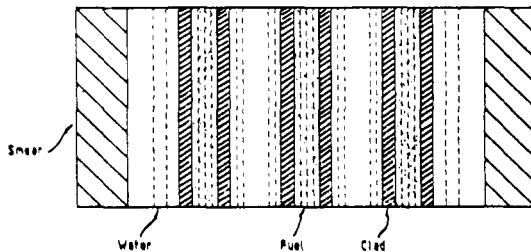

FIG. 4—COMPUTER MODEL OF FUEL PLATES

be given at the end of this section. The input geometry for the fuel plates and associated water gap is shown in FIG. 4. As shown there are 36 independent regions and any number of these regions can be attributed to a single material. By simple manipulation of the input geometry, the water gap, cladding, or fuel regions can be altered in an attempt to optimize the neutron flux profiles.

As stated earlier in this section, the statistical distribution for fission neutrons has a most probable energy of 0.73 MeV, with an average energy of 1.98 MeV. In fact, in most sections of a reactor, neutrons with energies from a fraction of a MeV up to several MeV can be found. In order to analyse this physical situation, the neutron energy spectrum is split into discrete energy bands (e.g. 5 keV to 10 keV, etc.). All other parameters are then said to be energy independent within this band. Of course, the more discrete intervals the energy bandwidth is divided into the more accurate the code will be. However, for the sort of qualitative results required, only four energy intervals were used

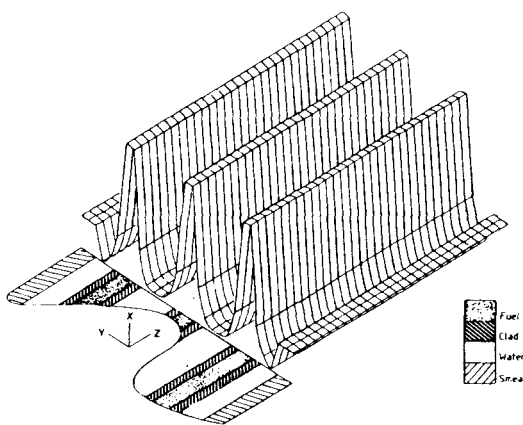

FIG. 5—FAST NEUTRON FLUX PROFILE ACROSS FUEL PLATES

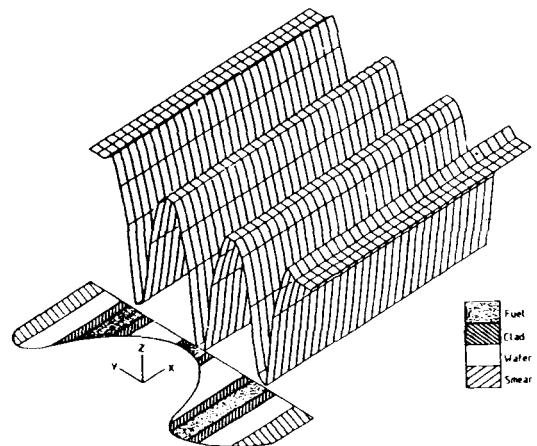

FIG. 6—THERMAL NEUTRON FLUX PROFILE ACROSS FUEL PLATES

in this case. These energy intervals from thermal through to fast are as follows:

0–0.6 eV; 0.6 eV–6 keV; 6keV–0.8 MeV; 0.8 MeV upwards

As far as this work is concerned, the flux profile which will be shown and discussed mainly is the thermal neutron flux profile. However, for a couple of cases the fast flux profile will also be shown, since this will aid the understanding of the slowing down (moderating) process with respect to different material types. The results of performing the transport equation analysis across the three fuel plates are shown in FIGS. 5 and 6. The first of the two figures shows the fast neutron flux profile, which—as would be expected—shows large peaking in the fuelled area. A sharp decline in the fast flux profile indicates just how effectively the surrounding materials are moderating these high energy neutrons. It must be kept in mind that there is a large spectrum of energies across which the neutrons must travel prior to becoming thermalized. FIG. 7 shows the probability distribution of fast neutrons and the translation across the energy which is desired. The figure shows that there is diminution in the total number of neutrons that achieve these thermal neutrons. This can be

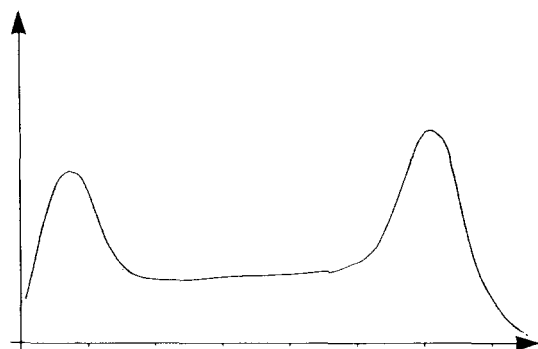

FIG. 7—NEUTRON ENERGY SPECTRUM

mainly attributed to neutron capture (without fission) in the various reactor materials. As can be seen in FIG. 6 the thermal flux distribution is almost the inverse of that for the fast flux, with the peaks occurring in the water gap.

One of the main parameters used in the transport equation is the neutron cross-section which can be visualized as a target area for the neutrons to impact upon. There are many kinds of cross-section, some of which are listed below:

- (a) elastic scattering cross-section;
- (b) inelastic scattering cross-section;
- (c) capture cross-section;
- (d) fission cross-section.

There are others, but the above are the most important to nuclear reactor analysis. Every element has its own set of cross-sections, each of which can vary tremendously with energy. However, it is the macroscopic cross-section that is used most extensively in these physics calculations; this represents the product of cross-section and atom number density and is usually denoted by the Greek symbol Σ . Of course, each reactor is constructed from various materials such as uranium dioxide, zircalloy, weld material, hafnium, boron carbides, etc. The calculation of the main cross-sections for each material is a time consuming and complicated process; fortunately much work has been done on producing data banks of microscopic cross-sections for a full range of reactor materials.

Hence for the fuel plate geometry we start with the following information:

$$\Sigma_{\text{material}, g}$$

where 'material' represents either water, zircalloy, or fuel alloy and g is the energy spectrum over which the parameter is said to be constant. The above four parameters then represent the constant in the following set of linear equations:

$$\Sigma_{Tg} V_j \phi_j = \text{Sum}_i \left[\Sigma S_{gi} \phi_{gi} + \frac{X_{gi} V_i}{\lambda} \text{Sum}_g (\Sigma_{f_{gi}} \phi_{gi} + \Sigma_{r_{g-li}} \phi_{g-li}) \right] V_i P_{ij}$$

where the suffices T, S, r, and f below the Σ s represent total, scatter, removal, and fission cross-section respectively. The parameter X_{gi} represents the fraction of total fission neutrons born into energy group g, and V_i the average number of neutrons produced per fission; these parameters are readily obtained from tables of physics data. P_{ij} is known as the collision probability and represents the probability that a neutron occurring in region i of a reactor will travel to region j. The theoretical background to the derivation and calculation of P_{ij} can be found in the paper by M. J. Roth². In the initial description of the three fuel plate geometry the two boundary regions in the 1-D direction were said to be fuelled region smears. This smearing process is a very important concept. If we terminate the region with either more water, cladding or fuel plates, because of the way collision probabilities are calculated any of the above three options would represent a distortion of the real situation. In order to overcome this difficulty water was initially put in the boundary regions and the flux values calculated. Once this was achieved an equivalent fuel plate/cladding/ water cross-section was calculated using the following formula:

$$\Sigma_{\text{smear}, g} = \frac{\sum_{i=1}^{i=N} \sum_{g} \phi_{i, g} V_i}{\sum_{i=1}^{i=N} \phi_{i, g} V_i}$$

where V_i is the volume of the i-th region, $\phi_{i, g}$ is the g-th energy group flux in region i, and $\sum_{i, g}$ is the compound material cross-section for region i. The smeared or fluxed volume weighted cross-section is then put into the boundary region and the fluxes are recalculated. This process is continued until there is little or no difference between successive flux values in the iterative process. At this stage it can be stated that the flux profile is accurate and that the smeared cross-sections give an excellent representation at a macroscopic level of the behaviour of the fuelled region to neutron bombardment. It is useful to remember that when considering module fluxes the peaks and troughs shown in FIGS. 5 and 6 are just small perturbations on the overall module flux profile. Hence when analysing the quarter module the fuelled region is represented by the smeared cross-section parameter rather than the cross-sections needed for individual fuel plates and water channels. This simplification represents a massive saving on the amount of computing that would otherwise need to be performed in order to analyse the complex structure of PWR quarter modules.

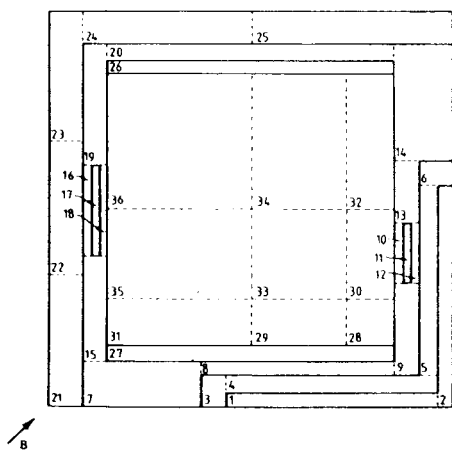

FIG. 8—COMPUTER MODEL OF 'SEED' QUARTER MODULE

Description of Analytical Module and Basic Results

In order to analyse the performance of the quarter module it is first necessary to split it up into 36 rectangular regions, the maximum number that the computer could handle easily, as shown in FIG. 8. The regions are chosen such that each contains either only one material type or a number of materials whose combined behaviour can be described using just one set of physical constants. For example, the fuel plate area in the centre of the quarter module (regions 28 to 36, FIG. 8) is described by one set of flux and volume

weighted physical constants, derived from the earlier analysis of three adjacent fuel plates. Their response to the passage of a neutron is taken to be representative of the behaviour of all fuel plates under those conditions. In the quarter module analysis, the whole of the fuelled area is therefore considered to be a completely homogeneous smear of fuel alloy, cladding plate and water.

Similarly, regions 26 and 27 represent the weld free zones at the fuel plate ends (see FIG. 3), which physically consist of alternate strips of zircalloy and water. For the analysis these are collapsed to one material, a homogeneous mix of the individual constituents, by considering the relative proportions and behaviour of all the elements present. Thus the two weld-free zones become a homogeneous mix of zircalloy and water.

Spacing of the regions is chosen such that they are concentrated in areas in which it is anticipated that the neutron flux gradients will be most severe. For example, in the apex of the control rod scabbard (bottom right-hand corner, FIG. 8), large gradients would be expected because of the high relative concentrations of fuel, water, and absorber. Several regions are therefore clustered around this area.

One of the strengths of the collision probability technique used in this analysis is the ease with which the material attributed to any given region can be changed. Associated with the input data for each of the regions is a single number indicating the material of which that region is made. By changing that single number the physical constants of a different material can be assigned to the region. If it is required to analyse the quarter module with the control rod in, for example, regions 1 and 2 (FIG. 8) are given the material number which represents hafnium. Should the rod-out profile be required, the input data file is accessed and the material numbers for regions 1 and 2 changed from hafnium to water. Thus, it is possible to change the material attributed to any region simply by altering just one number. In the iterative, conceptual design phase of reactor core components, this ability to shuffle materials about quickly and easily is invaluable.

Returning to the analytical representation of the quarter module and comparing FIGS. 3 and 8, it is apparent that the quarter under scrutiny lies in the top left hand corner of the complete module. Several simplifications have had to be made in order to obtain the definition of neutron flux profile required, whilst not exceeding the maximum number of 36 regions. The fuelled area and weld-free zones are homogenized, as mentioned earlier, and the very small water gap at the end of the control rod scabbard has been omitted completely.

A slight sophistication, the purpose of which may not be immediately apparent, has been introduced by including two small regions in the sides of the module (numbers 11 and 17). For the analysis of the quarter module, these are declared as being of zircalloy, in common with their surroundings: at a later stage, these two areas will be available for the introduction of a different material, should it be required to assist in any neutron flux shaping.

FIG. 9 illustrates the results of the analysis of a basic quarter module with the control rod in. The thermal neutron flux profile is shown, being

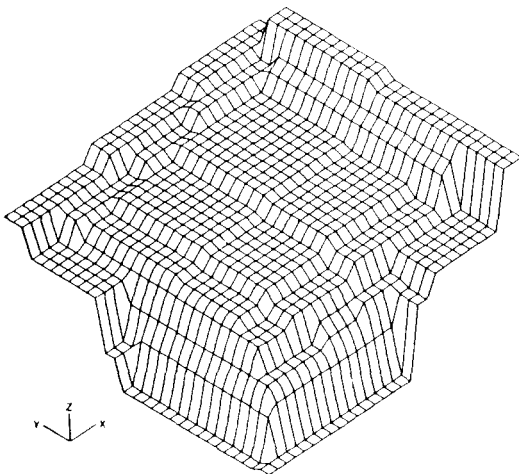

FIG. 9—THE QUARTER MODULE THERMAL NEUTRON FLUX PROFILE—ROD IN

viewed looking directly on to the apex of the quartered control rod, along arrow A, FIG. 8. A careful comparison of FIGS. 8 and 9 reveals that each of the 36 regions can be identified within the flux profile; numbers 1 and 2, the control rod, lie in the foreground, whilst numbers 21 to 25, the inter-modular water gap, form the series of steps along the rear two edges. It is evident that the overall trend of the profile is that of a succession of steps in neutron flux levels, from a peak at the back to a deep trough at the front. Remembering that the technique provides a value for the mean flux in a region and then attributes it in a planar manner to the whole of that region, the series of steps can be visualized as a steady gradation from front to back.

Does the profile obtained fit in with what one would intuitively expect? Consider first the effect of the inter-modular water gap. Its function in the original design would have been to provide a substantial cooling water supply around the outside of the module, but it also has a secondary, and largely unwanted effect—that of thermalizing the fission neutrons. The presence of the large thermal neutron peak so produced has an influence on the neutron population in the surrounding areas, dragging up the neutron flux levels in the nearby fuel. As it is thermal neutrons that cause the majority of fissions, a large number of thermal neutrons will lead to a large number of fissions with the consequent release of significant amounts of energy. Thus, in this rod configuration, the maximum heat production will be in the corner of the module farthest from the control rod.

Precisely the opposite effect can be observed in the fuel nearest the control rod. The rod itself is a strong absorber of thermal neutrons and the flux profile plunges into a deep trough under its influence. The small water gap around the rod helps to pull the levels up a little, as can be seen by the convex shape of the profile in this area, but it is not until the central, fuelled region is reached, that levels are restored. Even so, in the apex of the control rod, the fuel is subjected to a relatively low neutron population and so heat production in this area will also be low. The analysis showed a minimum to maximum variation about the average of just over 25 per cent.—adequate cooling for the near corner of the module under these circumstances would mean considerable over-cooling for the remainder.

Intuitive expectations for the performance of the design are thus matched in considerable detail by the computer analysis. In practice, of course, the hyperfine flux ripple observed in the group of three fuel plates would be superimposed upon the mean levels in the fuelled area: the quarter module calculations have moved the 'scale' of interest from hyperfine to fine flux levels.

By applying the flux and volume weighting technique to the quarter module, a representative homogeneous 'quarter module equivalent' material can be produced. A similar set of calculations performed on the blanket area of the reactor would give a blanket module equivalent material. If these smeared materials are then inserted into their correct relative positions inside the reactor geometry, a trans-reactor neutron flux profile can be calculated. Thus the collision probability solution is capable of providing information at what ever level is required: hyperfine flux profiles at the fuel

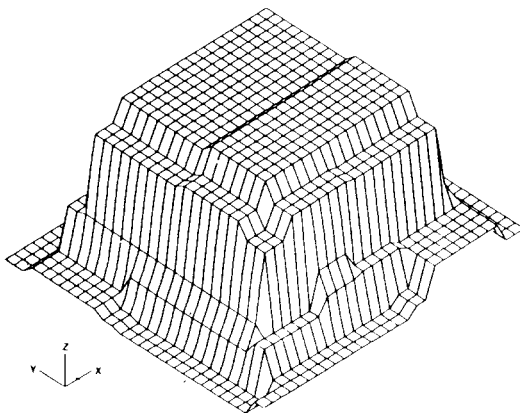

FIG. 10—THE QUARTER MODULE FAST NEUTRON FLUX PROFILE—ROD IN

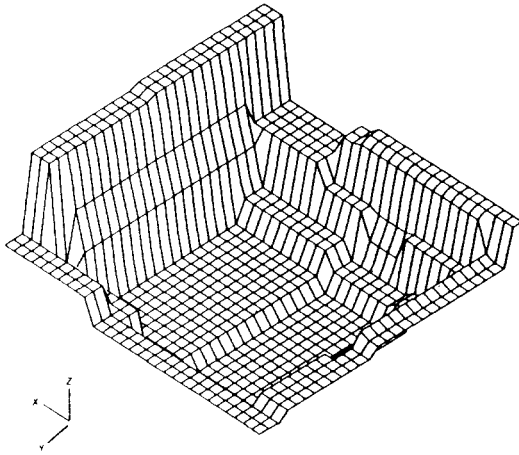

FIG. 11—THE QUARTER MODULE THERMAL NEUTRON FLUX PROFILE—ROD OUT, VIEWED FROM B

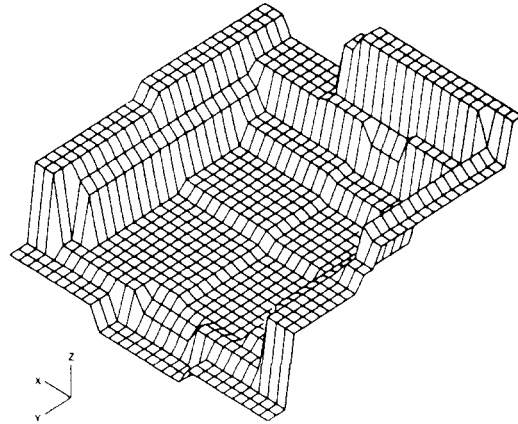

FIG. 12—THE QUARTER MODULE THERMAL NEUTRON FLUX PROFILE WITH WATER GAP REMOVED—ROD OUT

plate scale, superimposed upon fine fluxes at quarter module scale, superimposed upon whole core profiles all leading to the definition of the whole core performance.

For comparison with the more important thermal neutron profile, the fast flux profile for the basic module is presented at FIG. 10. Of note is the fact that at this energy level the situation is dominated by the fuel, where a large plateau is evident. Very few fast neutrons are to be found in either the water gaps or the control rod, and the large gradients indicate that these fission neutrons are slowed down extremely rapidly.

The next stage of the basic module analysis was to look at the thermal neutron population with the control rod withdrawn. The graphical results are presented at FIG. 11, this time viewed looking on to the end of the control rod arm, in the direction of arrow B, FIG. 8. Gone are the steady transitions from water gap peak to control rod trough apparent in FIG. 9. The control rod scabbard is now full of water, which produces its own large peak. This interacts with the intermodular peaks to produce a complex, mountain range of gullies and peaks throughout the fuelled region, posing considerable difficulties for the heat transfer engineer. The hot spot has now shifted from the corner opposite the rod scabbard to that in its apex (region 28), the total variation about the average flux level being 17 per cent. In practice this means that, with the reactor at power, the engineer has to provide approximately 17 per cent. more flow to cool the hot spots than is required to cool the rest of the quarter module. This is highly undesirable and steps must be taken to flatten out the profile across the fuel.

The preceding section illustrated the thermal flux profiles obtained across a seeded quarter module from the original Shippingport reactor. Each diagram showed quite clearly the combination of materials that has the greatest effect on the change in thermal flux profile. The two most marked effects are obtained with water adjacent to fuelled regions and the presence of strong absorbers such as hafnium.

In order to investigate the first effect, the water surrounding the quarter module was removed and a rod-out flux profile was computed; the results are shown in FIG. 12. A quick comparative glance at this flux profile and that shown in FIG. 11 with the presence of the water surrounds shows a large reduction in the water-gap thermal flux profile along the back edge of the quarter module together with a removal of the peak altogether along the orthogonal left edge. Unfortunately, the effect along the left edge is too

dramatic as it pulls down the fission rate in the adjacent fuelled regions below that of the rest. Even with this fault, the overall flux peaking has dropped from a value of 17 per cent. to 7 per cent. It is easy to appreciate that with the use of computer graphics on a VDU, a designer could try to change the amount and position of water gap in order to optimize the flatness of the flux profile across the fuelled-regions/module quarter. Changing the input file in order to reduce or eliminate a certain material requires minor modification to the input file, which can be done in a matter of minutes. Therefore an intuitively and analytically meaningful picture can be produced as a response to a design change within minutes.

FIG. 9 showed the large distorting effect that the introduction of hafnium control rod had along two edges of the quarter module. The hafnium completely removed the thermal neutrons along the arms of the control rod. Boron is another material that absorbs thermal neutrons to the extent that the probability of a neutron travelling through even a thin piece of boron is vanishingly small. Hence the judicious positioning of small regions of boron carbide in the quarter module should have a significant effect on the thermal flux profile. However, it must be stated that one of the main reasons for placing these lumped absorbers throughout the reactor is to hold down the high levels of reactivity that a new core must have in order to attain a long operational life. As the core life advances and more fissile nuclei are destroyed than created then the reactivity of the core reduces; at the same time the neutron flux transmutes many of the boron nuclei to Li and the absorber's total effectiveness is reduced. The core designer has to match the loss of reactivity of the core with the burn up of the absorber. These small regions of boron carbide are normally referred to as burnable poisons.

As stated above, the main reasons for employing burnable poisons is to control excess reactivity; however, core designers can use the poison's effect on the thermal neutrons in order to obtain flux profile control at a macroscopic level. FIG. 13 shows the effect of putting two regions of burnable poison (regions 11 and 17) within the quarter module. Comparing this graphics result with the two earlier ones shows quite clearly that the troughs and peaks have almost been replaced by a flat table top shape. Quantitatively the peak to average ratio has been reduced from 17 per cent. to 7 per cent.

There are two further major techniques that the core designer can utilize to

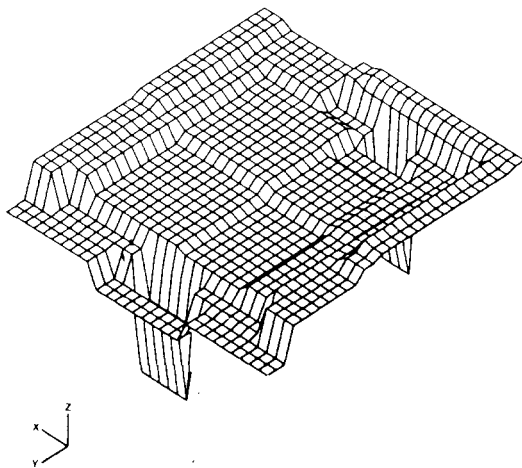

FIG. 13—THE QUARTER MODULE THERMAL NEUTRON FLUX PROFILE WITH WATER GAP REMOVED AND LUMPED POISONS ADDED—ROD OUT

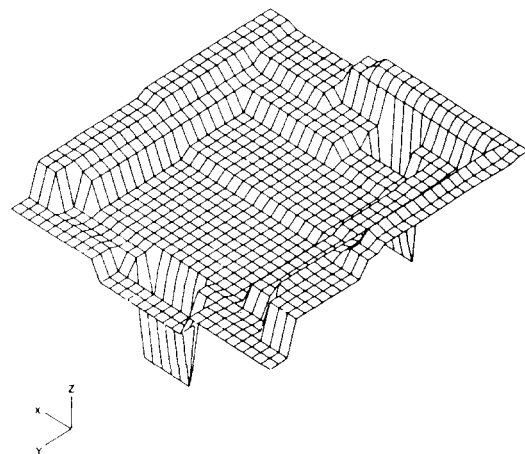

FIG. 14—THE QUARTER MODULE THERMAL NEUTRON FLUX PROFILE WITH WATER GAP REMOVED, LUMPED POISONS ADDED AND THE FUEL ZONED—ROD OUT

improve the thermal neutron flux profile. These are fuel zoning and introduction of chemical shim. The first is a very powerful technique to control thermal flux profile to give very precise control of the rate of burn up of fuel within certain regions of a reactor. An example of fuel zoning technique has been applied to the quarter module, with regions 34 to 36 having a reduced fuel loading. (See FIG. 14.) Once again the flat appearance of the flux profile is maintained; however, in this instance the effect of the burnable poisons significantly masks that of the fuel zoning.

In early phases of core life fine tuning of the overall core reactivity can be achieved by introducing minute quantities of boron into the coolant. This borated water can also be used to control early distortions in the flux profile due to heavy fuel loading. However, for this work, no flux profiles are shown using this technique as the effect tends to be one of an overall reduction in thermal neutron population rather than microscopic flux shaping.

Conclusions

The successful design of any nuclear power plant depends upon the application of scientific and engineering disciplines as diverse as neutron transport theory and fracture mechanics. In order to work together satisfactorily scientists and engineers must be able to explain their design ideas and objectives in an intelligible but succinct manner. This work attempts to show that the concepts of reactor core design can be explained in a simple and intuitive fashion without recourse to abstract mathematical theories. The intelligent use of computer graphics to enhance the designer's ability to think conceptually, without losing sight of engineering reality represents a potent design aid. Despite the theories behind the computer programme used in this paper being beyond the level of understanding of nuclear physics normally attained by engineers and applied physicists, use of the programme as an interactive design tool is available to all who can interpret an engineering drawing and use a computer terminal.

(Further details on certain aspects of reactor core design closely related to the work presented in this article can be found in the bibliography.)

Acknowledgements

The authors would like to thank the Physics and Computing Section at the Royal Naval College Greenwich for their encouragement throughout the duration of this project. Special thanks are due to Mr. D. Gibbs for his technical insight and unfailing enthusiasm.

The views expressed in this article are those of the authors and should not be construed to be those of any Government department or agency.

Bibliography

1. Henry, A. F., *'Nuclear Reactor Analysis'*, MIT Press 1975.
2. Roth, M. J., *'The Estimation of Collision Probabilities in Complicated Geometries'*, AEE Winfrith Report W9775, April 1969.
3. Zeggel, W., *'The Influence of Local Water Enthalpies on the Burn-up Behaviour of PWRs'*, Technische University, Braunschweig, GKSS-77/E/34, 1977.
4. Mastrangelo, V., *'Three-dimensional Model of the Thermohydrodynamic Neutron Interaction in the Core of Light Water Reactors'*, Lyon-1 University, 1977.
5. Berger, H. D. and Oldekop, W., *'Neutron Physical Aspects of an Advanced PWR-type Reactor'*, Annual Meeting on Nuclear Technology, 81. Conference Proceedings, 1981.