

FRANCO TOSI REVERSIBLE CONVERTER- COUPLING WITH DIRECT DRIVE SSS CLUTCH

BY

H. A. CLEMENTS
(*S.S.S. Gears Ltd.*)

AND

E. FORTUNATO
(*Franco Tosi Industrial S.p.A.*)

ABSTRACT

The Franco Tosi reversible converter-coupling provides ahead and astern propulsion within a single hydrodynamic device. Ahead, it operates as a normal hydraulic coupling; the insertion of stator vanes into the circuit causes reversal. Development, testing and typical installations are described, together with the advantages of the system.

Introductory Note (by B. C. Cooper, B.Sc. (Eng.), R.C.N.C., of Sea Systems Controllerate)

The following article, which was written for the American Society of Mechanical Engineers (ASME), describes the design of the Franco Tosi reversible converter-coupling (RCC) and aspects of its development up to 1982. Since then some detail design changes have been made to the rotor assemblies and guide vanes to improve the astern efficiency; however the basic configuration remains exactly as described.

The Franco Tosi coupling is a hydraulic unit that can provide either direction of output rotation from a uni-directional input—making it ideally suited as a reversing unit for use with a main propulsion gearbox. It can therefore be seen as a compact alternative to the conventional fluid couplings and ahead/astern gear trains used in the CVSG and COUNTY Classes.

The bi-directional characteristic is achieved by taking what is essentially a normal fluid coupling and separating input and output rotors axially, thereby making room for retractable vanes to be inserted radially between input and

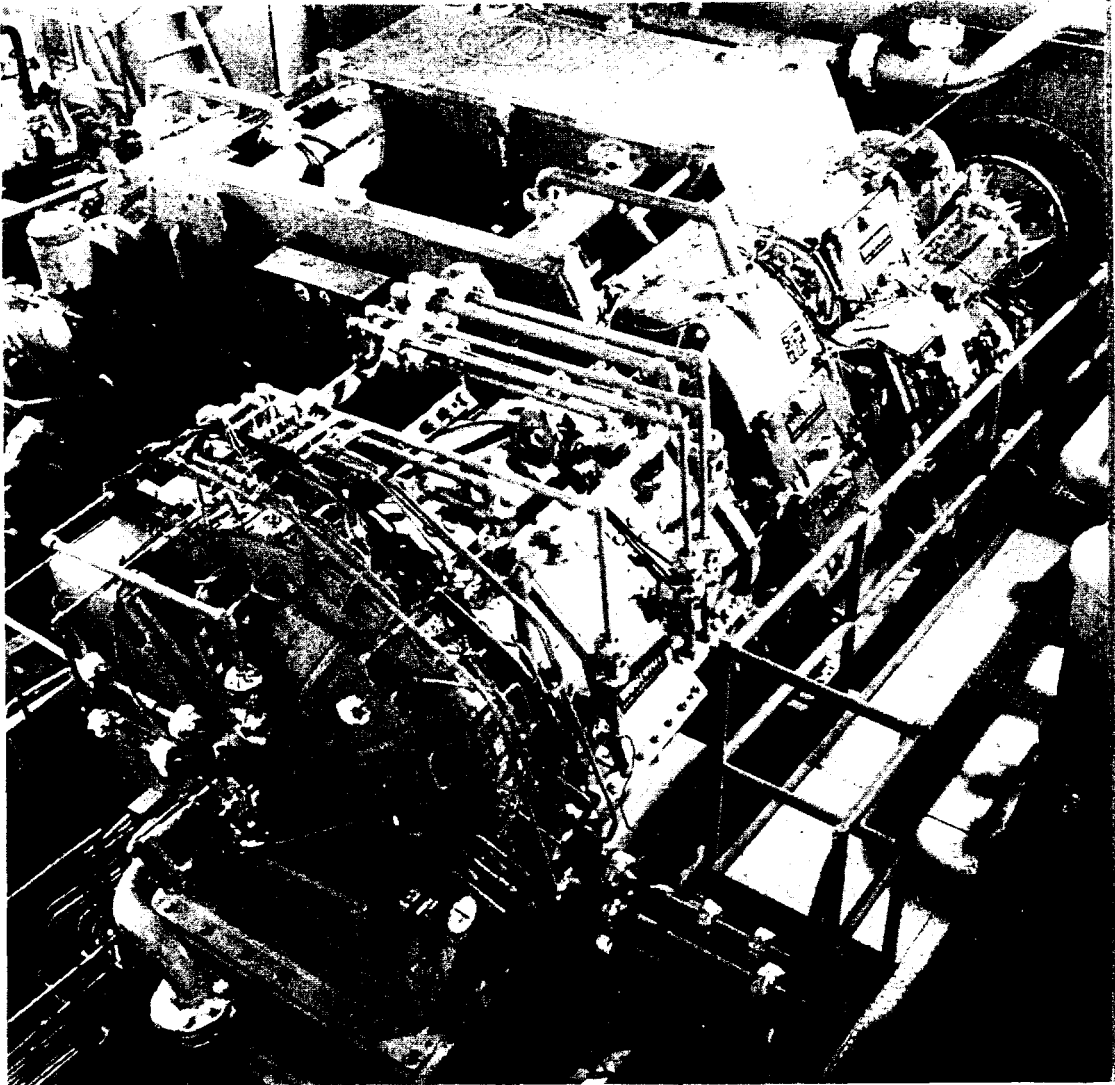

FIG. 1—FRANCO TOSI COUPLING ON FFG 7 GEARBOX IN THE SHORE TEST FACILITY

output halves and resulting in a torque converter which reverses the direction of input rotation. The manner in which the coupling can be integrated into a gearbox is fully described in the article.

To conclude this introduction it is appropriate to summarize experience gained with the coupling and its established applications:

- (a) In service in the Italian Navy carrier, Guiseppe Garibaldi.*
- (b) Comprehensively tested by the U.S. Navy in their FFG 7 Class shore test facility which was specially modified from a standard unidirectional unit to accept a Franco Tosi coupling as a 'bolt on extra' (FIG. 1).*
- (c) Subjected to a more limited R.N. test programme in a purpose-built facility. This will be the subject of a future article in the Journal of Naval Engineering.*
- (d) Under consideration by the U.S.N. for fitting to later ships of the DDG 51 Class. The gearbox for this class was designed to be suitable for either a CPP system or a Franco Tosi coupling, the first batch of ships being equipped with the former.*
- (e) Adopted by the U.S.N. for their new class of fleet auxiliaries (AOE 6), propulsion being by two LM2500 gas turbines on each of two propeller shafts.*

Introduction

There are three usual methods of stopping and reversing a ship:

- Reversible engine.
- Reversing gearbox.
- Controllable Pitch Propeller (CPP).

This article describes a simple reversing transmission, suitable for high-power marine propulsion installations, permitting the use of uni-directional engines and simple efficient fixed pitch propellers.

The reversing transmission is based on the use of a reversible hydraulic converter-coupling, as invented by Franco Tosi Industrial S.p.A., Italy. This is unique as for the first time a single unit in a high power marine transmission system can provide ahead and astern rotation of a fixed pitch propeller. The reversible converter-coupling (RCC) is used for all ship manoeuvring, but for long periods of ahead propulsion it is bypassed and a synchro-self-shifting (SSS) clutch is used for efficient 'no slip' transmission of power.

The reversible converter-coupling will apply reverse thrust to the propeller extremely rapidly, possibly faster than any other system.

History of Reversing Gearboxes for High Power Engines

Many designs of reversing gearbox have been proposed and used during the 20th century¹.

For diesel drives the majority of reverse gears are based on the use of friction clutches, but for high power turbine drives hydrodynamic couplings have usually been adopted because of greater cooling capability and freedom from wearing parts. This experience was started as long ago as 1905, with the invention by Prof. Dr Föttinger of hydrodynamic couplings and converters, which were then used in 1909 in a marine turbine transmission, comprising separate forward and reversing torque converters for ships constructed in Germany^{1,2}.

A development of this concept was used in the Shell gas turbine propelled tanker *Auris*, using a combined hydraulic coupling/friction clutch for ahead propulsion, and a torque converter for astern³.

Possibly the Royal Navy has the most experience with gas turbine reversing gears, as used in 7500 hp and 15 000 hp gas turbine drives for their COSAG vessels^{4,5}; also in each of the 25 000 hp drives of the latest COGAG INVINCIBLE Class ships⁶.

In each of these Royal Navy reversing gearboxes, there are separate ahead and astern hydraulic couplings, which are selectively filled with oil to provide ahead or astern rotation of a fixed pitch propeller.

Such hydraulic couplings, when in use, have continuous slip loss. Therefore, for the long periods of ahead propulsion, the couplings are bypassed by engaging a direct-drive clutch. This is achieved whilst the vessel continues at speed by means of an SSS clutch.

Reversing gearboxes incorporating either friction clutches or hydraulic couplings in separate drives for ahead and astern propulsion, require additional gearing. This involves greater gear losses, and also more space and weight. This additional gearing usually rotates without load when the ship is being propelled ahead, and this could be a serious source of noise, which would be a problem, particularly in naval vessels. To reverse the propeller, power must be transferred between the separate ahead and astern clutches/couplings/converters, and this entails precise timing in order to avoid overheating or engine unloading problems.

The problems associated with the additional astern gearing were overcome in the *Auris* tanker by the use of an astern torque converter. However, the disengaged unit (i.e. the friction clutch, when going astern, and the torque converter when going ahead), can be subjected to overheating.

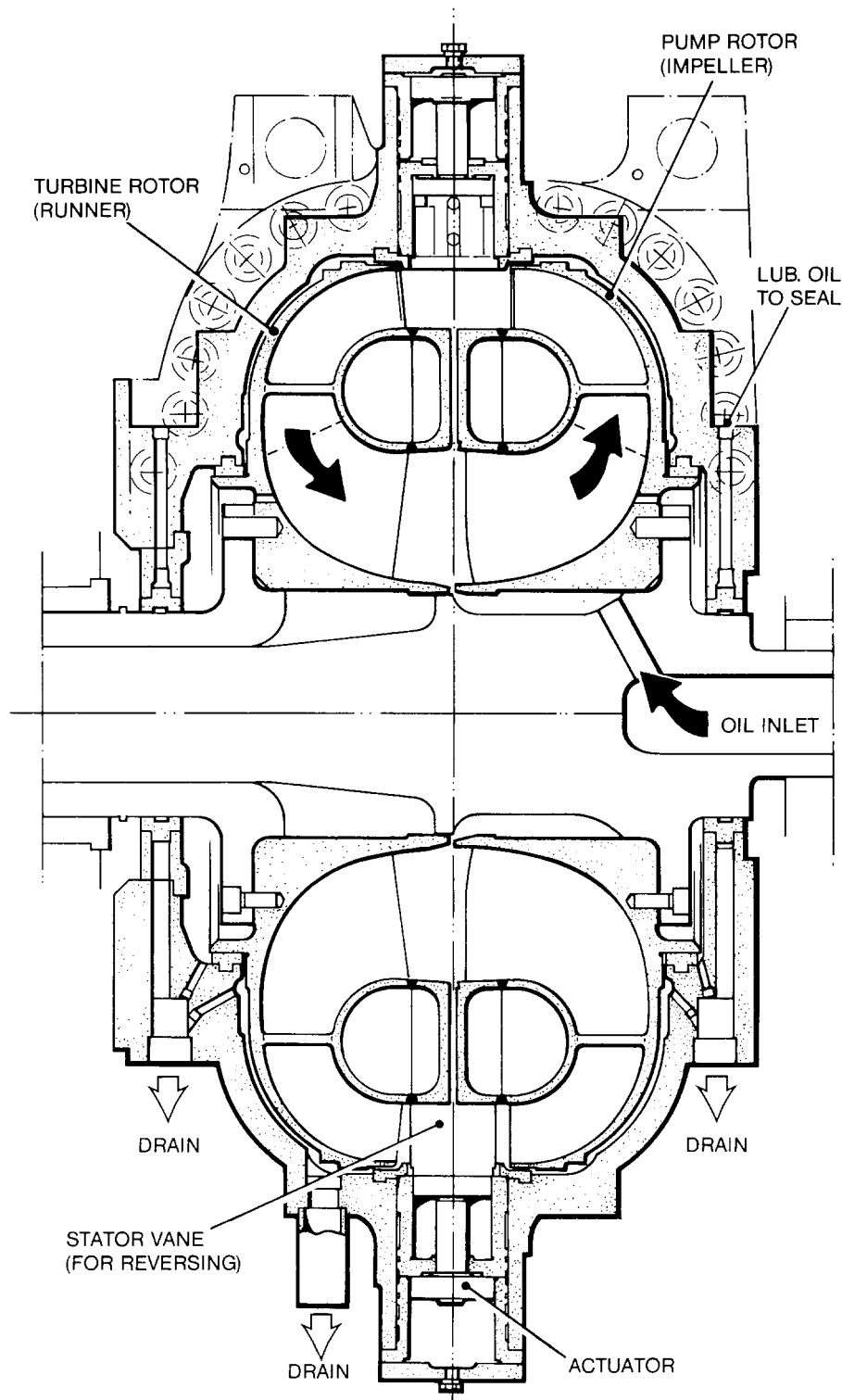

FIG. 2—SECTIONAL ARRANGEMENT OF REVERSIBLE CONVERTER-COUPLING

Operation of the Reversible Converter-Coupling

The RCC provides both ahead and astern propulsion with a single hydrodynamic device built into a high power transmission system, thus making it unnecessary to have separate ahead and astern gear trains, and avoiding the need for precise timing when transferring power between separate ahead and astern devices.

The device is shown in FIG. 2. It consists of a primary impeller, which acts as the pump unit and is rigidly connected to the driving shaft, and a secondary runner, which operates as the turbine unit and is rigidly connected to the driven shaft. Enclosing the pump and the turbine rotors is a stationary oil-retaining casing. This casing supports a series of radial pistons, to actuate stator vanes which can be radially inserted into, and withdrawn from, the space between the pump and turbine rotors at their outer peripheries.

In the ahead operating condition, with the stator vanes withdrawn, the unit acts as normal hydraulic coupling, so when the circuit is filled with oil, the runner rotates in the same direction as the impeller. This is shown diagrammatically in FIG. 3.

In the astern operating condition, the stator vanes are inserted radially into the hydraulic circuit, between the impeller and the runner, in order to reverse the direction of oil flow entering the runner, and therefore to rotate it in the opposite direction to the impeller, as shown diagrammatically in FIG. 4.

Manoeuvring of the vessel is, therefore, carried out quite simply by inserting or withdrawing the stator vanes. The vanes shift their full travel in about two seconds, but braking of the shaft commences almost as the vanes commence to shift.

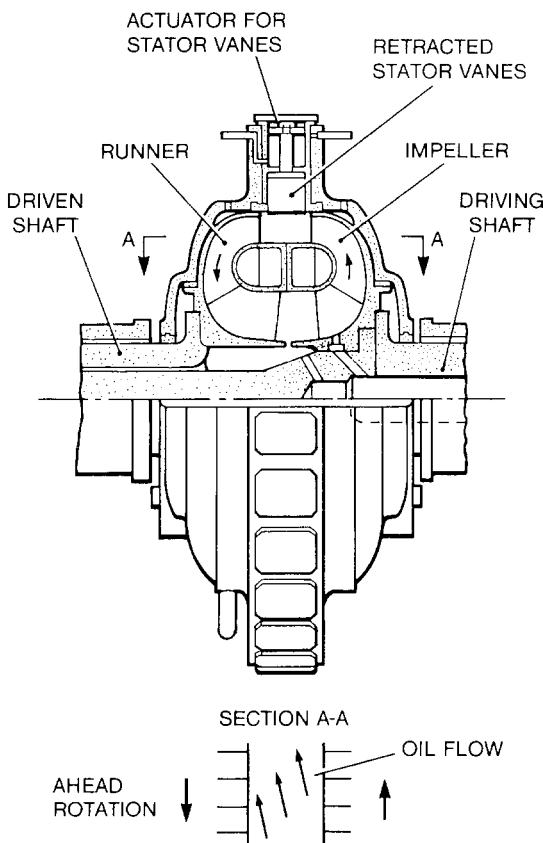

FIG. 3—AHEAD OPERATION

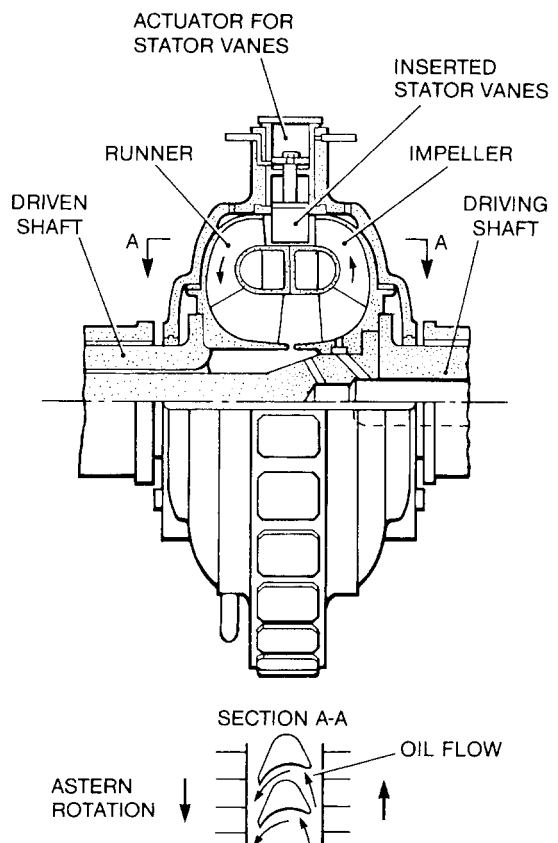

FIG. 4—ASTERN OPERATION

When manoeuvring is completed and the vessel is being propelled in the ahead direction, an SSS clutch mounted in a power path parallel with the reversible converter-coupling, is engaged to eliminate the slip loss therein. Therefore the ship can be propelled efficiently for long periods, driving through the clutch with the RCC empty.

Development

Franco Tosi Industrial S.p.A. first constructed a reversible coupling having a 500 mm circuit diameter. This converter-coupling was subjected to extensive testing between 1976 and 1979 on a test rig¹. After some development work, this coupling had a maximum ahead efficiency of about 78% and an astern efficiency of 52%.

A full size 1000 mm converter-coupling was then constructed for testing, to confirm the theory that a larger converter-coupling with various built-in improvements would have an improved efficiency. This 1000 mm coupling has now been tested and the peak ahead efficiency is about 85% and the peak astern efficiency about 55%.

The ahead steady state characteristics are shown in FIG. 5 (top), and the astern steady state characteristics in FIG. 5 (centre).

A very important feature, confirmed during manoeuvring test, was the torque multiplication characteristic of the converter-coupling when going from ahead to astern, by insertion of the vanes into the circuit. It will be seen from FIG. 5 (bottom) that the output torque is higher than the input torque, and this effect reduces the ship stopping time; also the heating effect on the converter-coupling during ahead to astern manoeuvres. The design, therefore, combines the advantages of a torque converter and a hydraulic coupling, with torque multiplication when going from ahead to astern to improve the ship stopping time, and high efficiency and thus minimum losses when full or empty when the ship is being propelled ahead.

It will be appreciated that the stator vanes are only loaded when inserted into the circuit, that is when torque conversion is required to change the direction and magnitude of the output

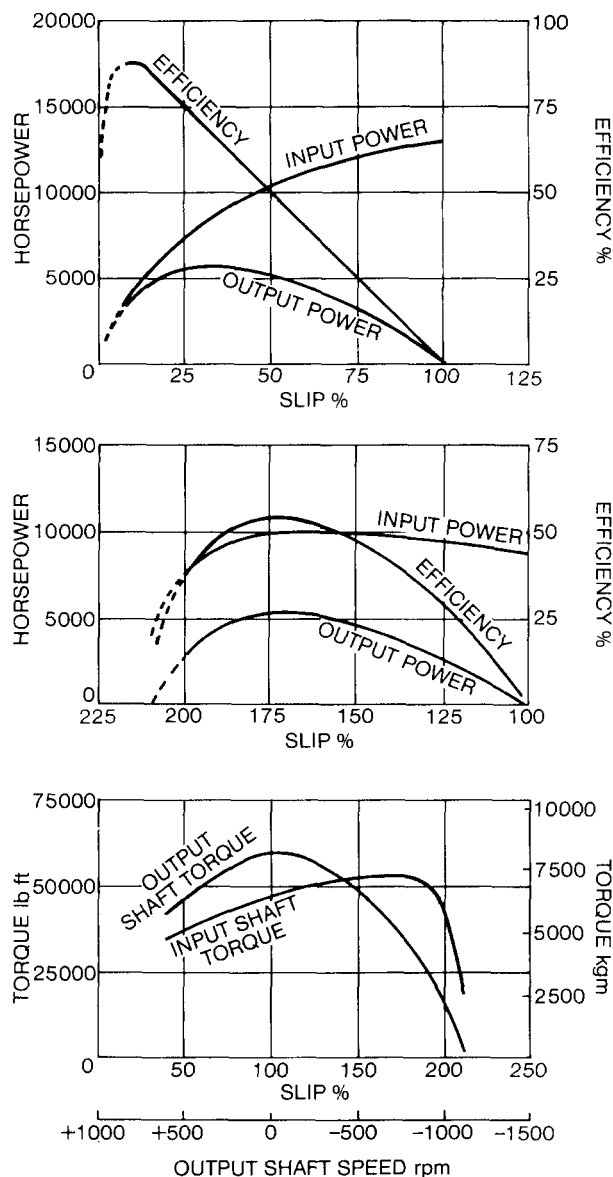

FIG. 5—PERFORMANCE OF 1000 MM CIRCUIT DIAMETER REVERSIBLE CONVERTER-COUPLING RUNNING AT 1000 R.P.M. INPUT SHAFT SPEED (TOP) AHEAD—STEADY STATE (CENTRE) ASTERN—STEADY STATE (BOTTOM) INPUT AND OUTPUT SHAFT TORQUES DURING AN AHEAD-TO-ASTERN MANOEUVRE

torque, compared with the input torque. When going astern, the total torque reaction on the stator vanes is the sum of the input and output torques, and there are therefore fairly high transverse forces acting on each of the stiff stator vanes. These forces react against hardened sliding surfaces, with minimum bending moments. However, it is important to note that during the major part of the time when the converter-coupling is in operation, the ship is propelling ahead; therefore the stator vanes are withdrawn and the sliding surfaces are not subjected to torque reaction forces, which might cause deterioration due to vibrating forces over long periods.

The most critical manoeuvre of a ship is usually a crash stop from high ahead speeds, and to meet such a requirement the stator vanes commence to move from an unloaded condition, and the torque reaction forces are only increasingly applied after the stator vanes are already moving. The stator vane design used in a converter-coupling is, therefore, inherently very reliable.

Most movable guide vane systems in the past have a single mechanical linkage, but for the design of the RCC, each stator vane has its own operating cylinder, so that malfunction of one cylinder does not affect other cylinders, and the ship can still be manoeuvred.

In contrast to other linked inaccessible movable vane systems, the individually operated stator vane assembly used with the converter-coupling only weighs 16 kg and is easily removed in two sub-assemblies, in about 15 minutes, by removing four bolts.

In specifying propeller reversing requirements, it is usual to state the crash astern manoeuvre requirements and, while this is most important, the vast majority of ship manoeuvres between ahead and astern are with low ship speeds, when the requirement is to be able to apply astern or ahead thrust very quickly. The RCC will achieve this objective simply by moving the stator vanes in and out, which takes about two seconds, without complicated transfers between different power paths.

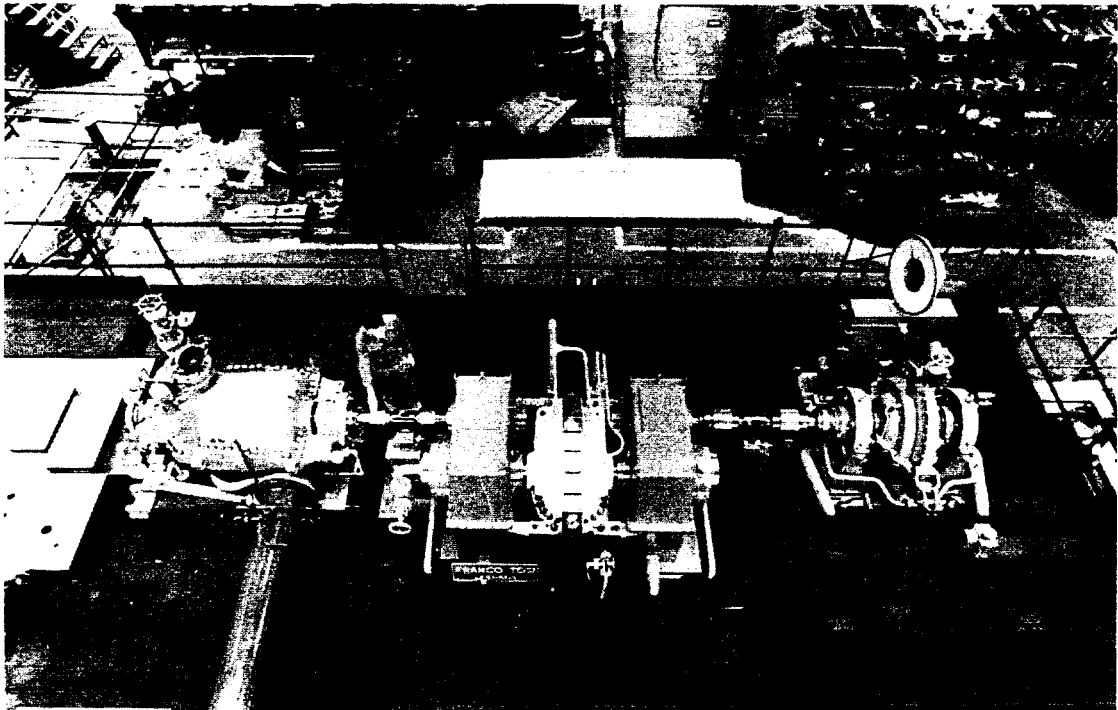

FIG. 6—1000 MM RCC ON TEST: ARRANGEMENT B OF FIG. 8

The full size coupling is shown in test in FIG. 6. In FIG. 7 the top cover has been removed and a stator vane can just be seen between the coupling rotating elements at the horizontal joint.

Testing involved three different test rig arrangements, as shown in FIG. 8. Arrangement A was used during the manoeuvring tests. Arrangement B was used to measure the converter-coupling characteristics under steady state condition, i.e. the power/efficiency performance at various conditions of slip. Arrangement C was used to measure the stalled characteristics both full and empty.

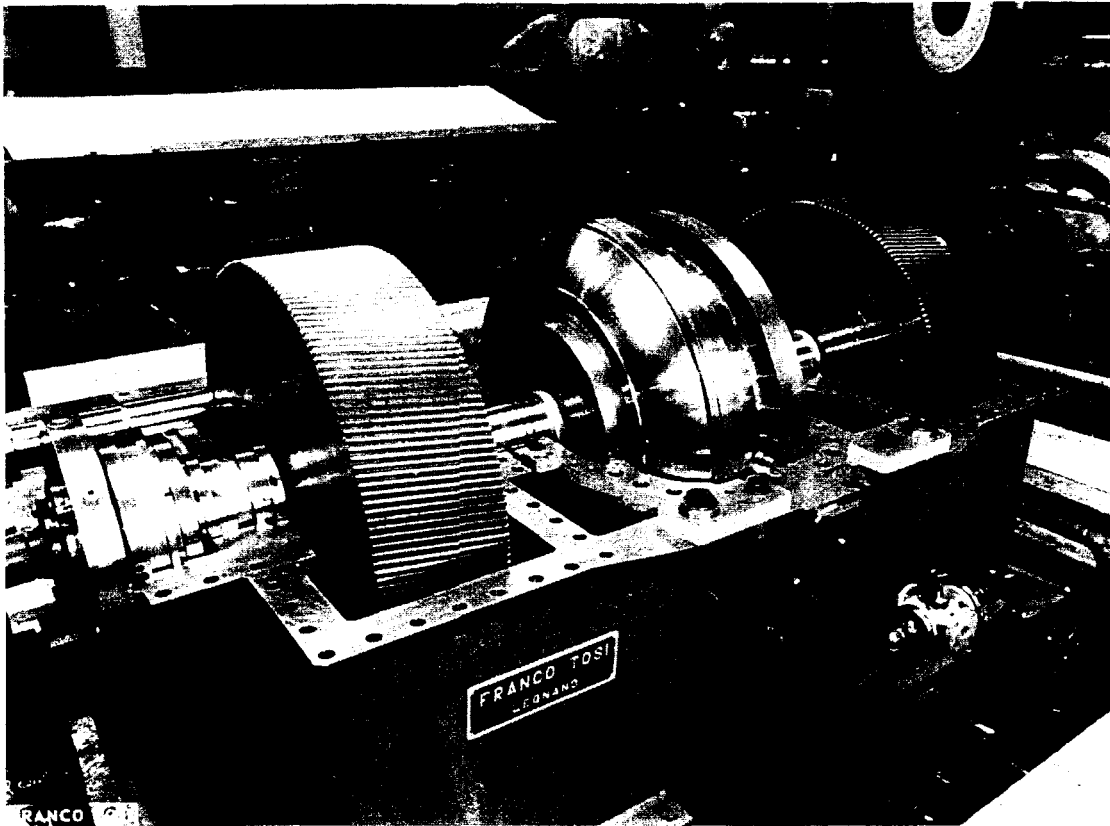

FIG. 7—RCC AND GEARING AFTER TEST, WITH TOP COVERS REMOVED

Other tests carried out were:

- (a) *Thrust on Shafts at Different Conditions of Speed and Slip.* The thrust is in one direction with lower slips ahead or astern and in the opposite direction with higher slips, that is, when the output runner is stalled or rotating at much lower speed than the impeller. The thrust is normally accommodated by the gearbox thrust bearing.
- (b) *Minimum Inlet Oil Pressure to avoid Cavitation.* The improved shape of blades in the 1000 mm rotors, as compared with those in the 500 mm model, has resulted in a lower value of oil feed pressure necessary to avoid cavitation. For the 1000 mm coupling, operating at a speed of 1000 r.p.m., the minimum oil pressure recommended is 4 bar, which gives a very large safety factor to avoid cavitation. Testing has never revealed problems due to cavitation, but it is prudent not to operate for long periods of time in cavitation conditions.
- (c) *Vibration and Noise Levels.* A number of changes were made to the rotor blade shapes of the full-size converter-coupling and tested, and the vibration and noise levels are now extremely low, even when manoeuvring.

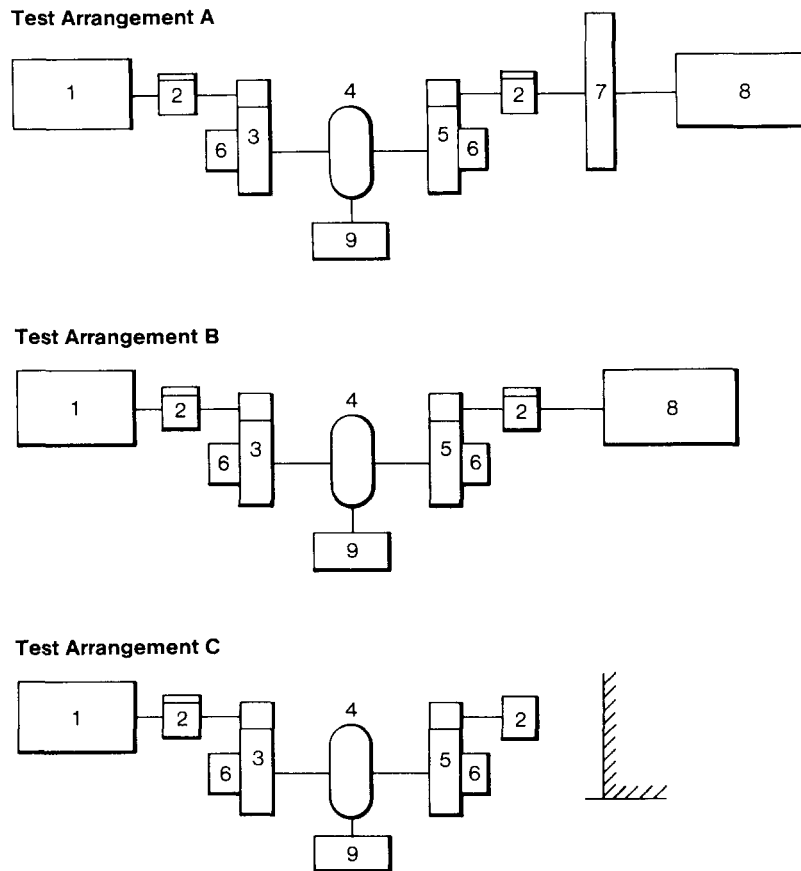

FIG. 8—REVERSIBLE CONVERTER-COUPLING TEST RIG ARRANGEMENTS

- 1: STEAM TURBINE
- 2: TORQUE AND SPEED METER
- 3: REDUCTION GEAR
- 4: REVERSIBLE CONVERTER-COUPLING
- 5: SPEED INCREASER
- 6: THRUST METER
- 7: FLYWHEEL
- 8: HYDRAULIC BRAKE
- 9: FLOW MEASURING TANK

- (d) *Effect of Vane Malfunction.* Tests have been carried out to simulate one or more vanes jammed in or jammed out; also with the jammed vanes in various circumferential relative positions. The astern performance is hardly affected if one or two vanes remain out of the circuit. Modifications have now been made to the rotor blades, so that vibration and manoeuvring performance is still acceptable if one or two stator vanes remain in the circuit.
- (e) *100 000 Vane Movements.* These tests were made with simulated transverse forces. Design changes were made to take account of rapid heat changes and contaminated oil.
- (f) *Windage Losses with the Converter-Coupling Empty and at Various Conditions of Slip.* The effect of air is to transmit power in proportion to the density of air compared with oil. The ratio is about 700:1.
- (g) *Effect of Oil Temperature on the Converter-Coupling Efficiency.* The efficiency of the converter-coupling reduces slightly with increase in oil viscosity, that is, when the oil is colder than the normal operating temperature. The effects on slip and efficiency were checked during comprehensive testing, but it was found that only if the outlet oil temperature goes below about 50°C is a significant change in perform-

ance observed. If the efficiency is lower, the oil heats up more rapidly to compensate.

- (h) *Transient Conditions during Converter-Coupling Filling and Emptying.* Positioning and size of air discharge holes is important, to permit the converter-coupling to fill rapidly. Also the position and size of outlet holes is important, to ensure that it drains fully.

Advantages

Advantages Compared with Reversible Engines

The reversible converter-coupling permits a simpler design of uni-directional engine. For instance, the astern turbine normally used with marine steam turbines can be eliminated to permit a simpler, more efficient uni-directional turbine. Thermal shocks when manoeuvring are reduced, and the turbine and piping can be more robust, so higher pressures and temperatures may be possible. If a re-heat cycle is used, the boiler will be simpler.

Highly turbo-charged, medium-speed diesel engines can present problems when reversed or when required to provide low ship speeds. By using a reversible converter-coupling the diesel engine can continue to rotate in one direction, avoiding multiple starts which may entail precise timing of clutching operations.

Advantages Compared with Conventional Reversing Gearboxes

- (a) The RCC avoids the need for separate reverse gear trains which increase weight, size, losses and noise.
- (b) It remains full of oil during all manoeuvring, so transfer of drive between separate ahead and astern clutches or couplings is avoided, which may involve difficult timing sequences.
- (c) The engine is never unloaded during ahead/astern manoeuvres.
- (d) The RCC has a high cooling capacity in comparison with a friction clutch, and there are no wearing parts mounted on rotating shafts. Also peak temperatures are accurately predictable and controllable, whereas when a friction clutch is used, localised peak temperatures are not predictable, and are difficult to correct.
- (e) The RCC can be used continuously for multiple manoeuvres without temperature limitations, as the associated heat is dissipated in a cooler and metal temperatures do not increase with every successive manoeuvre.

Advantages Compared with Controllable Pitch Propellers

The RCC permits the use of a simple fixed pitch propeller, with the following advantages:

- (a) The well designed fixed pitch propeller is possibly 4% or more efficient than the controllable pitch propeller in ahead, and very much more efficient when in the astern direction.
- (b) With the RCC, the vanes to reverse the ship are mounted on a stationary casing in the engine room, instead of on a rotating shaft in the sea. Therefore, the reversing mechanism is accessible without the need to drydock the ship.
- (c) To achieve slow ship speeds with utmost silence, an important requirement in naval vessels, the RCC can drive the fixed pitch propeller at a controlled slow speed, by partial or group vane insertion. With a controllable pitch propeller slow ship speeds are achieved by fining the pitch, but this unloads the engine, resulting in increased propeller speed and increased cavitation noise.

- (d) As the RCC stator vanes move in or out, the engine remains loaded, whereas in a CPP installation, care must be taken to ensure that the engine power is reduced well before pitch movement takes place to avoid engine overspeeding.
- (e) Oil from the main machinery oil tank is used for converter-coupling control and cooling, whereas the CPP generally needs a separate oil system. The high pressure oil system associated with the CPP requires hydraulic components with close clearances, and trouble can develop due to a contaminated oil system.
- (f) The movement of the vanes in the RCC means a change from the ahead condition to astern in two seconds, compared with a much longer time for CPP. Reverse thrust can therefore be applied more rapidly.

Cooling and Control

With a controllable pitch propeller, the heat generated whilst stopping the ship goes directly into the sea, whereas in the RCC, the heat must go into oil and then pass to water in a cooler, before going into the sea. However, the oil cooling system and increased lubricating oil tank size is not much larger than the CPP control oil system.

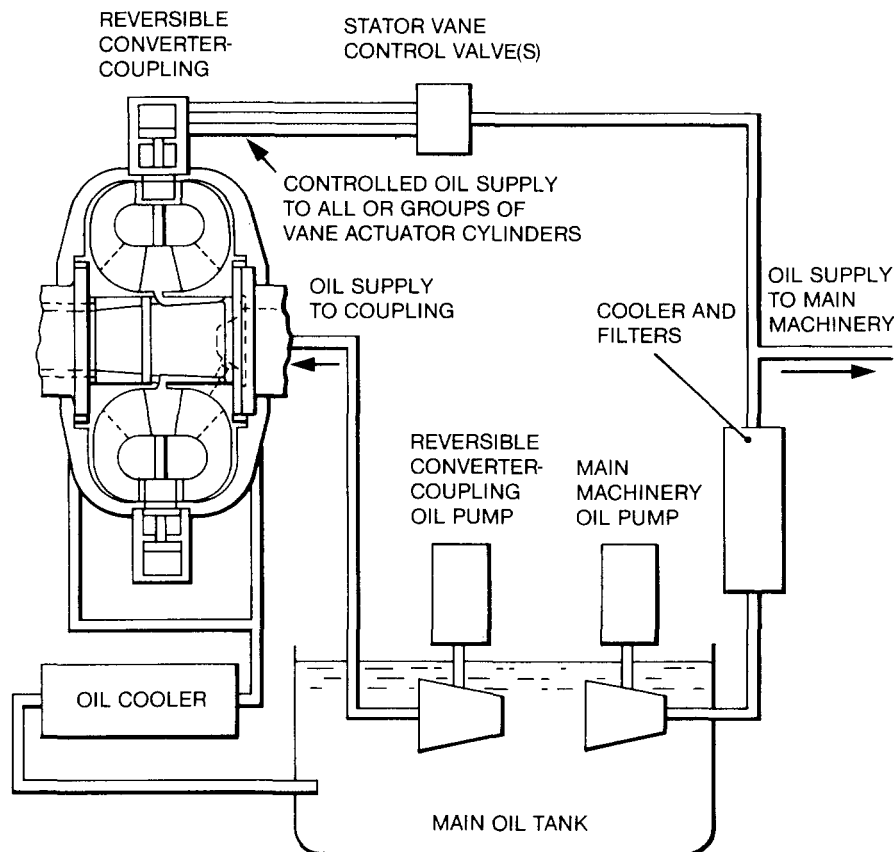

FIG. 9—SIMPLIFIED COOLING AND CONTROL SYSTEM

FIG. 9 shows a simplified cooling and control system, for use when the reversible converter-coupling is in operation.

The rate of oil flow needed through the converter-coupling is usually determined by the heat to be dissipated during the maximum speed astern propulsion condition. The heat generated during a crash astern manoeuvre from full speed ahead is usually accommodated by this oil flow taking into consideration the thermal capacity of the system. In a 25 000 hp turbine

