

# NAVAL ELECTRICAL PROPULSION SYSTEMS

BY

LIEUTENANT-COMMANDER S. K. FIRTH, M.Sc., C.ENG., M.I.E.E., R.N.  
(*H.M.S. Trafalgar, late of Sea Systems Controllerate*)

With all the attention that has been focussed on the Type 23 propulsion system anyone could be forgiven for thinking that electrical propulsion is something new to the Royal Navy. This is not so; FIG. 1 is an advertisement taken from the 1928 edition of the *Naval Electrical Manual* in which GEC proudly proclaim their recently installed system for H.M.S. *Adventure*. The concept and powers involved in that project bear a remarkable likeness to those of the Type 23 frigate. The unfortunate footnote to this story is that the electrical cruise drive facility was removed some years later when it was realized that it was not achieving the fuel economies that were hoped for.

The failure of the plant installed in *Adventure* serves to make an important point about electrical propulsion systems. They will in general, be bigger, heavier and more expensive than any form of purely mechanical system to do the same job. For us to use electrical propulsion in a warship then, there



**G.E.C.**  
**ELECTRICAL PROPULSION**  
**EQUIPMENT**

*of H.M.S. "ADVENTURE"*

*First electrically propelled surface  
 ship for the Royal Navy*

The Plant includes TWO

**1650 K.W. G.E.C. MARINE  
 PROPULSION GENERATORS  
 DIESEL DRIVEN**

and TWO

**2100 H.P. G.E.C. MARINE  
 PROPULSION MOTORS**

Manufactured in England by  
 THE GENERAL ELECTRIC CO., LTD.

The control gear is such that its operation is of the simplest, requiring practically no technical knowledge to operate. The Telegraph orders from the Bridge are actually executed in wonderfully short periods of time, thus ensuring the quickest possible manœuvring of the ship. The most exacting operation, viz., Full Power ahead to Full Power astern, with way on the ship, takes approximately one minute to accomplish.

FIG. 1—GEC ADVERTISEMENT FOR THEIR INSTALLATION IN H.M.S. 'ADVENTURE'  
 From the *Naval Electrical Manual* of 1928, p. xv

must be some heavily counterbalancing factors in its favour. These advantages are usually a selection from the following:

- Flexibility —both of layout and usage of plant.
- Low Noise —important for warships, research vessels and increasingly for auxiliaries.
- High Auxiliary Load —If a ship requires a large generating capacity anyway it may make sense to add a bit more and use electric propulsion.
- Necessity —at present there is no sensible alternative to electric propulsion for conventional submarines.
- Control —electrical propulsion provides better and faster control of propulsion plant.
- 'Soft' Drive —electric propulsion provides a drive which can be stalled without serious damage; this makes it favoured for ice-breaking and tug duty.

Some of these points are illustrated below.

#### *Flexibility*

FIG. 2 is a cut-away view of the M.V. *Seaway Princess*, a Ro-Ro ferry working in New Zealand. The vessel has a single 10 MW gas turbine driving a 50 Hz generator which then drives two 4 MW 200 r.p.m. d.c. motors. The point of interest is that the use of electrical propulsion has here allowed the gas turbine to be sited on top of the superstructure, high above the shaft line. This gets around the potential layout problem of the gas turbine uptakes and downtakes occupying the best position for the vehicle deck entrance. This is of course merchant practice but it illustrates the kind of layout

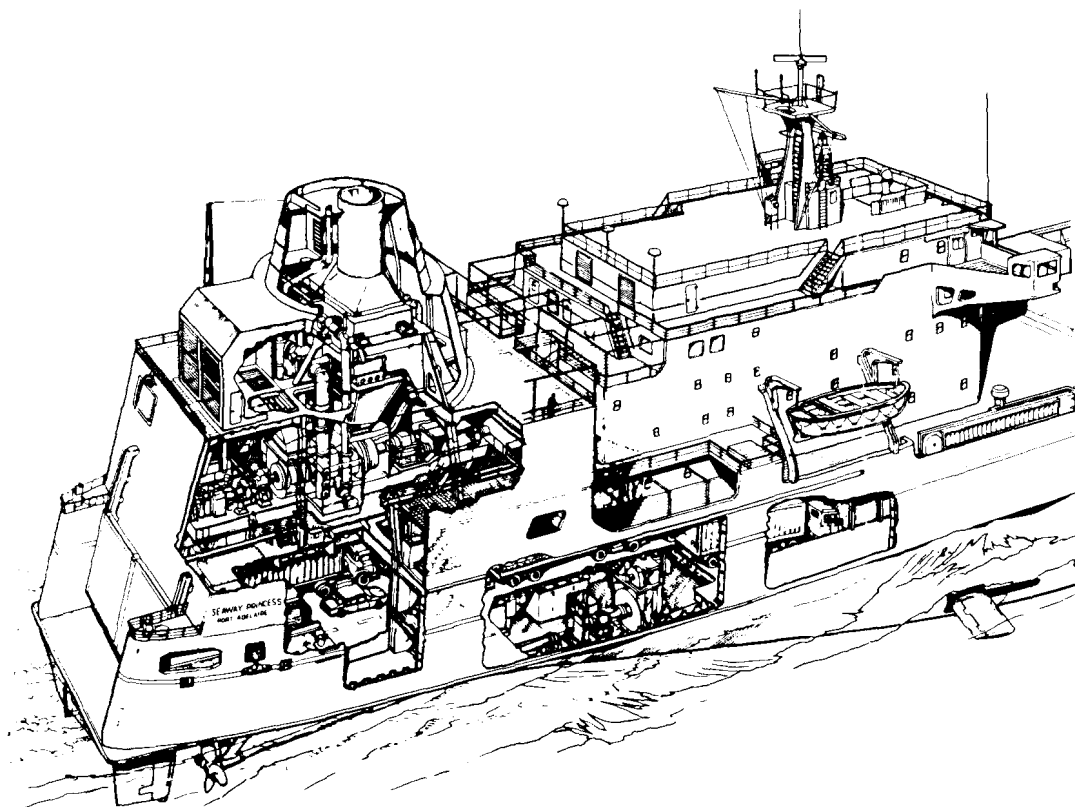

FIG. 2—THE AFTER END OF M.V. 'SEAWAY PRINCESS', SHOWING USE OF ELECTRICAL PROPULSION

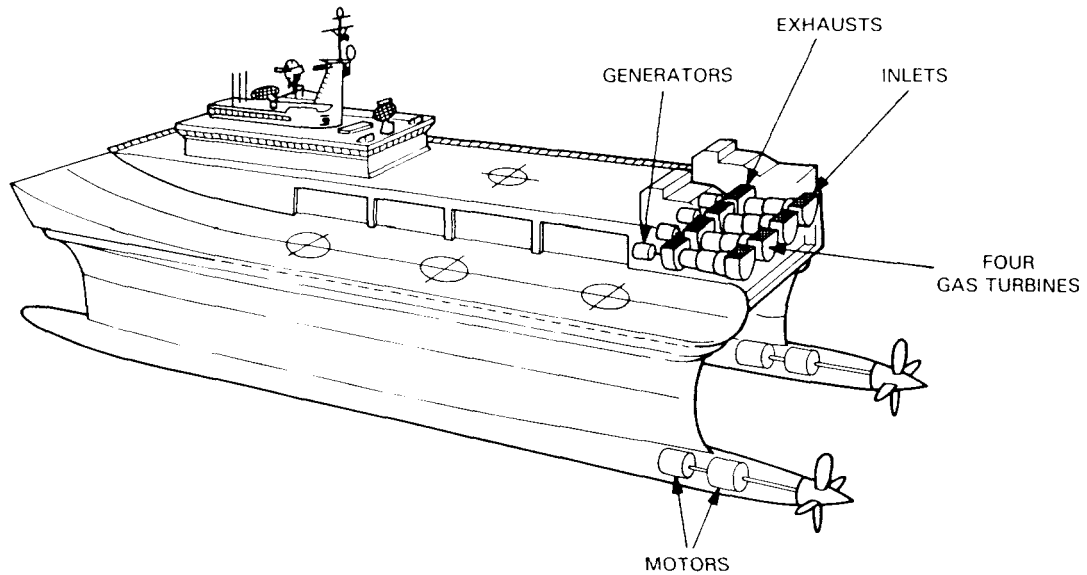

FIG. 3—APPLICATION OF ELECTRICAL PROPULSION TO A SWATH VESSEL

flexibility which might prove useful in future designs of *Fearless* and *Sir Galahad* type ships.

The key point from this is that electrical propulsion allows the separation of the prime mover from the shaft line. This advantage becomes more telling if we look at its application to unconventional hull forms. FIG. 3 is a conceptual sketch of a small aircraft carrier of the Small Waterplane Area Twin Hull (SWATH) type, fitted with an electric drive. Contra-rotating propellers have been proposed for such vessels and the double unit motors in each hull could easily drive these through concentric shafts. The four gas turbine driven generators shown grouped together here could equally well be

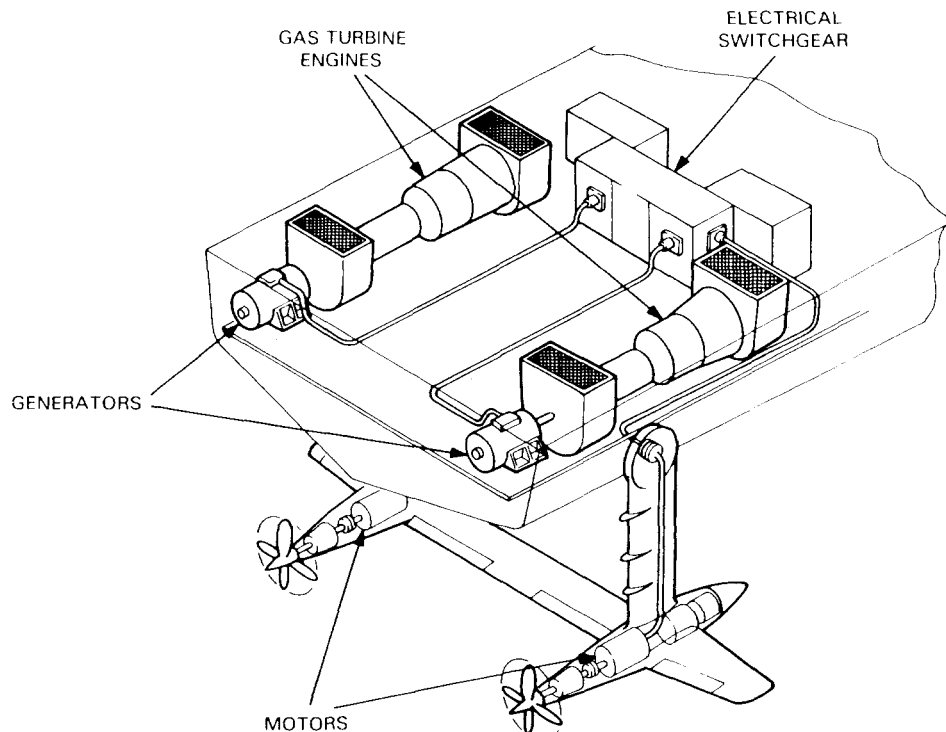

FIG. 4—HYDROFOIL PROPULSION USING ELECTRIC DRIVE

spread out to minimize the effect of action damage. It is difficult to see how a mechanical transmission system could match the simplicity of arrangement shown here, particularly if contra-rotating propellers are required. The sketch of a hydrofoil in FIG. 4 is an illustration of another problem solved more easily with an electric transmission.

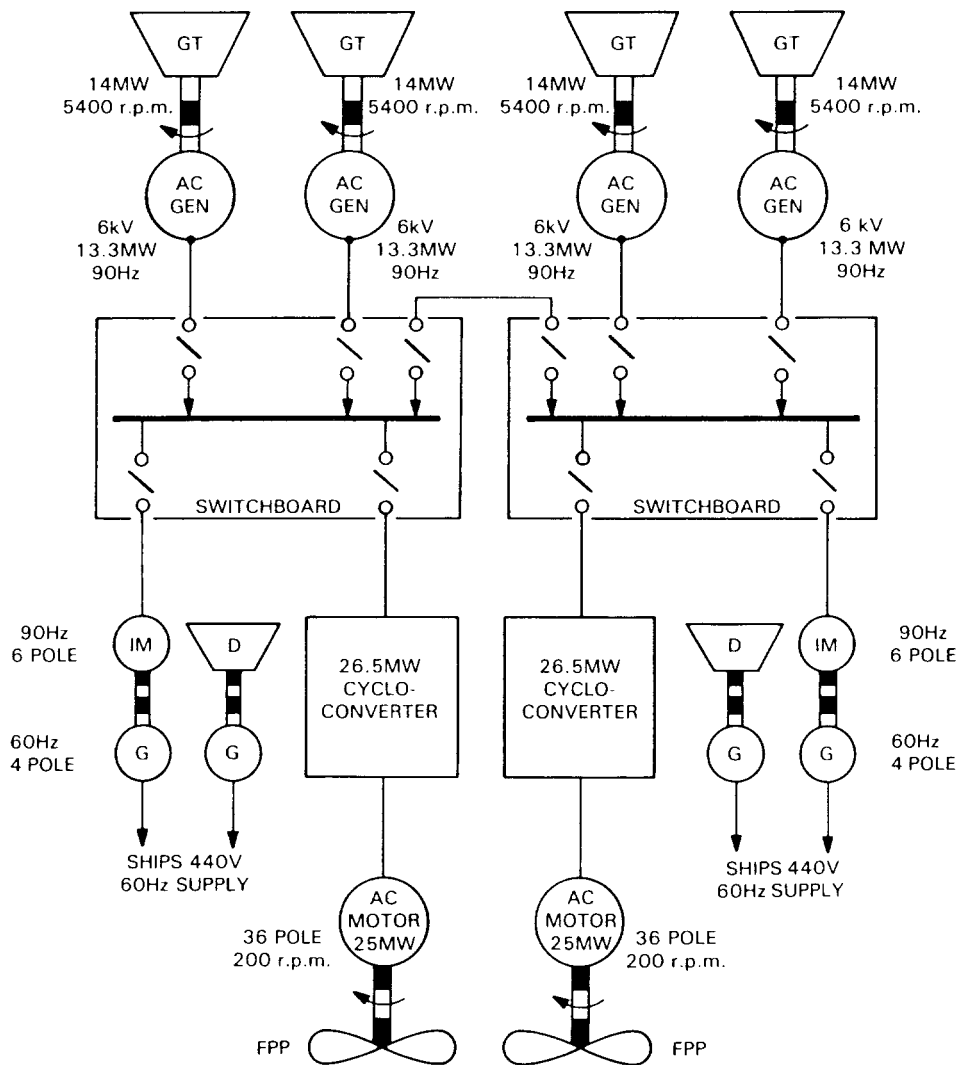

FIG. 5—WARSHIP ELECTRICAL PROPULSION SYSTEM  
From Sherlock & Borman<sup>1</sup>

There is also flexibility in another sense—flexibility of use of prime movers. Sherlock & Borman<sup>1</sup> illustrate this point well in their paper presented at an Institute of Marine Engineers conference on electrical propulsion for ships. They describe the comparison of an electrical propulsion system for a warship (FIG. 5) with an equivalent mechanical system (FIG. 6). The electrical system allows a single prime mover to power both shafts. The mechanical system must run two prime movers to power both shafts. It can of course trail a shaft but this is likely to give a noise penalty. In the area of ship service power the mechanical system requires four generators against the two + two motor generators of the electrical option. Sherlock & Borman then analyse how each system would perform against a standard operating profile for the type of ship. The results are reproduced in FIG. 7a for the electric drive and

FIG. 7b for the mechanical. The conclusion drawn from this comparison is that the electrical system can run on one gas turbine for 83% of its operating time whereas the mechanical system is only able to manage on a single gas turbine for 46% of its operating time (and then with the penalty of a trailing shaft). The reduced use of gas turbines in the electric ship then leads to a considerable saving in fuel consumption over a year.

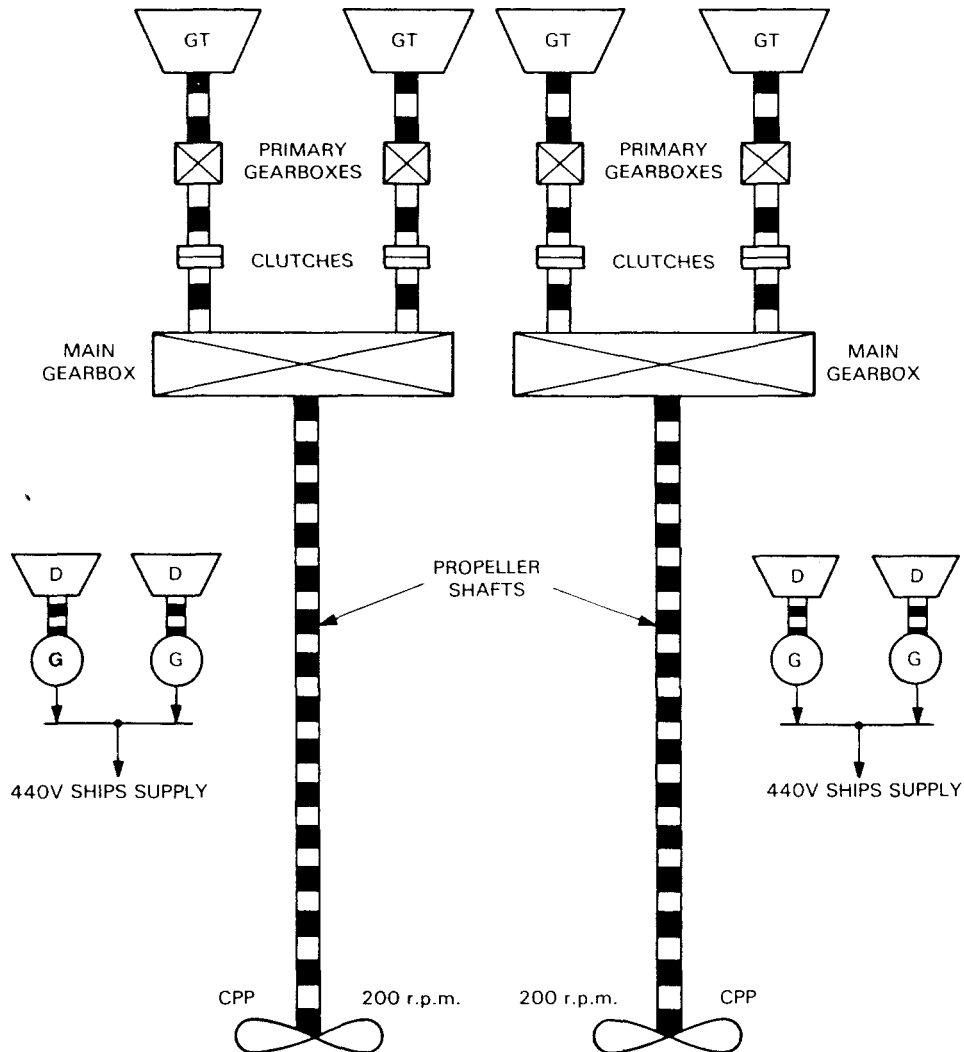
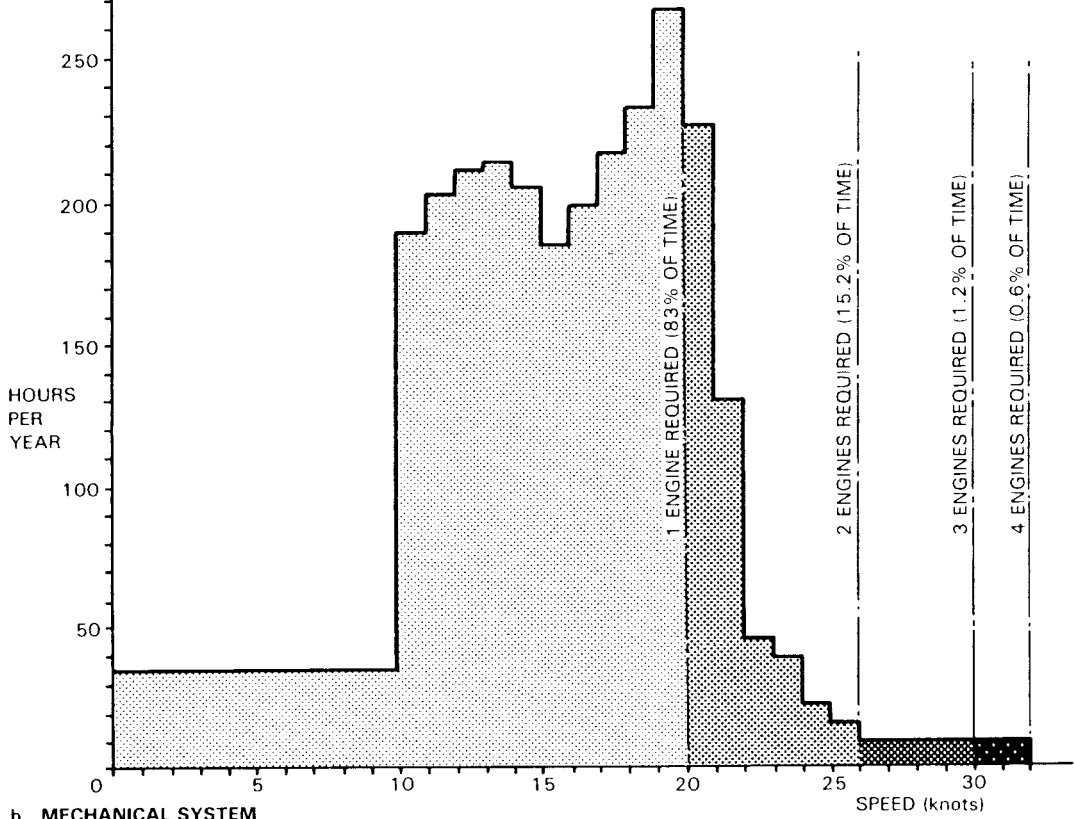

FIG. 6—WARSHIP MECHANICAL PROPULSION SYSTEM  
From Sherlock & Borman<sup>1</sup>

A couple of things need to be said about this study. Firstly the electrical system described, although perfectly feasible, would involve significant developments on systems available today. The mechanical system, in contrast, contained only elements that are fully proven. Secondly, the figures are only true for the particular operating profile chosen and perhaps, given another profile (particularly one biased towards the high speed end), the mechanical system would fare better. This said, the point that should be taken from the paper is that, given the right operating profile, electrical propulsion systems can provide greater redundancy and lower fuel costs over the year's running than comparable mechanical systems.

a. ELECTRICAL SYSTEM



b. MECHANICAL SYSTEM

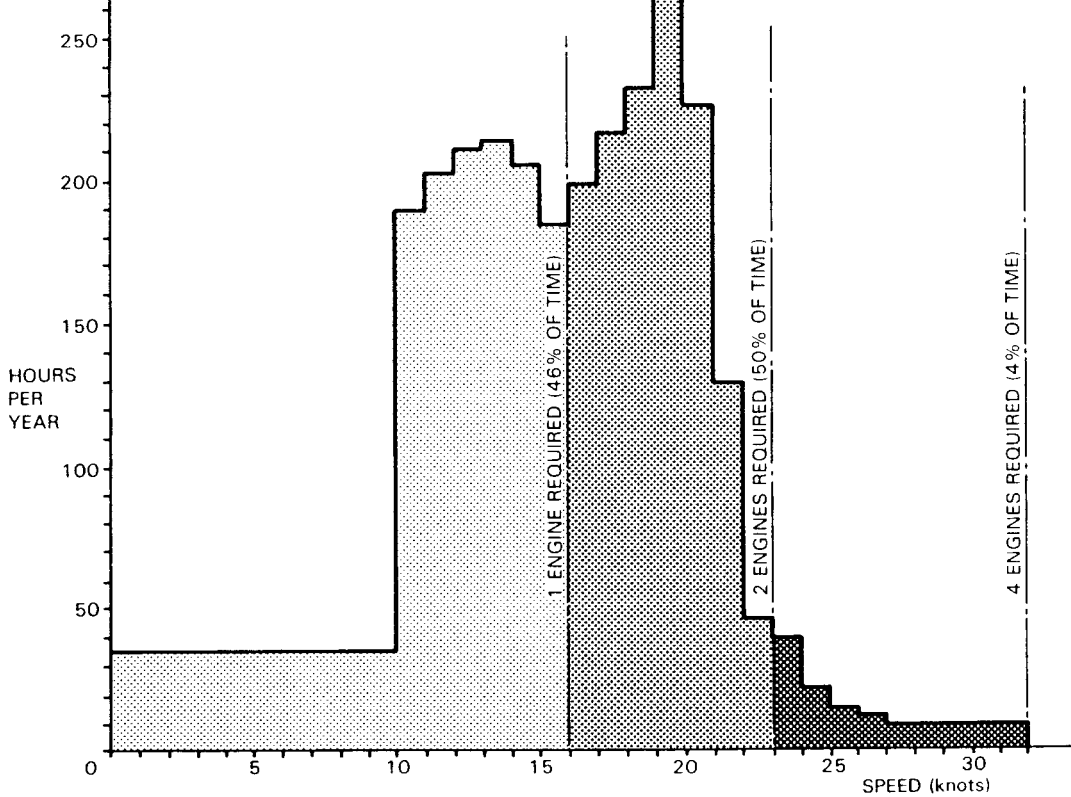

FIG. 7—SHIPS' OPERATING PROFILES, SHOWING SPEEDS ATTAINABLE WITH VARIOUS ENGINE COMBINATIONS; BASED ON 3000 HOURS TOTAL SEA TIME PER YEAR  
Source: NAVSEC Code 6144B

### Low Noise

FIG. 8 provides a comparative illustration of the lead in noise performance that diesel electric propulsion had over other propulsion systems at the time when the Type 23 was being designed. This position has not greatly changed. What is likely in the future is that target noise levels will become ever lower, even for such vessels as LPDs and AORs. This will tend to push any assessment of options in the future towards electric propulsion.

### High Auxiliary Loads

Vessels such as R.F.A. *Diligence*<sup>2</sup> and H.M.S. *Challenger*<sup>3</sup>, because of their specialist roles, have a very high requirement for electrical power at sea when not under way. This arises from loads such as thrusters, winches and cranes. The total auxiliary power requirement can sometimes be of the same order as the propulsion power requirement. It then makes sense to exploit the fact that the peak auxiliary load occurs when the propulsion load is low (and vice versa) by having an integrated propulsion and ships service electrical system.

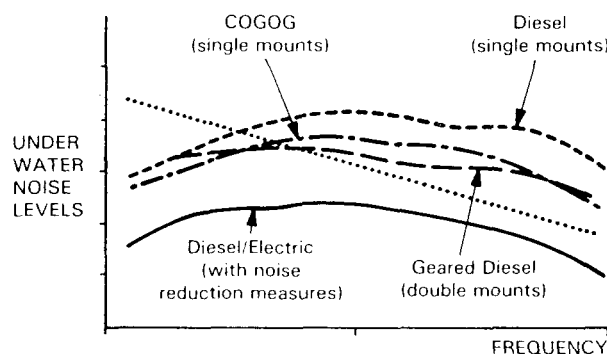

FIG. 8—RADIATED UNDERWATER NOISE LEVELS OF TYPE 23 PROPULSION OPTIONS AT SPEEDS BELOW CAVITATION INCEPTION (DOTTED LINE IS TARGET LEVEL)

### Electrical Propulsion Systems in Service and Design

Having looked at the reasons why electrical propulsion should be used I want to say a little about systems in service or in design.

The very first use of electrical propulsion in the Royal Navy was in the *Holland I* submarine. Today, within the R.N. the majority of electrically propelled vessels are still submarines.

The OBERON and PORPOISE Class submarines have a propulsion system consisting of two diesel generators, two main batteries and two 2.2 MW double armature main motors each driving one shaft. The main motors have to cope with a d.c. system voltage varying in a ratio of 2.25:1 dependent on the state of charge of the battery. Speed control of the motors is achieved coarsely by changing armature voltage and finely by trimming field current on the shunt field. The change in armature voltage is achieved by connecting the four armatures and two batteries in different series/parallel arrangements so as to alter the voltage applied to each armature. The bottom speed group has all four armatures connected in series; these are then in parallel with both batteries. For the top speed group all armatures are in parallel, with the voltage of the two series connected batteries applied to each.



The Type 2400 submarine propulsion system has not greatly departed from the control principles of the OBERON Class. The main differences result from the use of a single double-armature main motor, supplying at 4 MW, just under twice the power of the OBERON motors. The number of permutations of series/parallel arrangement with two batteries is therefore reduced by one and the 'groups' actually employed are shown schematically in FIG. 9. The slow speed group has replaced what was known as 'shafts-in-series' in OBERON—a graphic expression for the arrangement of all four armatures of both motors in series. The slow speed drive here is a Ward-Leonard system, with a motor generator supplying only the forward armature. The origin of the terms 'group-up' and 'group-down' for the middle speed groups goes back to the days of pre-OBERON submarines when the changing of groups was performed by large 'knife' type switches with two positions—'up' and 'down'. The successors to these knife switches in Type 2400 are cam-operated contactors which serve the same purpose and are housed in a propulsion switchboard mounted

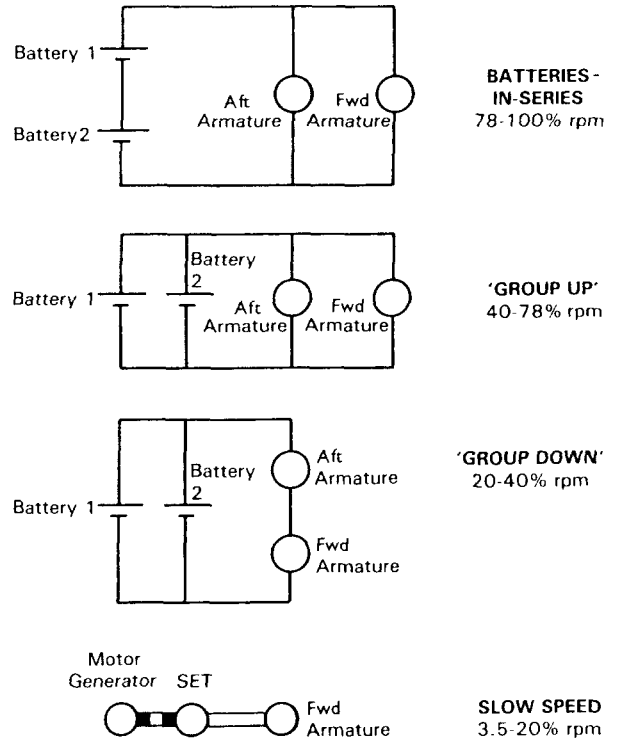

FIG. 9—'GROUPING' OF TYPE 2400 SUBMARINE PROPULSION SYSTEM

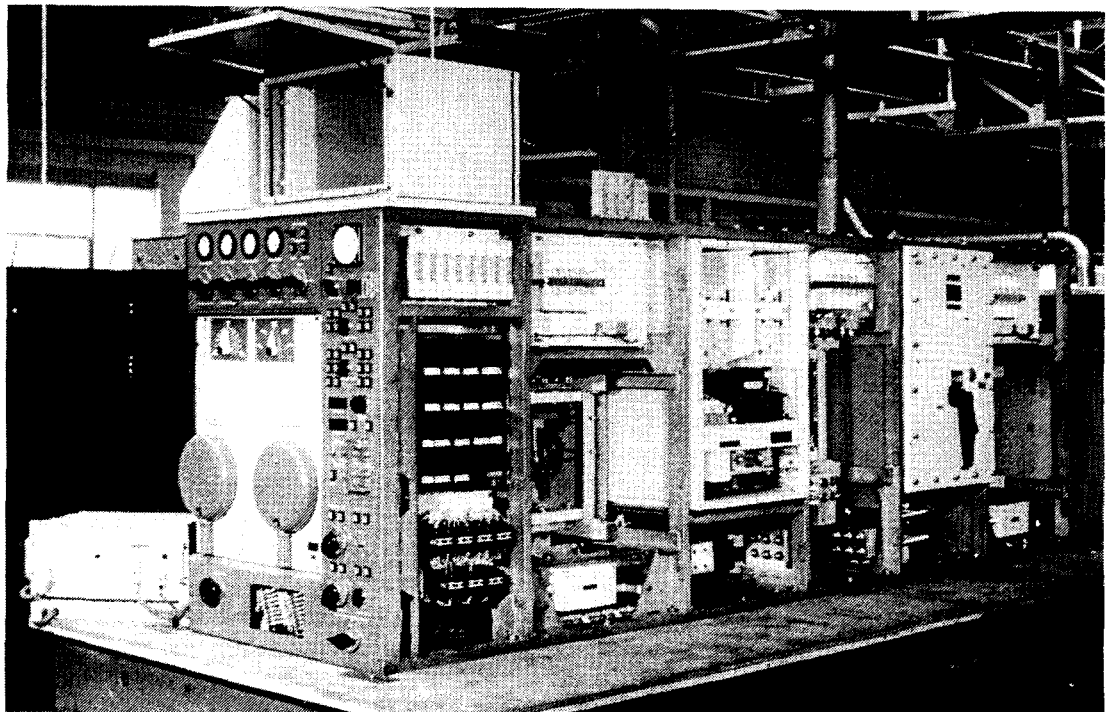

FIG. 10—TYPE 2400 PROPULSION SWITCHBOARD, SHOWING AUTOMATIC CONTROL UNIT (NORMALLY MOUNTED ON TOP OF SWITCHBOARD) IN LOWER LEFT-HAND CORNER

on top of the main motor. The switchboard is shown in FIG. 10. Besides the contactors for grouping and reversing it contains others for starting both armatures. The grouping and starting contactors are operated by cams on two camshafts, normally motor-driven but capable of hand operation in a fall-back mode. The box of electronics shown out of its case in the lower left of the picture controls the sequencing of grouping and starting and allows control of propulsion to be remote in the control room. The switchboard also contains two breakers for fast automatic isolation of major electrical faults.

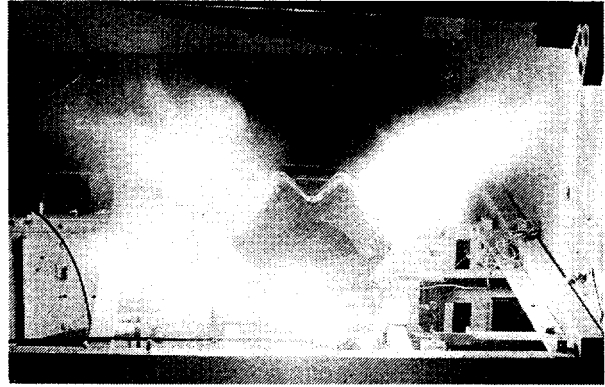

FIG. 11—TYPE 2400 CAM-OPERATED CONTACTOR ON THROUGH-FAULT TEST AT RAE WEST DRAYTON

In common with all conventional submarine d.c. systems the prospective fault levels in the Type 2400 are massive and the design of switchgear to cope with them, whilst at the same time fitting within a compact switchboard, has been one of the most challenging aspects of the system design. The testing along the way has been sometimes quite spectacular as FIG. 11 bears witness. This is an early version of a cam-operated contactor failing a through-fault test at some forty thousand amps. The interaction of self-induced magnetic field with this huge current has here led to moving and fixed contacts being forced apart, causing an arc to be drawn. The cure lay in achieving higher contact pressures so that the problem can only occur above the maximum possible current level.

The design of breakers to rupture prospective fault currents of over one hundred thousand amps without excessive damage is also far from simple. At this level of current there is a highly complex interaction of electromagnetic and thermodynamic forces within the breaker. The breaker design must take

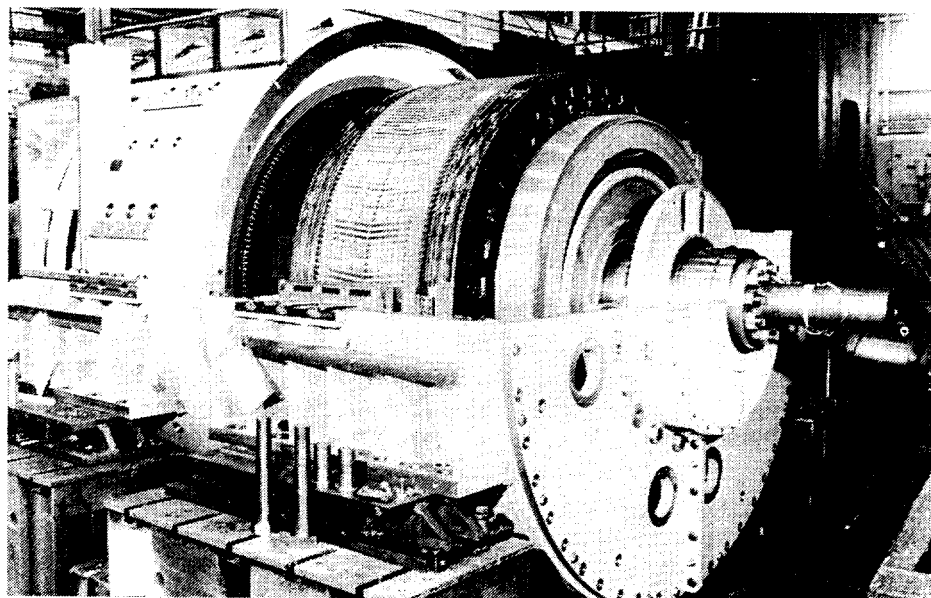

FIG. 12—TYPE 2400 MAIN PROPULSION MOTOR

this into account, harnessing both to achieve the aim of drawing an arc, expanding, cooling and extinguishing it, all within less than 20 milliseconds, so limiting the current to well below its prospective value.

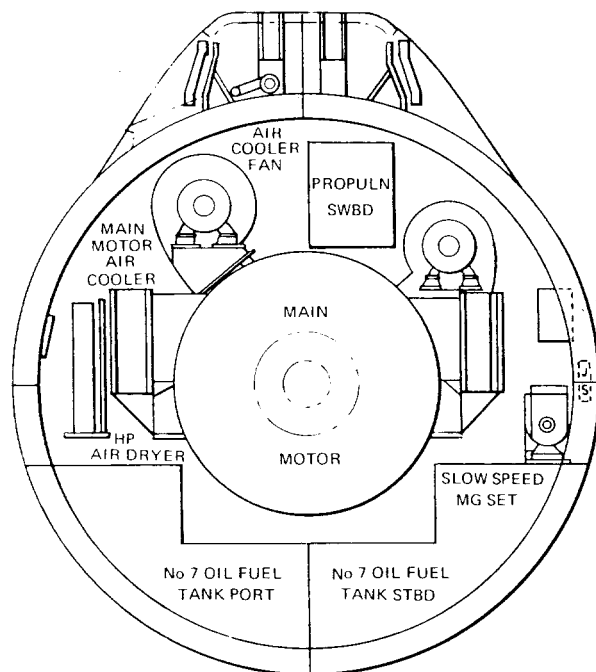

FIG. 13—TYPE 2400 MAIN PROPULSION MOTOR  
INSIDE SUBMARINE HULL

The motor that is controlled by all the switchgear is shown in FIG. 12. This is, at over 80 tonnes, the largest motor ever to go into a R.N. vessel. FIG. 13, showing it in relation to the submarine hull, gives some scale. The large size of the motor is attributable to the requirement to deliver its 4 MW at less than half the r.p.m. of the OBERON motors. Measures taken to reduce the noise signature have also pushed the size up somewhat and the traditional use of field weakening for speed control over a wide range also incurs a weight penalty.

All nuclear submarines currently in service or planned for service in the R.N. have some form of electrical propulsion as an auxiliary drive. The purpose of this emergency drive is to provide propulsion on temporary or sustained loss of reactor power. Under these

conditions power comes from a battery and one or more d.c. generators. A retractable azimuthing (i.e. steerable) a.c. motor drive is available if the main shaft is out of action.

VALIANT and RESOLUTION Class submarines have a single shaft line mounted emergency d.c. motor which is shunt field controlled and has its armature connected directly across the battery. In the later SWIFTSURE and TRAFALGAR Classes a high speed d.c. motor is used which drives into the aft end of the gearbox by chain drive. The use of the high speed motor allows a large reduction in size and weight for the same power output. TRIDENT will have a similar arrangement to SWIFTSURE and TRAFALGAR.

Turning to surface ships, there are as yet few electrical propulsion systems. The oldest of these is that fitted in HECLA Class survey ships. A schematic diagram of this system is given in FIG. 14. This system employs a constant current d.c. loop, the principle being that the armatures of all machines are connected in series. The speed of the motors in the loop is controlled by adjusting their shunt field current. The fields of the generators in the loop are adjusted so that the sum of their generated voltages exceeds the sum of motor back-e.m.f.s. by the amount required to circulate the constant current. The system is simple, rugged and has served well over the last 20 years. R.M.A.S. *Newton* is a special purpose oceanographic trials ship of 1976 vintage employing a similar, but updated version of the *Hecla* system. Machines in these vessels do not use circuit breakers in the conventional sense but transfer switches which connect them into the loop or take them out—without breaking the loop.

*Hecla* and *Newton* illustrate the use of electrical propulsion because of high auxiliary load whilst propelling at slow speeds. More modern examples are H.M.S. *Challenger* and R.F.A. *Diligence*. Both these vessels use a.c. rather than d.c. and at much higher voltages than the standard 440 V,

3.3 kV for *Challenger* and 6 kV for *Diligence*. Higher voltages are necessary in these high power systems to keep currents down and hence equipment smaller, and to make fault levels manageable. More detail on these ships is available<sup>2, 3</sup>.

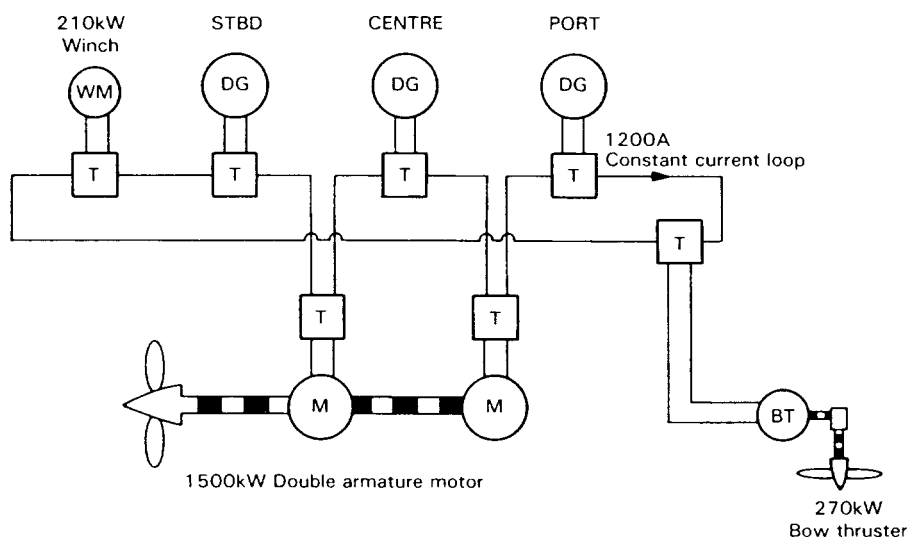

FIG. 14—'HECLA' CLASS SURVEY VESSELS PROPULSION SYSTEM

DG: diesel generator  
T: manual transfer switch

Regular readers of this *Journal* will know a good deal about the Type 23 frigate electrical propulsion<sup>4, 5, 6</sup>. The d.c. motor used in this system is considerably less of a control problem than for a conventional submarine because speed control can be done entirely by armature voltage control throughout most of the range. This is more satisfactory than field control because it leads to faster response times. Also the ability to develop maximum power at full field rather than minimum field leads to a smaller motor. The Type 23 motor only uses field weakening when the gas turbine is running, at speeds above its normal full load speed. By this device the motor can continue to contribute its full power output to the shaft right up to maximum r.p.m. on the gas turbine.

The other new construction project utilizing electrical propulsion is the Single Role Mine Hunter<sup>7</sup>. The justification for its use here is really a combination of noise requirements and flexibility of arrangement.

### The Future

Looking towards what we might be doing with electrical propulsion into the next decade and beyond there are four main areas of MOD interest: liquid cooled motors, noise reduction, a.c. systems, and super-conducting machines. These are all aimed towards either reducing the disadvantages of electrical propulsion or enhancing the present advantages.

#### Liquid Cooling

In order to get down the size and weight of an electric motor it is necessary to design the machine to make better use of the iron and copper within its magnetic and electric circuits respectively. The use that a machine makes of these materials is measured by a utilization factor which is proportional to the product of the magnetic flux density in the machine air gap and the current density within the windings of the machine. It is these two quantities that must be increased if machine size and weight are to come down.

Worthwhile improvements in air gap flux density can be achieved, in theory at least, by the use of the better magnetic steels, and this looks to be worthy of exploration.

Significant increases in current density within the electrical circuit are achievable by the use of liquid cooling. The idea is to provide a direct heat transfer path from the conductors to the cooling liquid. In air cooled machines the heat path is from the copper through several layers of electrical insulation to the steel of the machine and thence to the air. With a liquid cooled machine the coolant is directly in contact with where the heat is generated. There are of course problems. FIG. 15 illustrates one: if we improve the cooling and thus reduce the amount of copper in the machine we put up the electrical resistance and hence incur higher  $I^2R$  losses, thus decreasing efficiency. This is likely to limit the use that can be made of liquid cooling for conventional submarine motors since we would not wish to sacrifice hard-won improvements in battery capacity. More practical problems also have to be solved, mainly associated with the 'plumbing' of the cooling system to achieve sensible reliability and shock resistance.

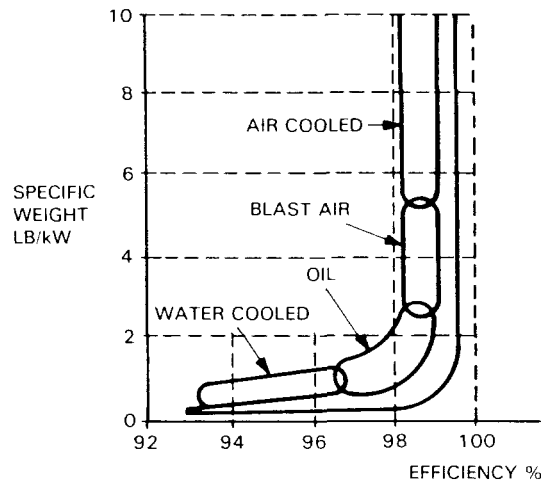

FIG. 15—EFFICIENCY OF VARIOUS COOLING METHODS

### Noise

As was said earlier, noise is currently an area where electrical propulsion has an advantage over other transmissions. Work is continuing to extend this advantage and improve what is still a hazy understanding of the mechanisms that lead to noise in electrical machines. Studies in this area involve the analysis and understanding of extremely complex electromagnetic forces acting on equally complex mechanical structures. Progress is slow and is only achievable by the use of large computers running powerful finite-element analysis programs.

The difficulty of predicting noise levels from theoretical study has led to interest in practical studies and in particular to a desire to study the noise levels associated with a.c. electrical propulsion. To this end it is hoped shortly to be able to carry out on-board measurements of merchant vessels already using a.c. electrical propulsion. The lack of any data on the noise performance of a.c. systems has been a long-standing problem. In the early days of the Type 23 frigate design an a.c. propulsion motor was an option rejected because of ignorance of its noise performance.

### a.c. Systems

FIG. 16 illustrates the possible types of electrical propulsion system. The variable speed prime mover and variable speed motor combination was used in S.S. *Canberra* and on many vessels before her with great success. However, the need for a common frequency between generator and motor leads to difficulties with the design of both if they are to match the very low propeller r.p.m. required in modern warships. Also this system makes impractical the use of an integrated electrical supply and propulsion system with all its potential advantages. We are therefore more interested in fixed speed prime-

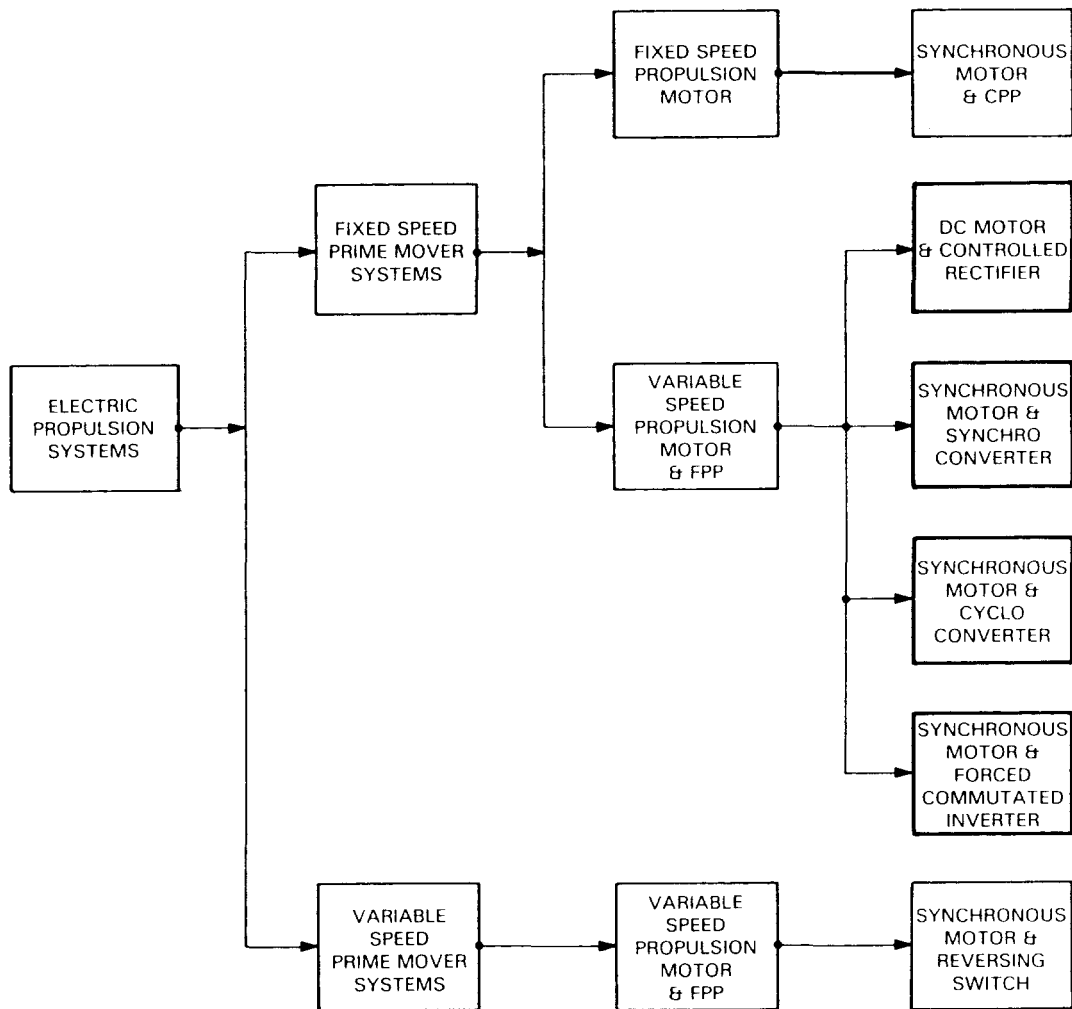

FIG. 16—ELECTRICAL PROPULSION SYSTEMS  
Based on Sherlock & Borman<sup>1</sup>

mover systems. The fixed speed a.c. motor with a gearbox and CPP is used in R.F.A. *Diligence*. It is about the cheapest option since it allows the use of small high speed induction motors driving into a combining and reducing gearbox. This is a good system for long periods of high speed running. It is not really suitable for warships because of a relatively poor noise performance.

The viable systems for warships therefore come down to the four in the fixed speed prime mover variable speed motor class. These systems are shown diagrammatically in Figs. 17 to 20.

FIG. 17 is the Type 23 frigate configuration using a d.c. motor. The limit on the size of d.c. motor that can be produced is set by the ability to achieve satisfactory commutation. The approximate rule of thumb for commutation limits is:  $PN = 1.5 \times 10^6$ , where P is kW and N is r.p.m. At 200 r.p.m. this allows 7.5 MW per armature, i.e. 15 MW for a double armature d.c. motor. If we want an all electric (not just cruise propulsion) ship of 20 MW per shaft (at 150 r.p.m.) we therefore need to go for an a.c. system. Even at lower power levels the ability to dispense with commutators and brushgear makes a.c. systems attractive.

What sort of a.c. drives are possible? FIG. 18 shows a Synchro-Converter drive. In crude terms this converter consists of two bridges, one of which rectifies the generated a.c. to provide d.c. The d.c. is smoothed by the line









