

# A DIGITAL MARITIME INTEGRATED INTERNAL COMMUNICATION SYSTEM

## RICE 10

BY

EUR ING J.R.LISTER BSC CENG MIEE RCNC  
(*Director General Fleet Support (Equipment and Systems)—ES265*)

AND

J.D.ROSIE BSC CDIPAF CENG MIEE  
(*Redifon SPT, Crawley*)

### ABSTRACT

The article provides a description of RICE 10, the Royal Navy's first digital internal communications system. Special attention was paid to system performance during the technical requirement preparation contract negotiation and the subsequent design phase. During its development, a high priority was given to:

- Interface definition.
- Environmental performance.
- System intelligibility.
- User acceptance.
- Introduction into service.
- Equipment reliability.
- System robustness.
- Through life support costs.

Within the Royal Navy, internal communications can no longer be treated as a range of equipment interconnected by cabling.

### Introduction

The Royal Navy has for some time been cautious in its application and deployment of digital technology to voice communication equipment. The RICE 10 system now entering service has utilized user experience of current in service equipment and benefits from the recent evolution in coding techniques and standards.

Traditionally, separate internal communications equipment have been interconnected to provide essential communication services. These services enable a platform to move, float and fight; a basic necessity for naval platforms. Digital technology and the move towards integrated communication systems demand a thorough user specification and a system approach from the outset.

### Background

The application of digital technology to Royal Navy primary internal communications systems was driven by the need to:

- (a) Improve system resilience.
- (b) Reduce installation and through life support costs.

Within RICE 10, main broadcast and ships' alarms are totally integrated into the primary system. The use of modern technology brings with it significant benefits and enhanced facilities for the user and maintainer. A user is now able to relocate an operating position and transfer his personal communications set-up to a new position. In addition, the system communication schedule can be

re-configured without recourse to hardware or cabling modifications. Such relocation and reconfiguration of facilities are instantaneous. RICE 10 uses a fully meshed network that has inherent redundancy to minimize vulnerability to defects and action damage.

## System overview

### *System facilities*

RICE 10 provides all the system facilities required by a modern internal communication system. The user is provided with all required functions from an operator terminal, called an *Outstation*. By selecting the required facility using front panel function keys, the user may select:

- A person-to-person *Interphone Call*.
- One-to-many *Broadcast Call*.
- One-to-many *Group Line* or *Intercom*.

This new system overcomes limitations of traditional systems, in particular the holding of the *Communication Schedule* in memory and the use of high speed digital multiplexing techniques to reduce the quantity of cable required. Significant functional improvements include:

- The possible relocation of outstation facilities.
- System re-configuration.
- System tolerance to damage.
- Integration of broadcast and alarm functions.

### *The network*

RICE 10 consists of a mesh network of intelligent processing and routing switches called nodes. This network carries multiplexed digital voice and system data at 8.192 Mbps using four 2.048 Mbps data links between each node. The network can consist of up to 64 nodes and a mesh configuration is produced by each node connecting to a maximum of three other nodes.

A node controls the flow of system data passing packages of information on to adjacent areas for use or forwarding as appropriate. Each node can serve up to 15 operator voice terminals (outstations) or interface units up to an overriding system maximum of 512. The RICE 10 nodes transmit high speed serial data over fixed wire connections with all data links operating at the same basic data rate of 2.048 Mbps. Between two nodes there are four separate two way serial circuits, between a node and an outstation there is one.

A basic 4 node RICE 10 mesh is illustrated in (FIG. 1). This figure shows the inherent signal path redundancy resulting from the multiple connections between nodes. In this configuration there are five alternate paths between any two nodes.

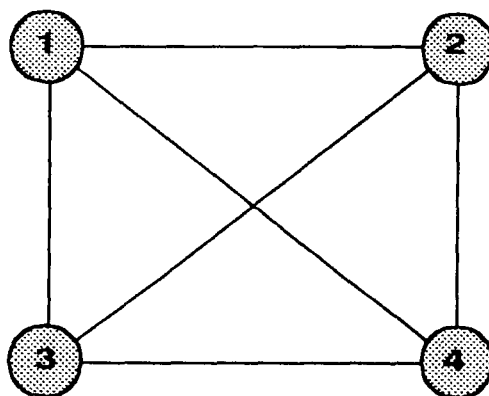

FIG. 1—A FOUR NODE RICE 10 NETWORK

As the number of nodes in a system increases, so do the permutations of paths through the mesh. The node network dynamically selects the quickest available route through the network for *Interphone* (person-to-person) voice data. This route is determined by a system routing algorithm and will generally be the shortest data path between the two outstations and will automatically take into account any system damage.

If the node location and inter-nodal cable routing are correctly planned, the resulting mesh layout has a very high resilience to battle damage or operational failure. A six node RICE 10 system layout is shown in (FIG. 2). This system could feed a maximum of 90 outstations, although in practice some of the node control ports would connect via interfaces to external equipment or sub-systems, e.g. Telephone Exchange.

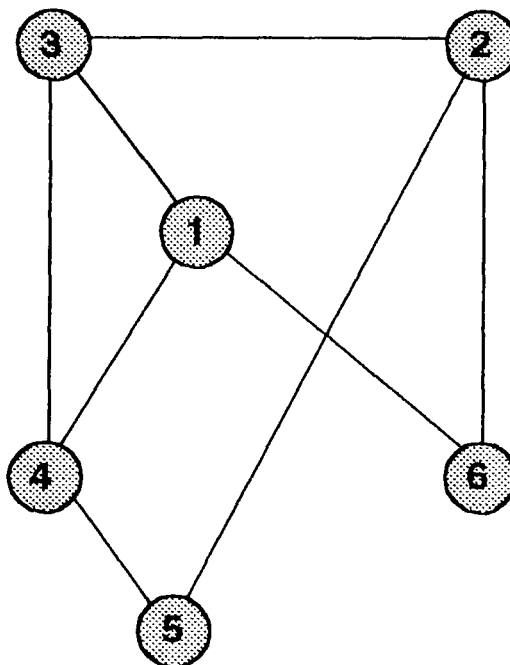

FIG. 2—A SIX NODE RICE 10 NETWORK

## The system hardware

### *The node*

A node may be considered similar to an electronic telephone exchange interconnected to others in a similar manner to the public switched telephone network. A node consists of a bulkhead mounted housing (FIG. 3), containing two adjacent mother boards and a number of Panel Electronic Circuits (PECs) which are described below. A block diagram of the RICE 10 node is shown in (FIG. 4).

### *Conference bridge*

RICE 10 provides a conference facility which provides for a multiple number of talkers and listeners on the same voice channel. This facility is provided by the node conference bridge module.

The conference bridge PEC uses a novel technique to sample data from up to 15 outstations and the three other connected nodes to select the highest instantaneous level for each *Intercom* or *Group Line* channel. This data sample is then routed to the next node in the network conference chain.

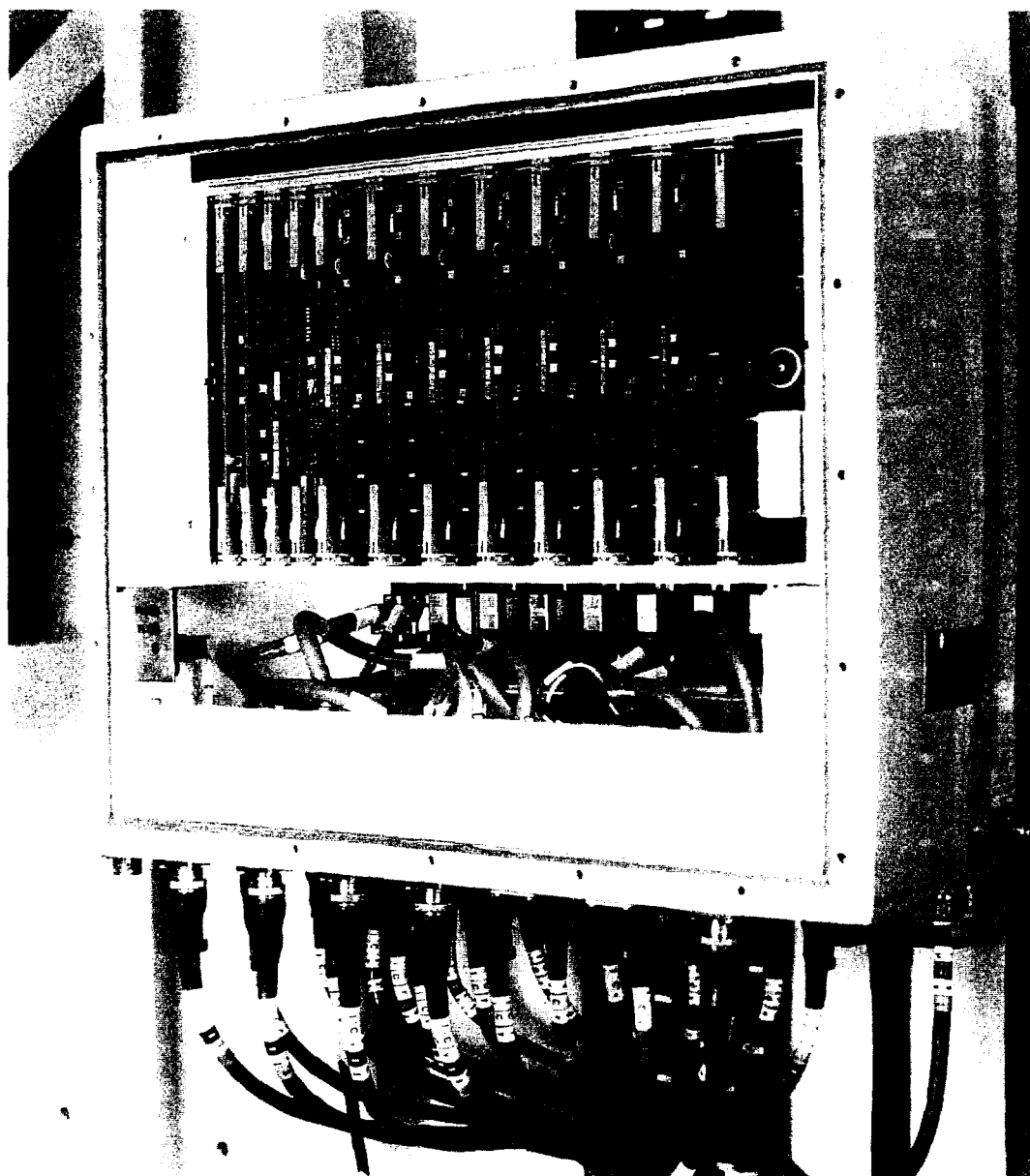

FIG. 3—RICE 10 INSTALLED AT THE TYPE 23 SDF

Using this technique, audio signals are switched between the different active sources to produce a single composite output. This system has the advantage that only one talker provides a contribution at any point in time. This is unlike traditional analogue systems that get progressively noisier as more users join the group due to the addition of circuit noise from each user terminal.

#### *Timing and Built in Test Equipment (BITE)*

The timing, BITE and tone generator PEC provides a local data clock for the node. When the node is not the system master, the data clock is regenerated from a selected node link to enable all nodes to be synchronous with a single *Master* node. This use of a sequential series of regenerated data clocks produces a *plesio* or *near* synchronous system. This module also provides a freely running data clock for when the system is being set up or when the node is acting as the timing master.

The BITE controller on this PEC continuously interrogates the other node boards, collates fault information and passes this to the node processor. System fault or damage information is then passed around the node network for reporting to a Maintainer's Console Unit (MCU) which is described in a later section.

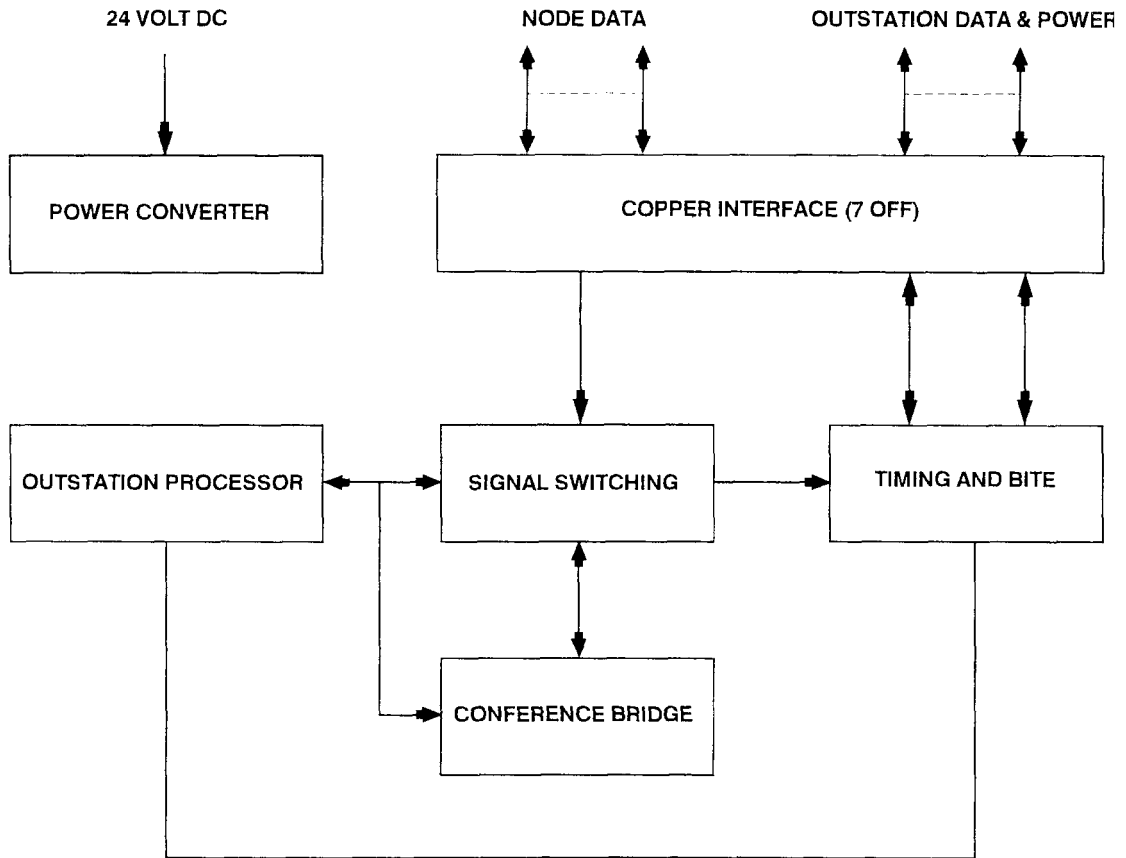

FIG. 4—FUNCTIONAL BLOCK DIAGRAM OF THE RICE 10 NODE

Outstation call progress tones and system alarm tones are also produced on this PEC.

#### *Signal switching*

Data going to and from a node is routed by the signal switching PEC under the control of the node processor. This data is passed to and from the other units using HDB3 (High Density Bi-polar of order 3) signalling. This is a bandwidth efficient data coding technique that allows for the regeneration of a data clock regardless of the data content.

#### *Copper interface*

Conversion between Pulse Code Modulation (PCM) and HDB3 signalling formats takes place in one of seven Time Division Multiplexing (TDM) copper interface PECs contained in each node. Each one of these interface-boards contains four two-way HDB3 circuits. Three of these boards are for inter-node use with each board connected to a single node. The remaining copper interface boards each connect up to four outstations or interface units to the node.

#### *Power converter*

The power converter PEC connects to a non interruptible power supply which provides a nominal 24V dc. This PEC provides the various power supply levels required for the other PECs in the node.

Each outstation is powered from the node 24V supply superimposed on the transmit and receive signal lines from the node interface PEC. Electronic protection circuits within the copper interface PEC ensure the outstation is protected from *Over Current* and *Over Voltage* fault conditions.

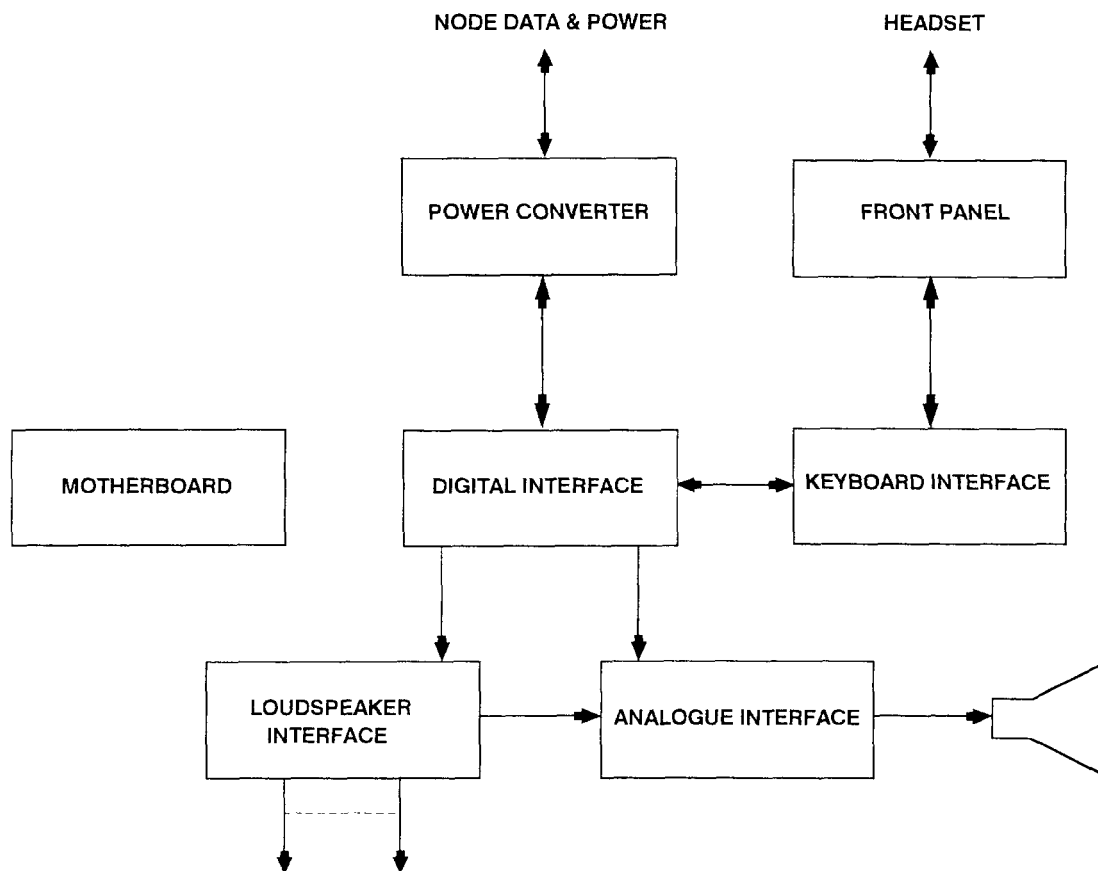

FIG. 5—OUTSTATION FUNCTIONAL BLOCK DIAGRAM

### *The outstation*

(FIG. 5) shows a functional block diagram of an outstation. The outstation provides the system facilities for an operator and may be equated to the individual subscriber unit connected to a telephone exchange. Up to 15 outstations may be connected to one node using any combination of 5 and 16 channel units (FIGS 6&7). An outstation consists of an electronics assembly that may be either bulkhead mounted, as a watertight assembly or as console mounted Versatile Console System (VCS) assembly. The assembly contains a motherboard into which are plugged a number of PECs.

### *Electronic assembly*

The electronics assembly (and its associated PECs) is a common item and can be interchanged among 5 and 16 channel outstations, watertight or VCS, without the need for customizing.

Each of the PECs in the outstation connects, as necessary, with the others via a single mother board. Main control of the outstation is carried out by the processor on the outstation digital interface board, in association with the processor on the outstation keyboard interface. A signal from the operator's microphone is received in the outstation by the outstation analogue interface, where it is digitally sampled and converted to PCM. Once in PCM form, it is passed to the outstation power converter where it is converted to HDB3 format and then transmitted to the node for routing to its final destination.

The outstation front panel uses a flat membrane keyboard to provide a tactile switching system easy to operate and clean. The removal of protruding switches also eliminates the potential maintenance problem of broken switch and control stems.

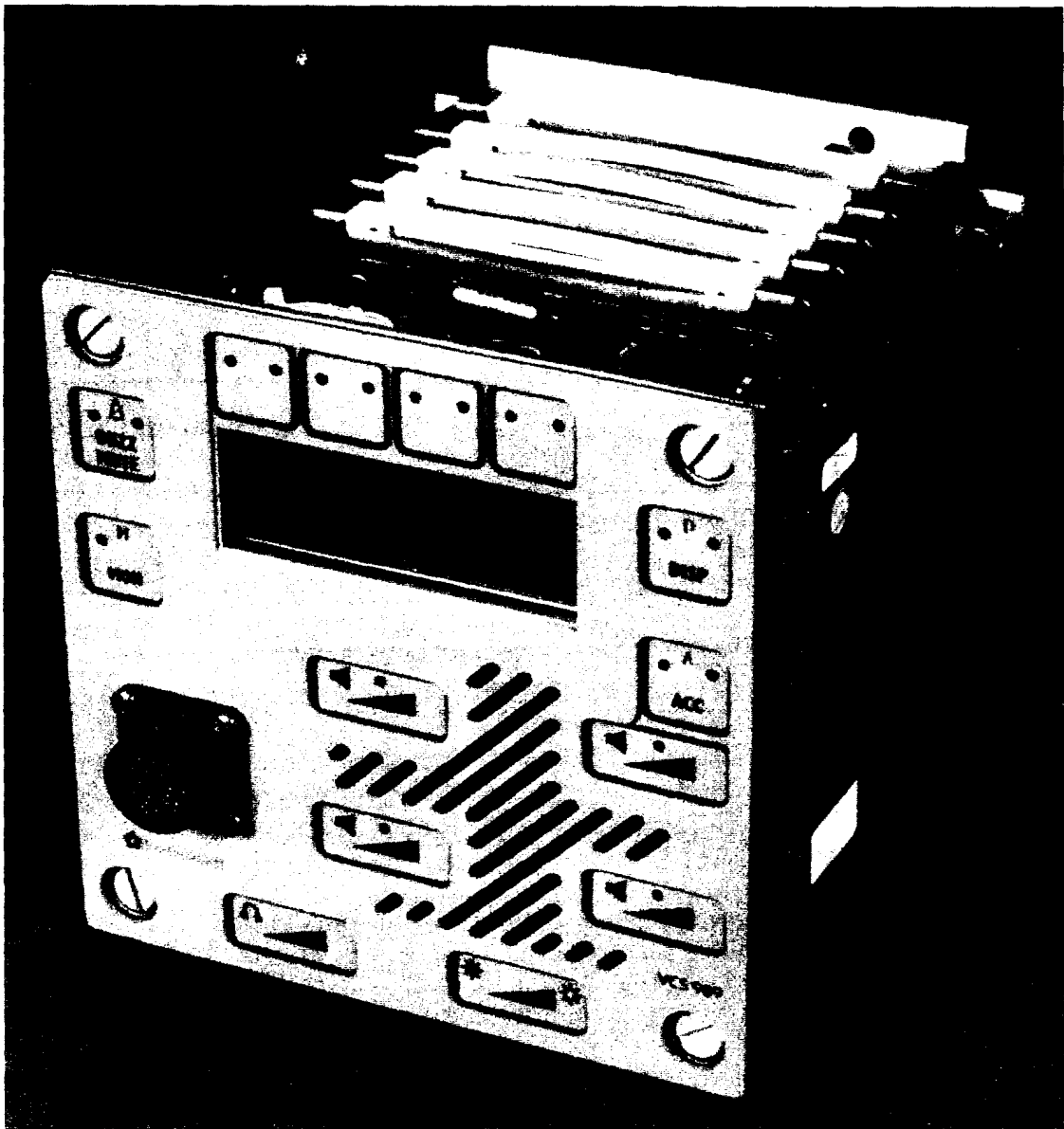

FIG. 6—FIVE CHANNEL RICE 10 OUTSTATION

### *The MCU*

The MCU is a rugged hand held portable computer that interfaces with RICE 10 by connecting to any of the node units. Modules in the RICE 10 system carry out continuous fault monitoring using BITE; any fault indications are passed through the node network to the MCU. The MCU logs and displays any fault reports it receives, alerting the maintainer to any reports by using an audible alarm.

When a RICE 10 system is deployed, it is anticipated that an MCU will be permanently connected to the system to provide continuous monitoring and a second MCU will be available to the maintainer for mobile use.

In addition to fault reporting and system interrogation facilities, the MCU also allows the maintainer to modify the ship's communications schedule. Using the MCU, a maintainer can also print the system communication schedule and all reported faults to assist with maintenance activities. This print-out includes a time and date record for all reported MCU messages to provide a full system log.

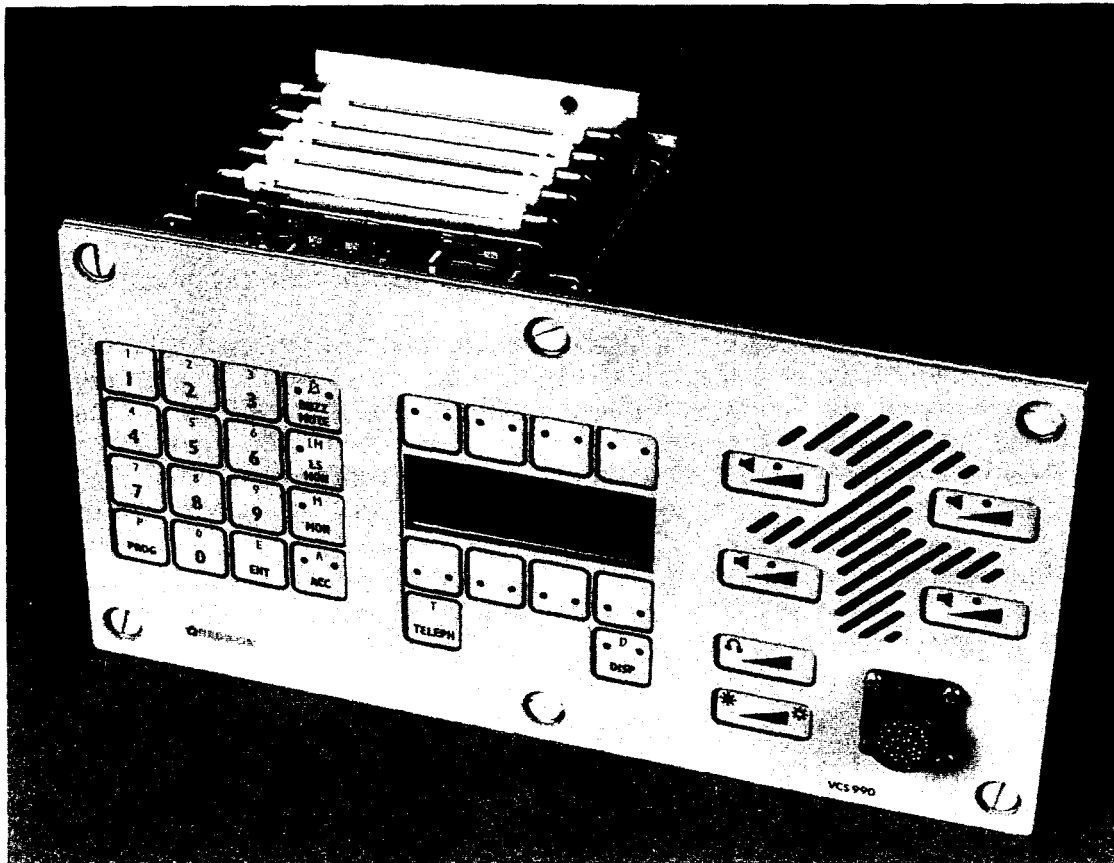

FIG. 7—SIXTEEN CHANNEL RICE 10 OUTSTATION

### *Main broadcast and alarms*

Operation Corporate revealed the vulnerability of existing main broadcast and alarm systems to battle damage. Existing in service systems typically use a centralized or dual high power amplifier rack feeding a loudspeaker system. RICE 10 has removed this inherent system weakness by eliminating the need for centralized amplifier systems. Main broadcast and alarm signals are distributed through the RICE 10 network and then amplified locally, either at the outstation or at adjacent low power amplifier and loudspeaker units. Using the RICE-10 network there are several ways that broadcast and alarm signals can be propagated thus providing protection against system damage.

### *Principles of data conversion*

For voice communication systems the basic speech wave-form characteristics must be preserved to ensure adequate intelligibility and voice preservation. Digital systems, such as RICE 10, convert continuous analogue signals into discrete data words and may use many different representations, for instance PCM, Delta Modulation (DM) and Differential PCM (DPCM) are some of the schemes used.

RICE 10 uses a companded PCM method to transmit speech as a digital data stream. This involves measuring the instantaneous value of analogue signals at regular intervals, transmitting each sample as a digital value, and then reconstituting the analogue signal from the digital samples at the receiving end. The use of a companded method means compression of the analogue signal to produce greater resolution for the smaller audio signals typical of the majority of voice data.



All systems which employ an analogue to digital conversion must consider Nyquist's Theorem that states:

"Any band-limited signal can be reconstructed from samples taken periodically in time if the sampling rate is at least twice the highest frequency of the signal."

RICE 10 transmits voice and alarm signals with a restricted bandwidth of 300Hz to 3.4kHz and samples at a rate of 8kHz. It uses an 8 bit data package to depict a single sample, which means that each voice sample is represented by a discrete number in the range 0 to 255. With a sample rate of 8kHz the voice information is transmitted as a digital stream of 8,000 x 8 bits per second producing a basic speech channel data rate of 64kbps.

If a digital voice network uses a faster data rate than 64 kbps, each data package is transmitted with a time interval between the end of one and the start of another. This time interval may be employed to transmit other sets of packages containing additional information. This interlacing of different signals within a repeated time slot is known as TDM. Data links within RICE 10 use a data rate of 2.048 megabits per second which is 32 times faster than that required for a single set of data packages, and therefore allows 32 separate sets of packages to be sent along one data link. Each set of different 8 bit packages within a data stream is referred to as a Channel with a time interval consisting of 32 consecutive channels referred to as a *Frame* (FIG. 8).

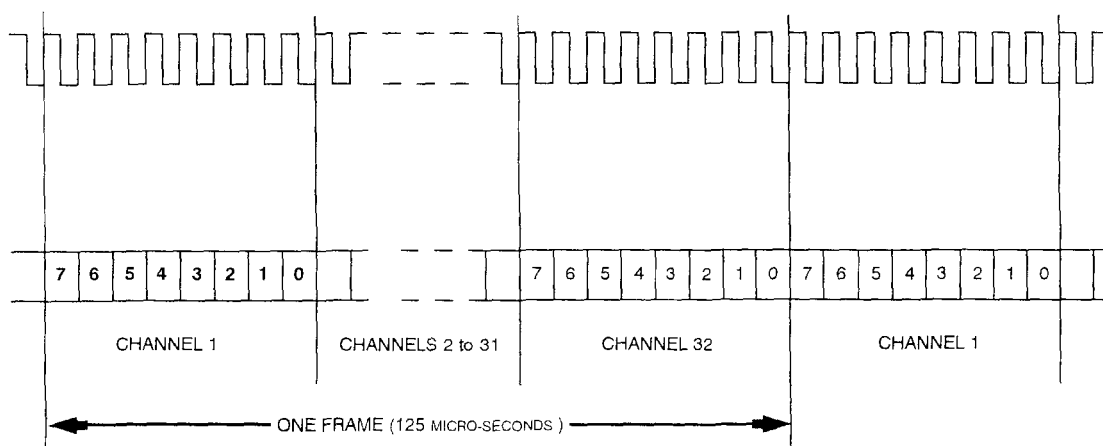

FIG. 8—TYPICAL DATA STREAM

Within the RICE 10 system, different data streams are travelling between the system elements each with 32 channel time slots per frame and all at the same data rate. A microprocessor within each node equipment controls these data streams, routing individual channels from one stream to another until they reach their destination.

## Interfaces

The RICE 10 design objective was to use the same ancillary equipment as RICE 2 and hence the user of RICE 10 will be using the same in service headsets and handsets. However, because RICE 10 is a digital system, some supporting sub-systems that interface with RICE 2 required specific interfaces to be developed.

The system interface diagram shown in (FIG. 9) shows the interconnection from a node to both sixteen and five channel outstations, as well as to the external peripherals via appropriate interfaces. For each connection there is a unique interface reference. Each external peripheral interface has a unique identity for which a range of standard interfaces has been developed.

The contractor was made responsible for identifying, defining, designing and managing these interfaces in accordance with Naval Engineering Standard (NES) 1013. Interface units were then manufactured installed and connected to a mini RICE 10 system before being connected to the Type 23 Shore Development Facility (SDF) at DRA Portsdown for the final demonstration phase.

The RICE 10 VCS units were mounted above the existing RICE 2E units at the SDF (FIG. 10). The RICE 2E units can be removed and replaced by the RICE 10 units at any future date decided by the Type 23 platform project. In the meantime the RICE 10 system continues to be used for system and interface trials.

## System design

Fundamental to a voice transmission network such as RICE 10 is the system ability to ensure all calls can be made. The failure of a system to transfer a call is known as *blocking*, since a user's call is effectively prevented.

Provided the system network has been correctly designed within platform constraints, RICE 10 will provide:

- A high degree of flexibility.
- Excellent non-*blocking* capability.
- A network redundancy that produces a high resilience to battle damage.

However, if the design of the mesh or connection to its power supply units is sub-optimal, the system may be vulnerable to damage or equipment failure.

### *Network design considerations*

RICE 10 provides a flexible network that can be configured to suit different platform constraints. It will generally provide a non-*blocking* system even with some damage to nodes or system data cables. However, the robustness of RICE 10 to damage or equipment failure depends on the topology of the node network employed.

It is a complex voice communication system and each different platform to utilize RICE 10 will require a new system design. However, a robust and cost effective design is easily achieved, provided the facility is treated as a system and some basic design rules are followed.

### *Network design evaluation*

The RICE 10 network supports a *plesio synchronous* data system, that requires the regeneration of a data clock from a single system master. This clock regeneration method leads to layers within the network where nodes further from the master node have a larger number of sequential data link connections to the master. In an ideal RICE 10 network, the number of system *data layers* should be minimized.

The potential resilience to damage of a RICE 10 system may be analysed in terms of the minimum number of inter-nodal data links required to connect any node with each of the other nodes. The more links required, the more vulnerable

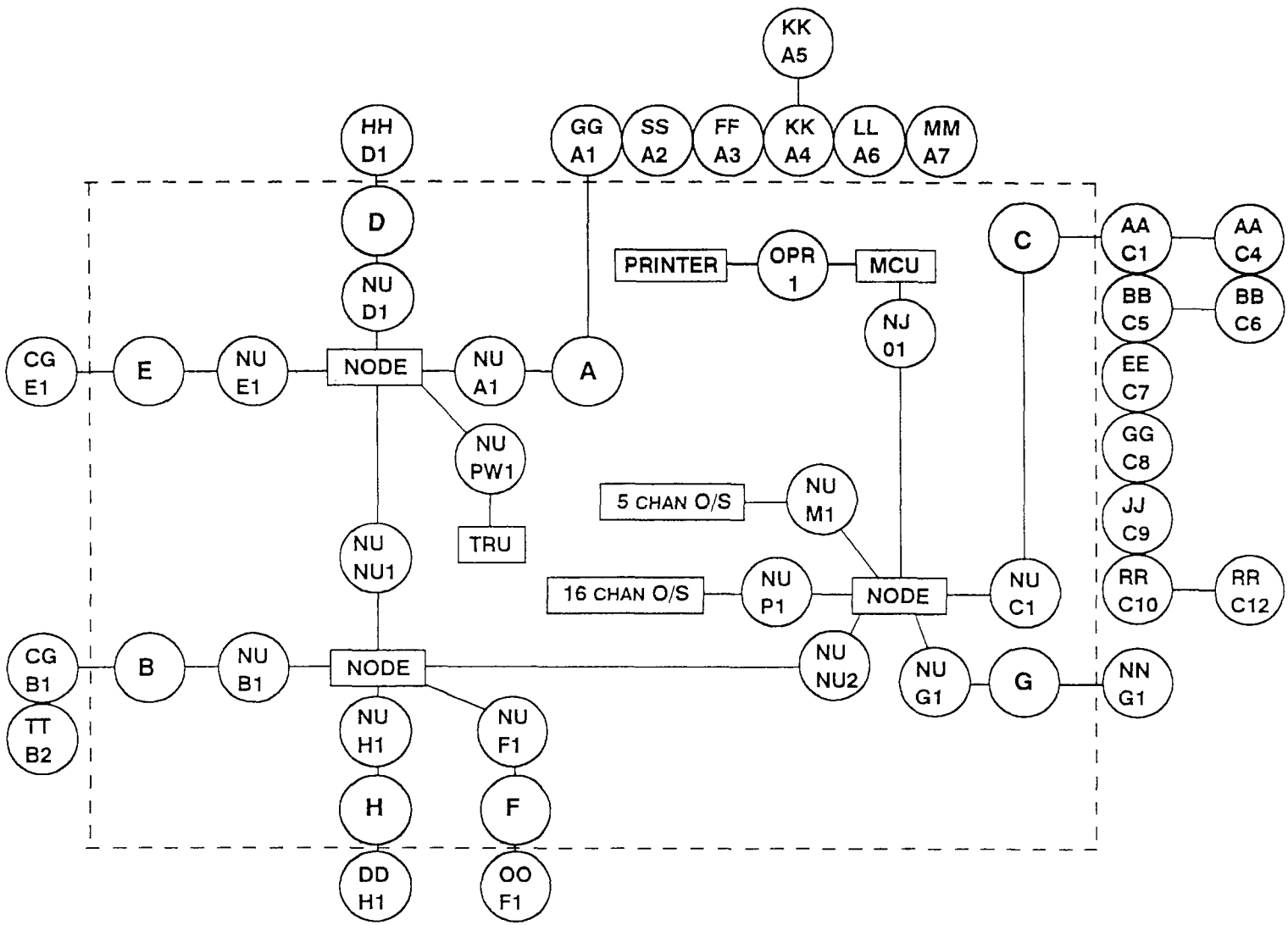
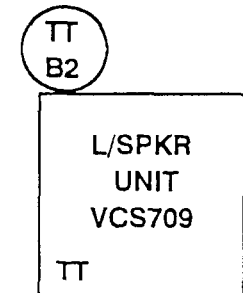
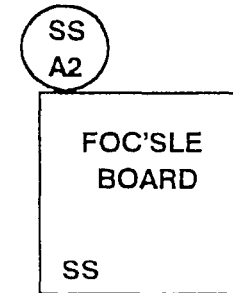
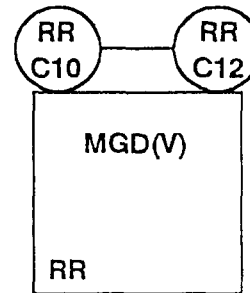
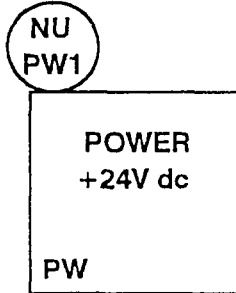
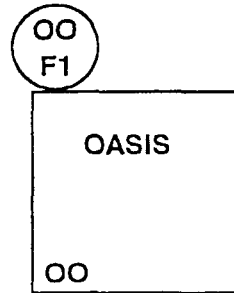
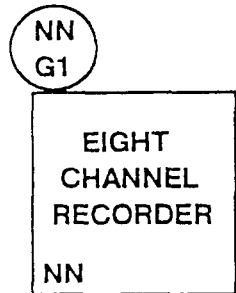
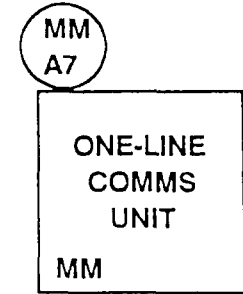
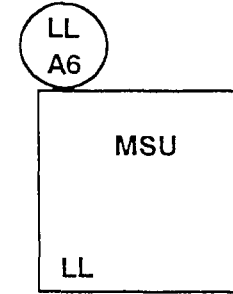
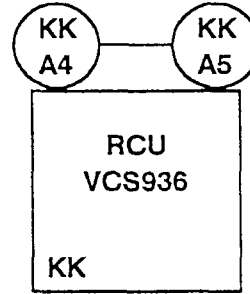
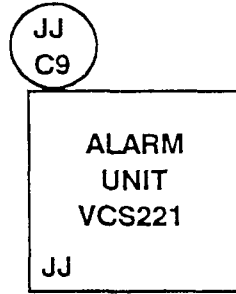
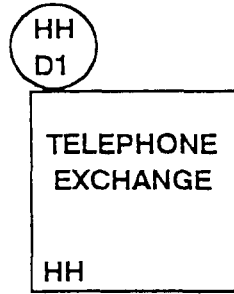
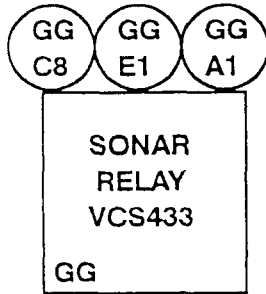
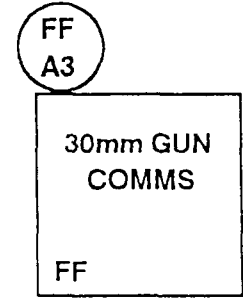
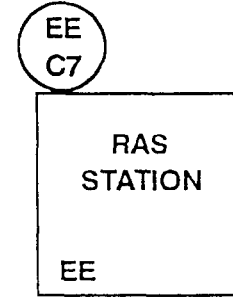
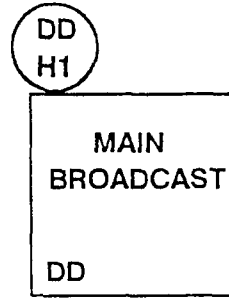
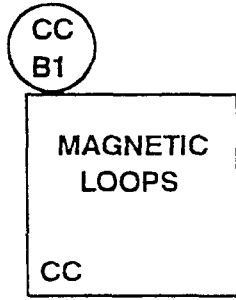
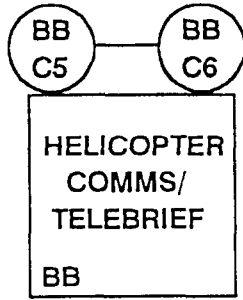
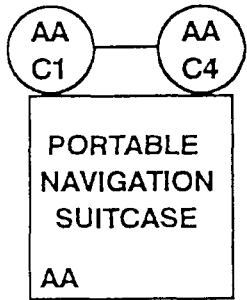

FIG. 9—RICE 10 SYSTEM INTERFACE DIAGRAM



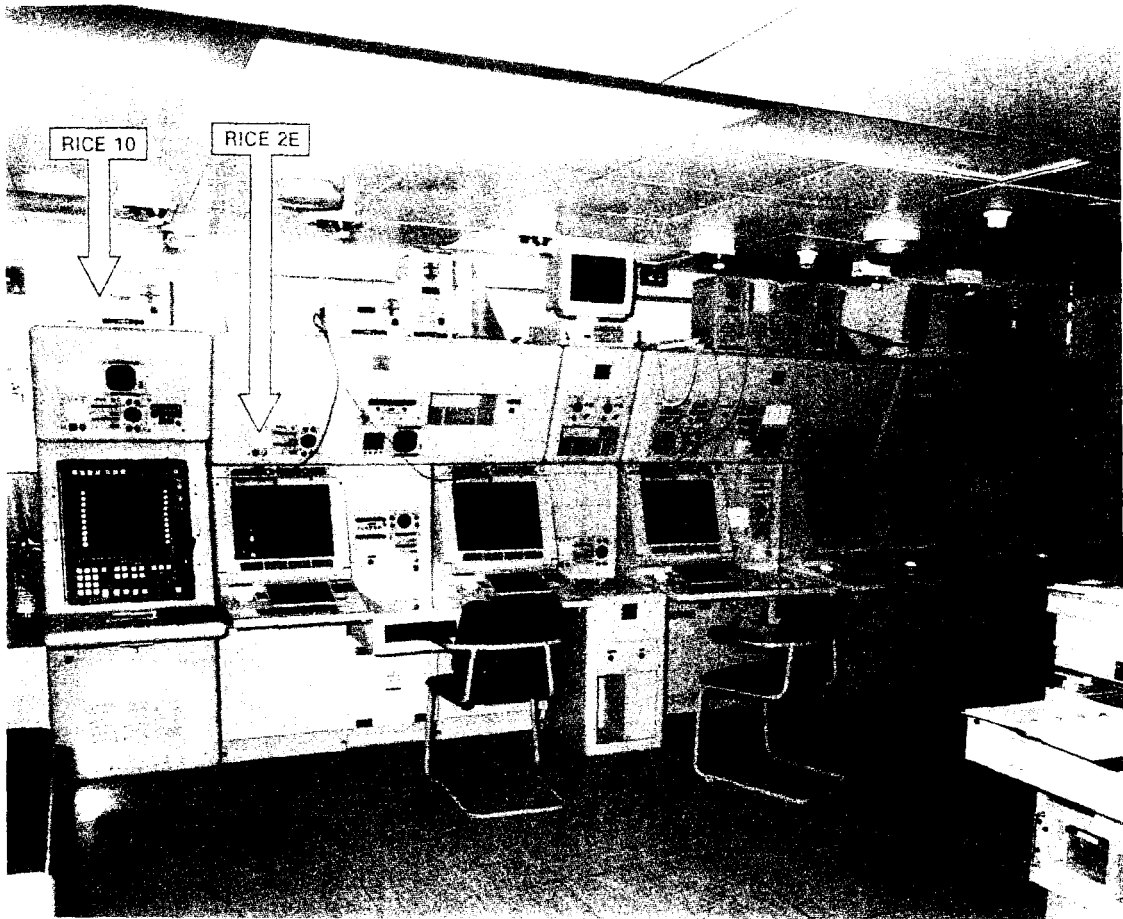

FIG. 10—RICE 10 INSTALLED ALONGSIDE RICE 2E AT THE TYPE 23 SDF

a node is to damage of another node or data connection. An ideal RICE 10 system topography is one that is truly multi-dimensional to provide a lower average number of inter-nodal connections between nodes.

The network symmetry has a direct bearing on the resilience of a damaged network to *blocking*. The more symmetric a network is, the higher the system tolerance to link or node damage. However, there may sometimes be a trade-off between network symmetry and the number of system data layers.

The vulnerability of a node to system damage is partially based on the probability of inter-nodal connections to that node being damaged. Generally, node-to-node cable lengths should be minimized to reduce the probability of damage. Therefore, an ideal system network will minimize the total system cable length.

### System reconfiguration

RICE 10 is the first internal communication system to be used by the Royal Navy that offers automatic and controlled system reconfiguration. System reconfiguration will be automatic following battle damage or may be controlled by an individual maintainer or system operator.

### *Battle damage*

System control data, data clock and voice information are distributed using the RICE 10 digital node network. Each network junction consists of a node connected to up to three different nodes. In the event of battle damage to a node

or inter-nodal data cable, the RICE 10 nodes will automatically re-establish a system master node and re-route data messages as necessary.

#### *Maintainer control*

The system communication facilities may be changed using the central control functions provided by the MCU. The MCU can re-configure a system communication schedule by loading a complete new system schedule from a connection to any RICE 10 node. In addition, individual outstation communication facilities may be adjusted from the MCU to re-configure what functions are available and at which physical outstation location.

#### *Operator control*

RICE-10 offers a *follow-me* facility whereby an operator may re-configure a 16 channel outstation to provide his own communication set. This reconfiguration capability requires the operator to enter a unique three digit code using the outstation numeric key-pad. Individual outstations may be protected from being re-configured by an operator if required.

### **Intelligibility testing**

An essential prerequisite of any voice communication system is that its intelligibility must meet a minimum specified requirement. Formal intelligibility testing provides an objective and repeatable method of demonstrating a system performance.

RICE-10 was independently tested by the DRA, Portsmouth West, using the Diagnostic Rhyme Test defined in the American National Standards Method for measuring the intelligibility of speech over communication systems, ANSI S3.2—1989. Using this test method, the listener is provided with a list of 96 word pairs. One of the words of each pair is presented via the headset and the listener decides which word has been heard, marking the list accordingly.

The numbers of errors are counted at the end of each word list and the overall average error is determined for all the listeners in the test. A correction for guessing is applied and the overall intelligibility score is calculated as a percentage.

For the test of RICE 10, the word lists were randomized in order to prevent any effects due to listener memorisation. Five talkers with different regional British accents, three male and two female, were selected to read the word lists. Five listeners were used at any one time for each of the 20 word lists used. Spectrally shaped white noise was added to the signal to simulate a talker in above-deck and operational room environments.

The intelligibility testing carried out by DRA Portsmouth on RICE 10 achieved Diagnostic Rhyme Test scores among 87% to 90% for all the tests. This compares favourably with the specified requirement of DEF STAN 00-25 which requires an intelligibility of at least 85%.

### **Reliability**

Since RICE 10 is to be used on a number of different platforms with different configurations, its reliability performance was specified in terms of the node and outstation reliability rather than an overall system or facility availability. A high reliability is essential for such equipment if support costs of a system are to be minimized.

#### *Equipment reliability*

The reliability requirement was specified as:

- Node reliability of 90% for a four month mission.
- Outstation reliability of 99% for a one month mission.



